

**Amherst Island Wind Energy
Project - Renewable Energy
Approval Amendment
Modification Report #4**



Prepared for:
Windlectric Inc.
2845 Bristol Circle
Oakville ON L9H 7H7

Prepared by:
Stantec Consulting Ltd.
1-70 Southgate Drive
Guelph ON N1G 4P5
T: 519-836-6050
F: 519-836-2493

File No. 160960595
May 2015

AMHERST ISLAND WIND ENERGY PROJECT - RENEWABLE ENERGY APPROVAL AMENDMENT MODIFICATION REPORT #4

Table of Contents

1.0	INTRODUCTION	1.1
1.1	BACKGROUND	1.1
1.2	SUMMARY AND RATIONALE FOR MINOR MODIFICATIONS.....	1.2
1.2.1	Change #1 – Technical Change	1.2
1.2.2	Change #2 – Project Design Change.....	1.2
1.2.3	Change #3 – Technical Change	1.3
2.0	RESULTS OF EFFECTS ASSESSMENT FOR THE PROJECT MODIFICATION.....	2.1
2.1	IMPACTS ON STUDIES/ REA REPORTS	2.1
2.1.1	Heritage Assessment	2.1
2.1.2	Protected Properties Assessment	2.2
2.1.3	Natural Heritage Assessment (NHA) and Environmental Impact Study (EIS)	2.3
2.1.4	Water Assessment and Water Body Report (WAWBR)	2.4
2.1.5	Stage II Archaeological Assessment.....	2.6
2.1.6	Noise Impact Assessment.....	2.6
2.1.7	Summary of Impacts/Changes to REA Reports and Studies.....	2.6
3.0	CONSULTATION.....	3.1
3.1	GENERAL STAKEHOLDER CONSULTATION	3.1
3.2	AGENCY CONSULTATION	3.1
3.3	MUNICIPAL CONSULTATION	3.2
3.4	ABORIGINAL COMMUNITY ENGAGEMENT	3.2
4.0	CLOSURE.....	4.1

LIST OF TABLES

Table 1: Summary of Impacts/Changes to REA Reports & Studies.....	2.8
---	-----

LIST OF APPENDICES

- Appendix A: Figures
- Appendix B: WAWBR Revised Figures and Tables
- Appendix C: Correspondence with MOECC
- Appendix D: Correspondence with MNRF
- Appendix E: Correspondence with MTCS
- Appendix F: Noise Assessment Report

AMHERST ISLAND WIND ENERGY PROJECT - RENEWABLE ENERGY APPROVAL AMENDMENT MODIFICATION REPORT #4

Introduction
May 2015

1.0 Introduction

1.1 BACKGROUND

Windlectric Inc. (the Proponent or Windlectric) submitted a Renewable Energy Approval (REA) Application on April 18, 2013 to develop, construct and operate the Amherst Island Wind Energy Project (the Project) within Loyalist Township (the Township) in the County of Lennox and Addington (the County) in eastern Ontario, in response to the Government of Ontario's initiative to promote the development of renewable electricity in the province. Since submission of the REA, Windlectric submitted three REA amendment modification reports (dated June 2014, July 2014, and March 2015) as a result of reviewing design features of the layout, feedback received from the Ministry of the Environment and Climate Change (MOECC), and to clarify that the temporary batch plant is part of the REA application.

The basic components of the proposed Project, as set out in the REA application (submitted April 18, 2013), include up to 36 Siemens wind turbines, with a total installed nameplate capacity of approximately 56 - 75 MW, depending on final selection of the model of the wind turbine most appropriate to the proposed Project.

The proposed Project will also include a 34.5 kilovolt (kV) underground and/or overhead electrical power line collector system, fibre optic data lines from each turbine and/or wireless technology for the communication of data, a transmission line, truck turnaround areas, a submarine cable, an operations and maintenance building, permanent dock, a substation, a switching station, an un-serviced storage shed, one connection point to the existing electrical system, cable vault areas, meteorological tower(s) (met tower(s)), access road(s) to the met tower site(s), and turbine access roads with culvert installations, as required, at associated watercourse crossings.

Temporary components during construction may include staging areas for the turbines, access roads, met tower(s), collector lines and transmission line as well as crane paths, a temporary dock, site office(s), batch plant, central staging areas, and associated watercourse crossings. The electrical power line collector system would transport the electricity generated from each turbine to the substation, along the submarine cable to the mainland and then to a switching station located near to an existing Hydro One Networks Inc. (HONI) 115 kV transmission line.

AMHERST ISLAND WIND ENERGY PROJECT - RENEWABLE ENERGY APPROVAL AMENDMENT MODIFICATION REPORT #4

Introduction
May 2015

This report and its attachments provide information regarding the minor modifications. Based on the information set out below, the minor modifications are Technical and Project Design Changes pursuant to the classification system outlined in the Ministry of the Environment's *Technical Guide to Renewable Energy Approvals* (October, 2013). As such, this document has been prepared to address the requirements of Chapter 10 "Making Changes to REA Projects" of the Technical Guide.

1.2 SUMMARY AND RATIONALE FOR MINOR MODIFICATIONS

1.2.1 Change #1 – Technical Change

This modification involves changing the Project's turbines from a combination of 21 Siemens SWT-2.3-113 2.300 MW and 15 Siemens SWT-2.3-113 2.221 MW to a combination of 12 Siemens SWT-3.2-113 2.942 MW and 15 Siemens SWT-3.2-113 2.772 MW, and thereby reducing the number of turbines from up to 36 to 27, of which 26 will be installed. This modification is proposed as a result of reviewing design features of the project layout in an effort to reduce the Project's footprint.

The new turbines would be physically identical to the previous proposed model, specifically with a hub height of 99.5 m and rotor diameter of 113 m. The modification will decrease the Project Location area by reducing the number of turbine sites from up to 36 to 27. All of these 27 turbine sites are in previously studied and proposed locations.

The locations of the removed and remaining turbine sites are presented in the attached figures (Appendix A) and discussed in the following sections.

The construction and installation activities for the turbines will be completed in the same manner as the turbines described in the Construction Plan Report, submitted as part of the REA Application.

1.2.2 Change #2 – Project Design Change

This modification would involve rerouting the collection system to avoid the Village of Stella. In doing so, this modification would remove a significant portion of the collector line that would otherwise run along Front Road from Turbine S30 entrance west and along Stella Forty Foot Rd south. The modification would also remove approximately 4 km of road allowance trenching (including through Stella). The modification would require a new collector line from Turbine S13 to South Shore Rd. and west to Turbine S14 entrance, which would consist of approximately 1 km in municipal road allowance and 700 m of in pasture field. This modification is proposed as a result of reviewing design features of the project layout in an effort to reduce the Project's footprint and to minimize any potential impact to the Village of Stella.

The modification will decrease the Project Location size by resulting in a net reduction of approximately 2 km of collection system trenching.

AMHERST ISLAND WIND ENERGY PROJECT - RENEWABLE ENERGY APPROVAL AMENDMENT MODIFICATION REPORT #4

Introduction
May 2015

The revised location for the collector line is presented in the attached figures (Appendix A) and discussed in the sections below.

The construction and installation activities for the collector line will be completed in the same manner as the collector line which is described in the Construction Plan Report, submitted as part of the REA Application.

1.2.3 Change #3 – Technical Change

This modification would involve the addition of an underground collector line along a previously proposed access road between Turbines S16/S23 and S35. The collector line has been incorporated into the design of the access road between Turbines S16/23 and S35. This modification is proposed as a result of reviewing design features of the project layout in an effort to reduce the Project footprint.

The modification will decrease the Project Location size by eliminating the need to install a second collection circuit trench on approximately 3 km of 2nd Concession Road.

The location for the collector line is presented in the attached figures (Appendix A) and discussed in the following sections below.

The construction and installation activities for the collector line will be completed in the same manner described in the Construction Plan Report, submitted as part of the REA Application.

AMHERST ISLAND WIND ENERGY PROJECT - RENEWABLE ENERGY APPROVAL AMENDMENT MODIFICATION REPORT #4

Results of Effects Assessment for the Project Modification
May 2015

2.0 Results of Effects Assessment for the Project Modification

O. Reg. 359/09 requires that any adverse environmental effects that may result from construction, installation, operation and maintenance activities be described. The term “environment” in O. Reg. 359/09 has the same meaning as in the *Environmental Protection Act*, and includes the natural, physical, cultural, and socio-economic environment.

A screening to identify any new environmental effects that would require additional mitigation or monitoring measures beyond those outlined in the REA documents as a result of the proposed modifications to the Project was completed.

In summary, none of the three proposed minor modifications described above will result in increased negative environmental effects that will or are likely to occur beyond those originally identified, documented and consulted on during the REA process for the original project.

2.1 IMPACTS ON STUDIES/ REA REPORTS

The REA reports require a material change to the content as a result of the modifications. A summary of the sections and figures to be amended in each REA report and the applicable text change is provided in the table below.

2.1.1 Heritage Assessment

The Project Location associated with Change #1 and 3 was previously assessed as part of the Heritage Assessment that was submitted as part of the original REA Application and was subsequently accepted by the Ministry of Tourism, Culture and Sport (MTCS) in their Confirmation Letter. As such, no additional Heritage Assessment was required for Change #1, and 3.

Additional assessment to determine the presence of potential heritage resources was necessary for Change #2.

Impact assessments contained within the Heritage Assessment were determined to remain valid for all properties excluding BHR 3, 7, 18, 20, and 21. While in some cases the assessment addressed turbines which are no longer proposed or residences that no longer exist (i.e. BHR 24, 5330 Bath Road), it is only in the case of 2450 South Shore Road (BHR 3) where new infrastructure is proposed near the location that had not been previously assessed. Therefore, an impact assessment was undertaken in addition to the assessment completed as part of the Heritage Assessment.

It was determined that, given the vicinity of the resource to the newly proposed collector lines positioned underground within the municipal right of way, there will be no direct Project related

AMHERST ISLAND WIND ENERGY PROJECT - RENEWABLE ENERGY APPROVAL AMENDMENT MODIFICATION REPORT #4

Results of Effects Assessment for the Project Modification
May 2015

negative impacts expected. However, there is the potential for indirect impacts resulting from construction vibrations. With the identification of a new potential indirect impact resulting from proposed Project modifications, mitigation measures have been developed (as described below) so that no negative impacts are expected.

The potential for indirect impacts resulting from construction vibrations was identified during an impact assessment of 2450 South Shore Road (BHR 3). The impact was similar to that identified for BHRs 4, 5, 6, 19, 20, and 21 in the 2013 Heritage Assessment. Given the similarity in distance anticipated between the construction area and the resource, it was determined that mitigation recommendations contained within the Report would be appropriate. Therefore, Project activities should first be avoided within a 50 metre bufferzone surrounding the residence if possible. Where this activity cannot be avoided, maximum acceptable vibration levels should be determined and monitored. If these levels are exceeded, all Project activities taking place within the 50 metre bufferzone should cease until a solution can be determined.

It was determined that the recommendations contained within the Heritage Assessment should be modified to reflect areas where additional assessment was undertaken as well as those where recommendations are no longer valid. See Appendix E for correspondence with the MTCS, including the additional assessment undertaken and associated recommendations.

2.1.2 Protected Properties Assessment

The Project Location associated with Change #1 and 3 was previously assessed as part of the Protected Properties Assessment that was submitted as part of the original REA Application and was subsequently accepted by the MTCS in their Confirmation Letter. As such, no additional Protected Properties Assessment was required for Change #1, and 3. Additional assessment to determine the relationship between previously identified protected properties and Change #2 is necessary along South Shore Road in between Turbines S13 and S14.

Upon review of the Protected Properties Assessment, it was determined that no additional assessment is required. The recommendations contained within the Report address potential impacts that are no longer anticipated as a result of the removal of Project infrastructure for Change #2. The recommendations as they exist in the 2013 Report address all designated properties at the time of the writing of the Report and not just those situated at, or abutting, the Project Location. As such, the recommendations remain valid and are considered to satisfy requirements made under *Ontario Regulation 359/09*.

Based on these findings, it was determined that the analysis, assessment, and recommendations of the Protected Properties Assessment remain unchanged as a result of the proposed project modification.

AMHERST ISLAND WIND ENERGY PROJECT - RENEWABLE ENERGY APPROVAL AMENDMENT MODIFICATION REPORT #4

Results of Effects Assessment for the Project Modification
May 2015

2.1.3 Natural Heritage Assessment (NHA) and Environmental Impact Study (EIS)

The NHA/EIS (included in the REA Application) identified natural features within the Project Location and the associated 120 m Zone of Investigation around the limits of the Project Location

A technical review was conducted to determine if the modifications result in: a change to the identification of natural features within 120 m of the new Project Location; a change to the assessment of impacts and mitigation measures; and the overall assessment of changes to the NHA/EIS.

The Project Location associated with Change #1 and 3 was previously assessed as part of the NHA/EIS that was submitted as part of the original REA Application and was subsequently accepted by the Ministry of Natural Resources and Forestry (MNRF) in their Confirmation Letter dated December 14, 2012. As such, no additional NHA/EIS was required for Change #1, and 3. Change #2 does not result in discussion of any natural features being removed from the NHA/EIS. In addition, the modification results in only one new feature being within 120 m of the Project Location – namely, a woodland feature is located within 120 m of the new underground collector line running along South Shore Road. This feature was identified in the mapping in the December 2012 NHA/EIS but was not located within the Zone of Investigation at that time.

Specifically, for Change #2, site investigations had previously been completed at the location along South Shore Road and up to S13. As a result, additional site visits were not required to determine the status and boundary of natural features. Natural features that occur in or within 120 m of the revised Project Location are already identified on the maps provided within the NHA/EIS.

As mentioned above, other candidate significant natural heritage features that occur within 120 m of the new section of underground collector line were previously identified in the December 2012 NHA/EIS. The evaluation of significance of these features in the December 2012 NHA does not change as a result of the Project modifications.

Minor changes to the EIS are required to address the new woodland feature 22, changes in Project distance to SSB-4 and temporary removal of habitat in RWA-6 and OCB-7. Existing mitigation, monitoring and contingency measures remain applicable to ensure there will be no residual negative effects associated with such temporary removal.

Overall, the Project modification will result in minor changes to the NHA/EIS, including addition of significant woodland feature 22 and revised distance calculations to significant wildlife habitat feature SSB4 and temporary removal of habitat in RWA-6 and OCB-7. No changes to impacts, mitigation, monitoring or contingency of impacts to woodlands are required. No additional potential impacts are anticipated to feature SSB4.

AMHERST ISLAND WIND ENERGY PROJECT - RENEWABLE ENERGY APPROVAL AMENDMENT MODIFICATION REPORT #4

Results of Effects Assessment for the Project Modification
May 2015

It was concluded that overall, the modifications will not result in new negative effects not previously identified and mitigated in the NHA/EIS.

Further, the proposed modifications do not require any additions to the Environmental Effects Monitoring Plan (EEMP) as submitted with the REA Application.

2.1.4 Water Assessment and Water Body Report (WAWBR)

The WAWBR (included in the REA application) identified water bodies within the Project Location and the associated 120 m Zone of Investigation around the limits of the Project Location.

A technical review was conducted to determine if the modifications result in: a change to the identification of water bodies within 120 m of the new Project Location; a change to the assessment of impacts and mitigation measures; and the overall assessment of changes to the Water Assessment and Water Body Report (WAWBR).

The Project Location associated with Change #1 and 3 was previously assessed as part of the WAWBR that was submitted as part of the original REA application. As such, no additional assessment was required for Change #1 and 3. Change #2 results in the removal of three waterbodies from the WAWBR. In addition, Change #2 results in no new features being within 120 m of the Project Location. A water feature is located within 120 m of the new underground collector line running along South Shore Road. This feature was identified in the mapping in the December 2012 WAWBR and was located within the Zone of Investigation at that time.

Specifically, for Change #2, site investigations had previously been completed at the location along South Shore Road and up to Turbine S13. As a result, additional site visits were not required to determine the status and boundary of water bodies. Water bodies that occur in or within 120 m of the revised Project Location are already identified on the maps provided within the WAWBR.

As mentioned above, other waterbodies that occur within 120 m of the new section of underground collector line were previously identified in the December 2012 WAWBR. The evaluation of water bodies in the December 2012 WAWBR does not change as a result of the Project modifications.

No new water body features were identified as a result of the new Project Location (aside from those previously assessed).

Standard mitigation measures previously identified in the WAWBR still apply for the new collector line locations.

The modified Project Location will result in minor changes to the following tables in the WAWBR:

AMHERST ISLAND WIND ENERGY PROJECT - RENEWABLE ENERGY APPROVAL AMENDMENT MODIFICATION REPORT #4

Results of Effects Assessment for the Project Modification
May 2015

- **Table 3.1** Summary of mapped watercourses/waterbodies (LIO) in the Zone of Investigation and criteria for REA water bodies
- **Table 3.2** Summary Table of Water Bodies and Project Components
- **Table 4.2** Summary of Water Bodies Within the 120 m Zone of Investigation, and
- **Table 4.3** Water Bodies that provide fish habitat where in-water work is required.

The revised tables are included in Appendix B. The sections below provide a summary of the changes and the resulting alterations to the WAWBR as a result of Changes #1 through #3.

It was concluded that the modifications will not result in potential effects not previously identified and mitigated in the WAWBR.

Change #1

This modification will result in a reduction of two crossings of waterbodies by collector lines within the Western Drainage Subwatershed:

- Waterbodies at Station 6 and Station 25 will not be crossed by collector lines due the removal of Turbines S17 and S10 from the Project layout.

Change #2

This modification will result in no modified waterbody crossings by collector lines within the Southern, Western or Eastern Drainage Subwatersheds.

This modification will result in a reduction of three crossings of waterbodies by underground collector lines in the Northern Drainage subwatershed:

- Waterbodies at Stations 55, 57 and 21 will not be crossed by collector lines due to the rerouting of the collection system to avoid the Village of Stella.

Change #3

This modification will result in no modified waterbody crossings by collector lines in the Project Location.

AMHERST ISLAND WIND ENERGY PROJECT - RENEWABLE ENERGY APPROVAL AMENDMENT MODIFICATION REPORT #4

Results of Effects Assessment for the Project Modification
May 2015

2.1.5 Stage II Archaeological Assessment

The Project Location associated with Change #1 and 3 was previously assessed as part of the Stage II Archaeological Assessment that was submitted as part of the original REA Application and was subsequently accepted by the MTCS in their Confirmation Letter dated March 13, 2013. As such, no additional Stage II Archaeological Assessment was required for Change #1 and 3.

The Project Location associated with Change #2 was not previously assessed as part of the Stage II Archaeological Assessment that was submitted as part of the original REA Application. As such, additional Stage II Archaeological Assessment was completed for Change #2. It was concluded that the Stage II Archaeological Assessment resulted in the identification of no archaeological resources, and therefore it is recommended that no further archaeological assessment of the study area is required.

2.1.6 Noise Impact Assessment

The Noise Assessment Report was updated to consider the reduction in number of turbine locations, updated sound levels for the two different turbine models and removal of those receptors no longer within 1,500 m of a turbine location. The predicted sound level at all receptors; participating and non-participating, was calculated to be lower as a result of the modification. See Appendix F for the revised Noise Assessment Report. Additionally, the Amherst Island Public School is now more than 1,500 m from the nearest turbine and is therefore no longer included in the noise assessment report as required by the guidelines. However, the sound level results for the school are provided below.

Noise Receptor ID	Description	UTM NAD 83, Zone 18		Nearest Source Distance [m]			Sound Pressure [dBA]						Limit
				WTG		Sub- station	POR at 4.5 m			POR at 1.5 within 30 m			
		X	Y	Distance	ID	Distance	Substation	WTGs	Total	Substation	WTGs	Total	
R557	School	363796	4892015	1756	S31	1060	32.0	31.6	34.8	29.9	30.2	33.0	40.0

2.1.7 Summary of Impacts/Changes to REA Reports and Studies

The proposed modifications will not result in an increase in the negative environmental effects that will or are likely to occur beyond those that were identified, documented and consulted on during the REA process for the original layout. In fact, the proposed modifications will reduce potential effects associated with the Project, especially given the substantial reduction in the number of turbines and the net reduction in length of and temporary disturbance associated with the collector lines.

AMHERST ISLAND WIND ENERGY PROJECT - RENEWABLE ENERGY APPROVAL AMENDMENT MODIFICATION REPORT #4

Results of Effects Assessment for the Project Modification
May 2015

The following table provides a list of the REA reports and studies that were reviewed by the MOECC, and notes whether changes to the reports are required due to the modifications proposed. As well, an outline of the specific changes or the justification for no change being required is provided. Any changes to the reports have been addressed by issuance of this Modification Report and its appendices.

AMHERST ISLAND WIND ENERGY PROJECT - RENEWABLE ENERGY APPROVAL AMENDMENT MODIFICATION REPORT #4

Results of Effects Assessment for the Project Modification
May 2015

Table 1: Summary of Impacts/Changes to REA Reports & Studies

REA Reports & Studies	Change (Yes/No)	Figure No.	Discussion of change / Justification for 'no' change
REA REPORTS			
Project Description Report	Yes	1.0, 1.2, 2.0, 2.2 3.0, 3.2 4.0, 4.2. 4.4, 4.4. 4.5 5, 6	<p>Figures to be updated to remove those turbine locations which will not be constructed and the associated infrastructure, the new collector line between Turbines S16/S23 and S35; and the new location of the collector line from Turbine S13 South Shore Rd. and west to Turbine S14 entrance. (Change#1, 2, and 3)</p> <p>Section 1.1: amend text to the reduced number of turbine sites (27) and updated combination of turbines.</p> <p>Section 3.1: amend text to the revised 27 turbine sites and combination of Siemens turbines.</p>
Construction Plan Report	Yes	1.0, 1.2, 2.0, 2.2 3.0, 3.2 4.0, 4.2. 4.4, 4.4. 4.5	<p>Figures to be updated to remove those turbine locations which will not be constructed and the associated infrastructure, the new collector line between Turbines S16/S23 and S35; and the new location of the collector line from Turbine S13 South Shore Rd. and west to Turbine S14 entrance. (Change#1, 2, and 3)</p> <p>Section 1.1: amend text to the reduced number of turbine sites (27) and updated combination of turbines.</p>
Design & Operations Report	Yes	1.0, 1.2, 2.0, 2.2 3.0, 3.2 4.0, 4.2. 4.4, 4.4. 4.5	<p>Figures to be updated to remove those turbine locations which will not be constructed and the associated infrastructure, the new collector line between Turbines S16/S23 and S35; and the new location of the collector line from Turbine S13 South Shore Rd. and west to Turbine S14 entrance. (Change#1, 2, and 3)</p> <p>Section 1.1: amend text to the reduced number of turbine sites (27) and updated combination of turbines.</p>
Decommissioning Plan Report	Yes	n/a	<p>There are no figures within the Decommissioning Plan Report; therefore no changes required.</p> <p>Section 1.1: amend text to the reduced number of turbine sites (27) and updated combination of turbines.</p>

AMHERST ISLAND WIND ENERGY PROJECT - RENEWABLE ENERGY APPROVAL AMENDMENT MODIFICATION REPORT #4

Results of Effects Assessment for the Project Modification
May 2015

Table 1: Summary of Impacts/Changes to REA Reports & Studies

REA Reports & Studies	Change (Yes/No)	Figure No.	Discussion of change / Justification for 'no' change
Consultation Report	Yes	n/a	Consultation with government representatives have been undertaken for the proposed modifications to the Project, and the mechanism to update the project documents is described in Section 3 of this Modification Document.
ADDITIONAL REPORTS			
Natural Heritage Assessment Report	Yes	1A, 1B 2.0, , 2.2, 2.3, 2.4, 2.5 3.0, , 3.2, 3.3, 3.4, 2.5 4.0, , 4.2, 4.3, 4.4, 4.5 5.0, , 5.2, 5.3, 5.4, 5.5 6.0, , 6.2, 6.3, 6.4, 6.5	<p>Figures to be updated to remove those turbine locations which will not be constructed and the associated infrastructure, the new collector line between Turbines S16/S23 and S35; and the new location of the collector line from Turbine S13 South Shore Rd. and west to Turbine S14 entrance. (Change#1, 2, and 3)</p> <p>Executive Summary and Section 1.1: amend text to the reduced number of turbine sites (27) and updated combination of Siemens turbines.</p> <p>Table 3.9: update to include Woodland 22 and the distance calculation to candidate wildlife habitat feature SSB4.</p> <p>Section 4.2.2: amend text to indicate 16 significant woodlands occur within 120 m of the Project Location, which includes the new woodland feature 22.</p> <p>Table 4.8: update to include Significant Woodland 22 and the distance calculation to significant wildlife habitat feature SSB4.</p> <p>Section 5.3.1: amend text to indicate 16 significant woodlands occur within 120 m of the Project Location, which includes the new woodland feature 22.</p> <p>Section 5.3.3.9: amend text to indicate the closest Project component is the underground collector line that is 1 m away from the SSB4 in a public right of way.</p> <p>Table 7B: update with woodland feature 22.</p> <p>Table 10B: updated o include the evaluation of woodland feature 22.</p>

AMHERST ISLAND WIND ENERGY PROJECT - RENEWABLE ENERGY APPROVAL AMENDMENT MODIFICATION REPORT #4

Results of Effects Assessment for the Project Modification
May 2015

Table 1: Summary of Impacts/Changes to REA Reports & Studies

REA Reports & Studies	Change (Yes/No)	Figure No.	Discussion of change / Justification for 'no' change
			<p>Table 13B: update to include the portion of underground collector line in RWA-6 and OCB-7, between S13 and South Shore Road, in the amount of habitat that will be removed for short-term duration.</p> <p>Table 14B: update to include woodland feature 22 in the list of significant woodlands.</p>
Water Assessment Report	Yes	1, 2 (1, 2 and 3 of 4) 5 (1,2 and 3 of 4)	<p>Figures to be updated to remove those turbine locations which will not be constructed and the associated infrastructure, the new collector line between Turbines S16/S23 and S35; and the new location of the collector line from Turbine S13 South Shore Rd. and west to Turbine S14 entrance. (Change#1, 2, and 3)</p> <p>Section 1.1: amend text to the reduced number of turbine sites (27) and updated combination of turbines.</p> <p>Table 3.1 Summary of mapped watercourses/waterbodies (LIO) in the Zone of Investigation and criteria for REA water bodies (See Appendix B of this report)</p> <p>Table 3.2 Summary Table of Water Bodies and Project Components (See Appendix B of this report)</p> <p>Table 4.2 Summary of Water Bodies Within the 120 m Zone of Investigation (See Appendix B of this report)</p> <p>Table 4.3 Water Bodies that provide fish habitat where in-water work is required. (See Appendix B of this report)</p>
Stage 1 Archaeological Assessment	Yes	2, 5, 6, 7, 8, 10	<p>Figures to be updated to remove those turbine locations which will not be constructed and the associated infrastructure, the new collector line between Turbines S16/S23 and S35; and the new location of the collector line from Turbine S13 South Shore Rd. and west to Turbine S14 entrance. (Change#1, 2, and 3)</p> <p>Section 1.1: amend text to the reduced number of turbine sites (27) and updated combination of turbines.</p>

AMHERST ISLAND WIND ENERGY PROJECT - RENEWABLE ENERGY APPROVAL AMENDMENT MODIFICATION REPORT #4

Results of Effects Assessment for the Project Modification
May 2015

Table 1: Summary of Impacts/Changes to REA Reports & Studies

REA Reports & Studies	Change (Yes/No)	Figure No.	Discussion of change / Justification for 'no' change
Stage 2 Archaeological Assessment	Yes	2, 4, 5, 6, 7,	<p>Figures to be updated to remove those turbine locations which will not be constructed and the associated infrastructure, the new collector line between Turbines S16/S23 and S35; and the new location of the collector line from Turbine S13 South Shore Rd. and west to Turbine S14 entrance. (Change#1, 2, and 3)</p> <p>Section 1.1: amend text to the reduced number of turbine sites (27) and updated combination of turbines.</p>
Underwater Archaeological Report	Yes	1	<p>Figures to be updated to remove those turbine locations which will not be constructed and the associated infrastructure, the new collector line between Turbines S16/S23 and S35; and the new location of the collector line from Turbine S13 South Shore Rd. and west to Turbine S14 entrance. (Change#1, 2, and 3)</p> <p>Section 2.1.1: amend text to the reduced number of turbine sites (27) and updated combination of turbines.</p>
Heritage Assessment Report	Yes	2, 3, 4, 5, 6, 7, 8, 9,11 12	<p>Figures to be updated to remove those turbine locations which will not be constructed and the associated infrastructure, the new collector line between Turbines S16/S23 and S35; and the new location of the collector line from Turbine S13 South Shore Rd. and west to Turbine S14 entrance. (Change#1, 2, and 3)</p> <p>Section 1.3: amend text to the reduced number of turbine sites (27) and updated combination of turbines.</p>
Protected Properties Assessment	Yes	3, 5, 6, 8, 10, 11	<p>Figures to be updated to remove those turbine locations which will not be constructed and the associated infrastructure, the new collector line between T16/T23 and T35; and the new location of the collection corridor from S13 south shore Rd. and west to S14 entrance. (Change#1, 2, and 3)</p> <p>Section 1.1: amend text to the reduced number of turbine sites (27) and updated combination of Siemens turbines.</p>

AMHERST ISLAND WIND ENERGY PROJECT - RENEWABLE ENERGY APPROVAL AMENDMENT MODIFICATION REPORT #4

Results of Effects Assessment for the Project Modification
May 2015

Table 1: Summary of Impacts/Changes to REA Reports & Studies

REA Reports & Studies	Change (Yes/No)	Figure No.	Discussion of change / Justification for 'no' change
Wind Turbine Specifications Report	Yes	n/a	Section 1.1: amend text to the reduced number of turbine sites (27) and updated combination of Siemens turbines. Section 2.1: amend text to the updated combination of Siemens turbines. Table 2.1 and 2.3: update to include specifications of the updated turbines.
Noise Assessment Report (Appended to the Design and Operations Report)	Yes	Yes	Revised assessment and figures to remove those turbine locations which will not be constructed.
Property Line Setback Assessment	No	4	Remove Figure 4 Attachment B: Property Line assessment Summary Table – remove reference to Turbine S15.

AMHERST ISLAND WIND ENERGY PROJECT - RENEWABLE ENERGY APPROVAL AMENDMENT MODIFICATION REPORT #4

Consultation
May 2015

3.0 Consultation

Consultation regarding the proposed modification was undertaken with the MOECC, MNRF, MTCS, municipalities, stakeholders and local Aboriginal communities. Details are provided in the subsequent sections.

3.1 GENERAL STAKEHOLDER CONSULTATION

Windlectric will provide notification to stakeholders included on the Project distribution list regarding the proposed modification and application to the MOECC for an amendment to the Project's REA application. A Notice of Proposed Change to a Renewable Energy Project will be distributed, and will provide an overview of the proposed change, notification that a Modification Report to amend the Project's REA application has been submitted to the MOECC for review, information regarding availability of the Modification Report on the Project website.

The Notice and Modification Report will be posted on the Project website, to ensure the community is adequately informed of the proposed change. The Notice will be mailed to all Project stakeholders, including agencies, municipalities, Aboriginal communities, and community members that are on the Project distribution list. The Notice will also be published on at least two separate days within newspapers with general circulation in the Project area.

3.2 AGENCY CONSULTATION

- Consultation regarding the proposed modifications was undertaken with the MOECC via this Modification Document and as per a letter submitted to the MOECC dated May 1, 2015 (Appendix C).
- The Notice of Project Change has been provided to the MOECC and in a form agreed to by the Director of the Environmental Approvals Branch.
- The MNRF was advised of the proposed modifications through two letter addendums to the NHA/EIS (Appendix D). Consultation with the MNRF regarding changes to the NHA/EIS included obtaining written confirmation (Appendix D) that the MNRF is satisfied that the NHA requirements of O. Reg. 359/09 have been met.
- The MTCS was advised of the proposed modifications through letter addendums to the Heritage Assessment, Protected Properties Assessment and Stage 2 Archaeological Assessment (Appendix E). Consultation with the MTCS regarding changes to these assessments included obtaining written confirmation (Appendix E) that the MTCS is satisfied that the assessments met the requirements of O. Reg. 359/09.

AMHERST ISLAND WIND ENERGY PROJECT - RENEWABLE ENERGY APPROVAL AMENDMENT MODIFICATION REPORT #4

Consultation
May 2015

3.3 MUNICIPAL CONSULTATION

A hard and/or soft copy of this Modification Document will be provided to:

- Loyalist Township
- County of Lennox & Addington

3.4 ABORIGINAL COMMUNITY ENGAGEMENT

A hard and/or soft copy of this Modification Document will be provided to:

- Mississaugas of Scugog Island First Nation
- Curve Lake First Nation – Mississaugas of Mud Lake Curve Lake
- Hiawatha First Nation – Mississaugas of Rice Lake
- Alderville First Nation – Mississaugas of Aderville
- Kawartha Nishnawbe First Nation
- Mohawks of the Bay of Quinte – Tyendinaga Mohawks Territory
- Williams Treaty First Nations

AMHERST ISLAND WIND ENERGY PROJECT - RENEWABLE ENERGY APPROVAL AMENDMENT MODIFICATION REPORT #4

Closure
May 2015

4.0 Closure

The proposed modifications have been adequately assessed in accordance with O. Reg. 359/09 and the MOECC's Technical Guide. It has been determined that the modifications would not result in new negative environmental effects or associated mitigation measures beyond those identified as part of the original REA Application submitted for the Project.

This report has been prepared by Stantec for the sole use of Windlectric, and may not be used by any third party without the express written consent of Windlectric. The data presented in this report are in accordance with Stantec's understanding of the Project as it was presented at the time of reporting.

Prepared by 
(signature)

Kerrie Skillen, Project Manager

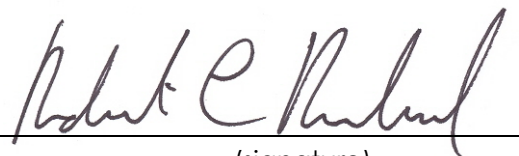
Reviewed by 
(signature)

Rob Rowland, Senior Project Manager

Appendix A:
Figures

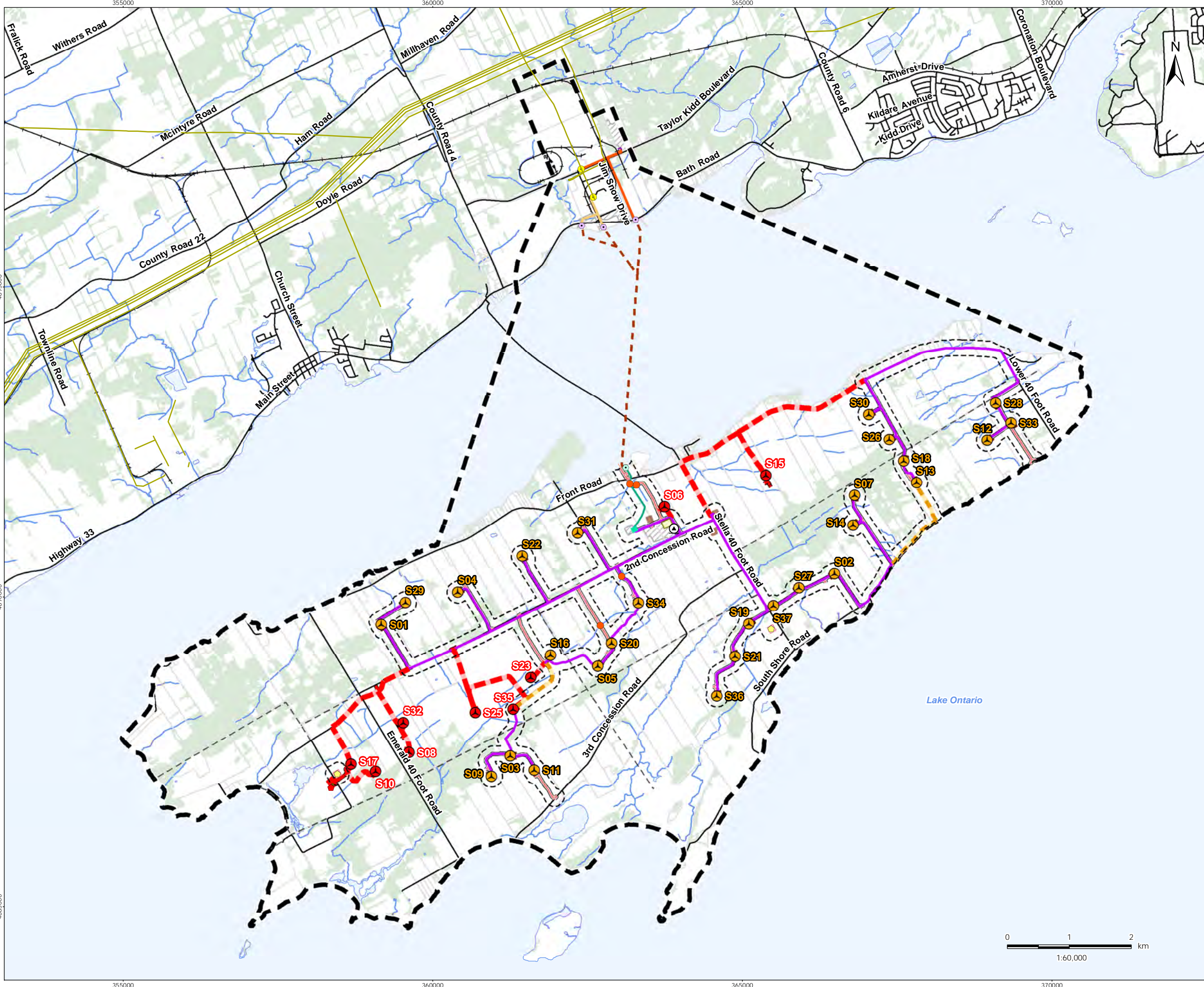

- Legend**
- Study Area
 - 120m Zone of Investigation
 - Project Components**
 - Turbine (No Changes Proposed)
 - Turbine (Removed)
 - Met Tower - Potential Location (No Changes Proposed)
 - Met Tower - Potential Location (Removed)
 - Access Road (No Changes Proposed)
 - Access Road (Removed)
 - Collector Line (No Changes Proposed)
 - Collector Line (New)
 - Collector Line (Removed)
 - Submarine Cable Path
 - Laydown Area and Crane Pad (No Changes Proposed)
 - Laydown Area and Crane Pad (Removed)
 - Operation and Maintenance Building (Potential Location)
 - Turbine Blade Tip (No Changes Proposed)
 - Turbine Blade Tip (Removed)
 - Substation (Potential Location)
 - Potential Culvert Location
 - Point of Common Coupling
 - Mainland Cable Vault (Potential Location)
 - Island Cable Vault
 - Aboveground Storage Tanks (Potential Location)
 - Constructible Area (No Proposed Changes)
 - Constructible Area (Removed)
 - Mainland Dock (Potential Location)
 - Island Dock
 - Batch Plant (Potential Location)
 - Site Office (Potential Location)
 - Storage Shed
 - Transmission Lines**
 - Mainland Option 1
 - Mainland Option 2
 - Island Transmission Line
 - Land Use**
 - Central Staging Area
 - Switching Station (Potential Location)
 - Existing Features**
 - Road
 - Unopened Road Allowance
 - Railway
 - Hydro Line
 - Watercourse
 - Waterbody
 - Wooded Area
 - Property Line

Notes

- Coordinate System: NAD 1983 UTM Zone 18N
- Base features produced under license with the Ontario Ministry of Natural Resources and Forestry © Queen's Printer for Ontario, 2015.

Client/Project
 Windlectric Inc.
 Amherst Island Wind Energy Project

Figure No.
 1

Title
 Project Location - Modification #4:
 Overview

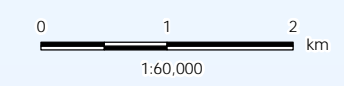

\\Cd1220-102\01609\active\60960595\drawing\MXD\APC.Mod_Report_A\160960595_Fig1_ProjectLocation_Overview_20150506.mxd
 Revised: 2015-05-11 By: pwnorsell
 4885000

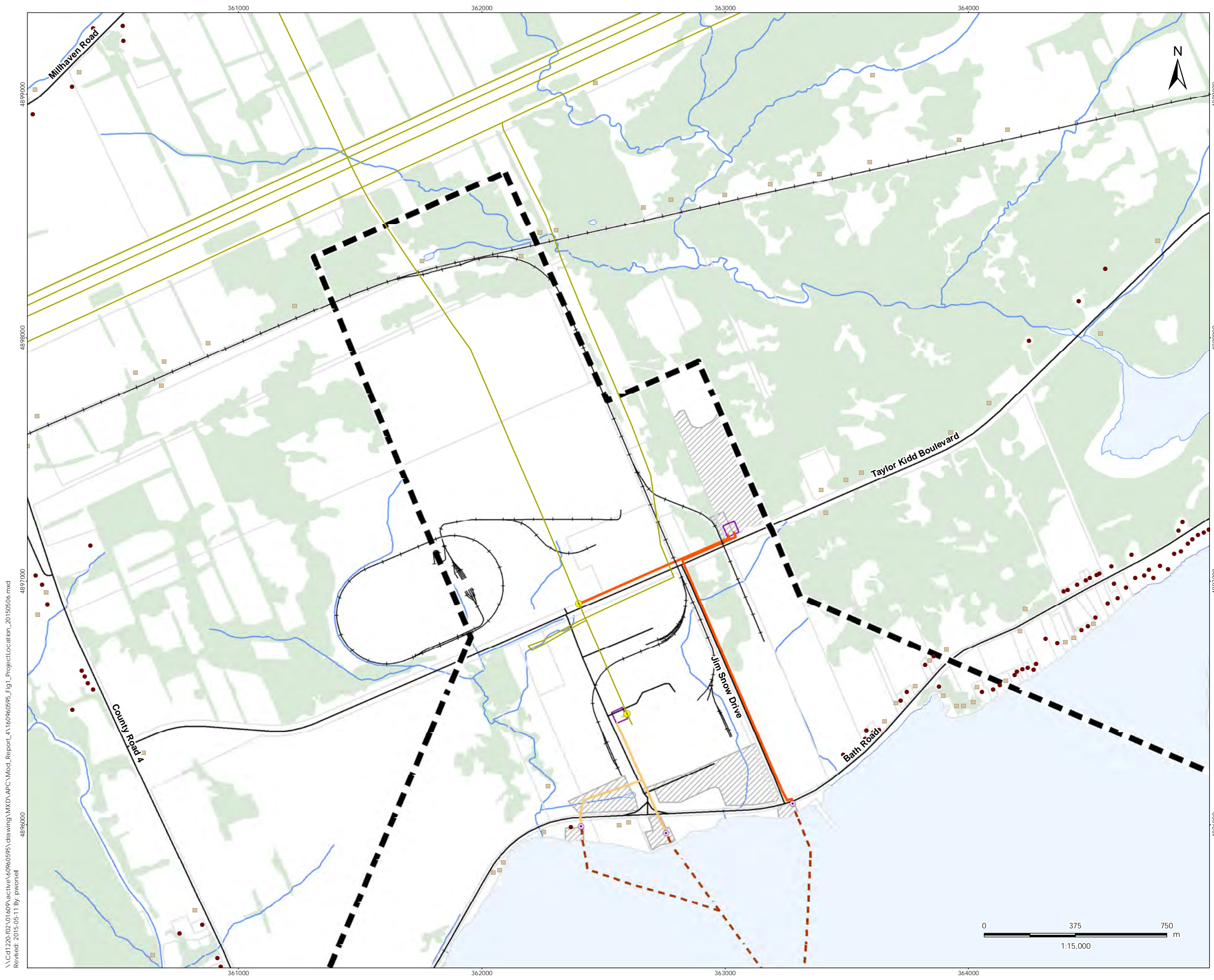

- Legend**
- Study Area
 - 120m Zone of Investigation
 - Project Components**
 - Turbine (No Changes Proposed)
 - Turbine (Removed)
 - Met Tower - Potential Location (No Changes Proposed)
 - Met Tower - Potential Location (Removed)
 - Access Road (No Changes Proposed)
 - Access Road (Removed)
 - Collector Line (No Changes Proposed)
 - Collector Line (New)
 - Collector Line (Removed)
 - Submarine Cable Path
 - Laydown Area and Crane Pad (No Changes Proposed)
 - Laydown Area and Crane Pad (Removed)
 - Operation and Maintenance Building (Potential Location)
 - Turbine Blade Tip (No Changes Proposed)
 - Turbine Blade Tip (Removed)
 - Substation (Potential Location)
 - Potential Culvert Location
 - Point of Common Coupling
 - Mainland Cable Vault (Potential Location)
 - Island Cable Vault
 - Aboveground Storage Tanks (Potential Location)
 - Constructible Area (No Proposed Changes)
 - Constructible Area (Removed)
 - Mainland Dock (Potential Location)
 - Island Dock
 - Batch Plant (Potential Location)
 - Site Office (Potential Location)
 - Storage Shed
 - Transmission Lines**
 - Mainland Option 1
 - Mainland Option 2
 - Island Transmission Line
 - Land Use**
 - Central Staging Area
 - Switching Station (Potential Location)
 - Noise Receptors**
 - Existing
 - Vacant
 - Existing Features**
 - Road
 - Unopened Road Allowance
 - Railway
 - Hydro Line
 - Watercourse
 - Waterbody
 - Wooded Area
 - Property Line

Notes

- Coordinate System: NAD 1983 UTM Zone 18N
- Base features produced under license with the Ontario Ministry of Natural Resources and Forestry © Queen's Printer for Ontario, 2015.

Client/Project

Windlectric Inc.
Amherst Island Wind Energy Project

Figure No.
1.1

Title
Project Location - Modification #4

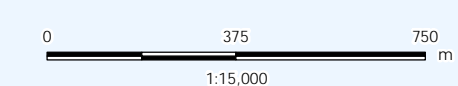

\\Cd1220-102\01609\active\60960595\drawing\MXD\APC_Mod_Report_A\160960595_Fig1_ProjectLocation_20150506.mxd
 Revised: 2015-05-11 By: pworsell

361000 362000 363000 364000 365000

4894000
4893000
4892000
4891000



Legend

- Study Area
- 120m Zone of Investigation
- Project Components
 - Turbine (No Changes Proposed)
 - Turbine (Removed)
 - Met Tower - Potential Location (No Changes Proposed)
 - Met Tower - Potential Location (Removed)
 - Access Road (No Changes Proposed)
 - Access Road (Removed)
 - Collector Line (No Changes Proposed)
 - Collector Line (New)
 - Collector Line (Removed)
 - Submarine Cable Path
 - Laydown Area and Crane Pad (No Changes Proposed)
 - Laydown Area and Crane Pad (Removed)
 - Operation and Maintenance Building (Potential Location)
 - Turbine Blade Tip (No Changes Proposed)
 - Turbine Blade Tip (Removed)
 - Substation (Potential Location)
 - Potential Culvert Location
 - Point of Common Coupling
 - Mainland Cable Vault (Potential Location)
 - Island Cable Vault
 - Aboveground Storage Tanks (Potential Location)
 - Constructible Area (No Proposed Changes)
 - Constructible Area (Removed)
 - Mainland Dock (Potential Location)
 - Island Dock
 - Batch Plant (Potential Location)
 - Site Office (Potential Location)
 - Storage Shed
- Transmission Lines
 - Mainland Option 1
 - Mainland Option 2
 - Island Transmission Line
- Land Use
 - Central Staging Area
 - Switching Station (Potential Location)
- Noise Receptors
 - Existing
 - Vacant
- Existing Features
 - Road
 - Unopened Road Allowance
 - Railway
 - Hydro Line
 - Watercourse
 - Waterbody
 - Wooded Area
 - Property Line

Notes

- Coordinate System: NAD 1983 UTM Zone 18N
- Base features produced under license with the Ontario Ministry of Natural Resources and Forestry © Queen's Printer for Ontario, 2015.

May 2015
160960595

Client/Project

Windlectric Inc.
Amherst Island Wind Energy Project

Figure No.

1.2

Title

Project Location - Modification #4

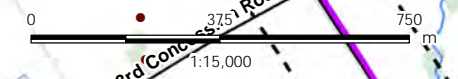

\\C01220-102\01609\active\60960595\drawing\MXD\APC\Mcd_Report_A\160960595_Fig1_ProjectLocation_20150506.mxd
Revised: 2015-05-11 By: pworsell

366000 367000 368000 369000 370000



Legend

- Study Area
- 120m Zone of Investigation
- Project Components
 - Turbine (No Changes Proposed)
 - Turbine (Removed)
 - Met Tower - Potential Location (No Changes Proposed)
 - Met Tower - Potential Location (Removed)
 - Access Road (No Changes Proposed)
 - Access Road (Removed)
 - Collector Line (No Changes Proposed)
 - Collector Line (New)
 - Collector Line (Removed)
 - Submarine Cable Path
 - Laydown Area and Crane Pad (No Changes Proposed)
 - Laydown Area and Crane Pad (Removed)
 - Operation and Maintenance Building (Potential Location)
 - Turbine Blade Tip (No Changes Proposed)
 - Turbine Blade Tip (Removed)
 - Substation (Potential Location)
 - Potential Culvert Location
 - Point of Common Coupling
 - Mainland Cable Vault (Potential Location)
 - Island Cable Vault
 - Aboveground Storage Tanks (Potential Location)
 - Constructible Area (No Proposed Changes)
 - Constructible Area (Removed)
 - Mainland Dock (Potential Location)
 - Island Dock
 - Batch Plant (Potential Location)
 - Site Office (Potential Location)
 - Storage Shed
- Transmission Lines
 - Mainland Option 1
 - Mainland Option 2
 - Island Transmission Line
- Land Use
 - Central Staging Area
 - Switching Station (Potential Location)
- Noise Receptors
 - Existing
 - Vacant
- Existing Features
 - Road
 - Unopened Road Allowance
 - Railway
 - Hydro Line
 - Watercourse
 - Waterbody
 - Wooded Area
 - Property Line

Notes

- Coordinate System: NAD 1983 UTM Zone 18N
- Base features produced under license with the Ontario Ministry of Natural Resources and Forestry © Queen's Printer for Ontario, 2015.

Client/Project
Windlectric Inc.
Amherst Island Wind Energy Project

Figure No.
1.3

Title
Project Location - Modification #4

\\Cd1220-102\01609\active\6960595\drawing\MXD\APC\Mod_Report_A\160960595_Fig1_ProjectLocation_20150506.mxd
 Revised: 2015-05-11 By: pworsell

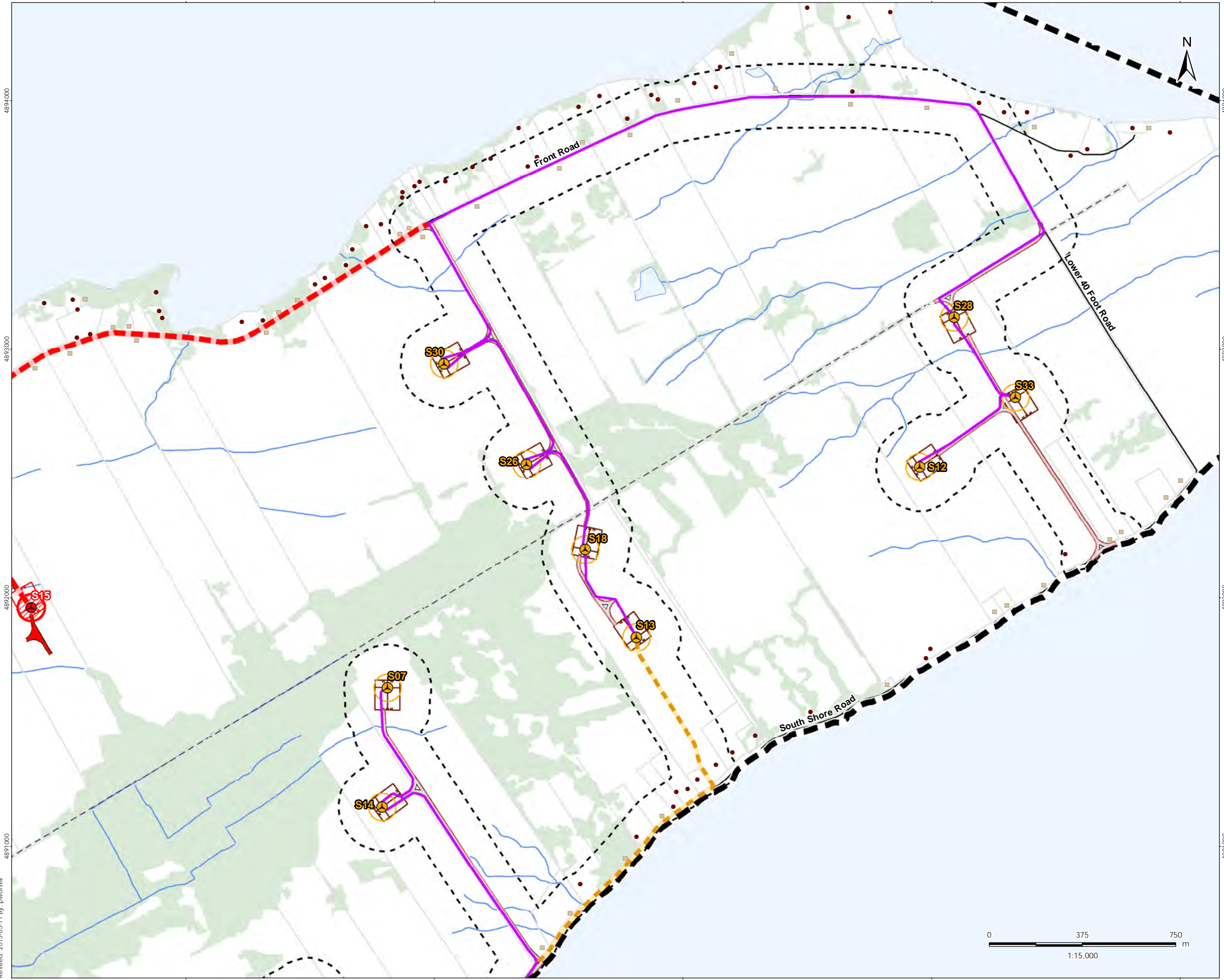

366000 367000 368000 369000 370000

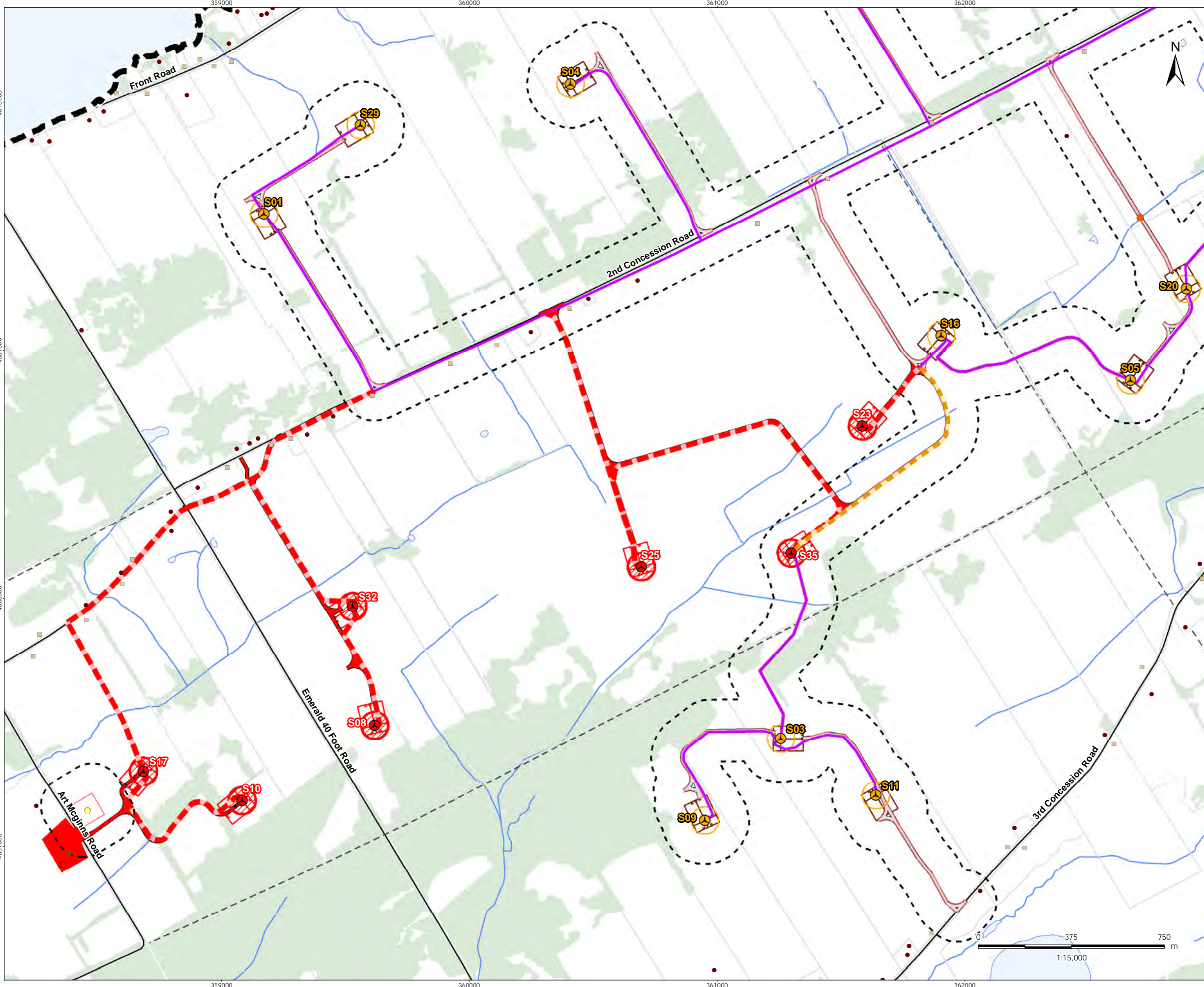

- Legend**
- Study Area
 - 120m Zone of Investigation
 - Project Components**
 - Turbine (No Changes Proposed)
 - Turbine (Removed)
 - Met Tower - Potential Location (No Changes Proposed)
 - Met Tower - Potential Location (Removed)
 - Access Road (No Changes Proposed)
 - Access Road (Removed)
 - Collector Line (No Changes Proposed)
 - Collector Line (New)
 - Collector Line (Removed)
 - Submarine Cable Path
 - Laydown Area and Crane Pad (No Changes Proposed)
 - Laydown Area and Crane Pad (Removed)
 - Operation and Maintenance Building (Potential Location)
 - Turbine Blade Tip (No Changes Proposed)
 - Turbine Blade Tip (Removed)
 - Substation (Potential Location)
 - Potential Culvert Location
 - Point of Common Coupling
 - Mainland Cable Vault (Potential Location)
 - Island Cable Vault
 - Aboveground Storage Tanks (Potential Location)
 - Constructible Area (No Proposed Changes)
 - Constructible Area (Removed)
 - Mainland Dock (Potential Location)
 - Island Dock
 - Batch Plant (Potential Location)
 - Site Office (Potential Location)
 - Storage Shed
 - Transmission Lines**
 - Mainland Option 1
 - Mainland Option 2
 - Island Transmission Line
 - Land Use**
 - Central Staging Area
 - Switching Station (Potential Location)
 - Noise Receptors**
 - Existing
 - Vacant
 - Existing Features**
 - Road
 - Unopened Road Allowance
 - Railway
 - Hydro Line
 - Watercourse
 - Waterbody
 - Wooded Area
 - Property Line

Notes

- Coordinate System: NAD 1983 UTM Zone 18N
- Base features produced under license with the Ontario Ministry of Natural Resources and Forestry © Queen's Printer for Ontario, 2015.

Client/Project
Windlectric Inc.
Amherst Island Wind Energy Project

Figure No.
1.4

Title
Project Location - Modification #4

\\C01220-102\01609\active\6960595\drawing\MXD\APC_Mod_Report_A\160960595_Fig1_ProjectLocation_20150506.mxd
 Revised: 2015-05-11 By: pworsell

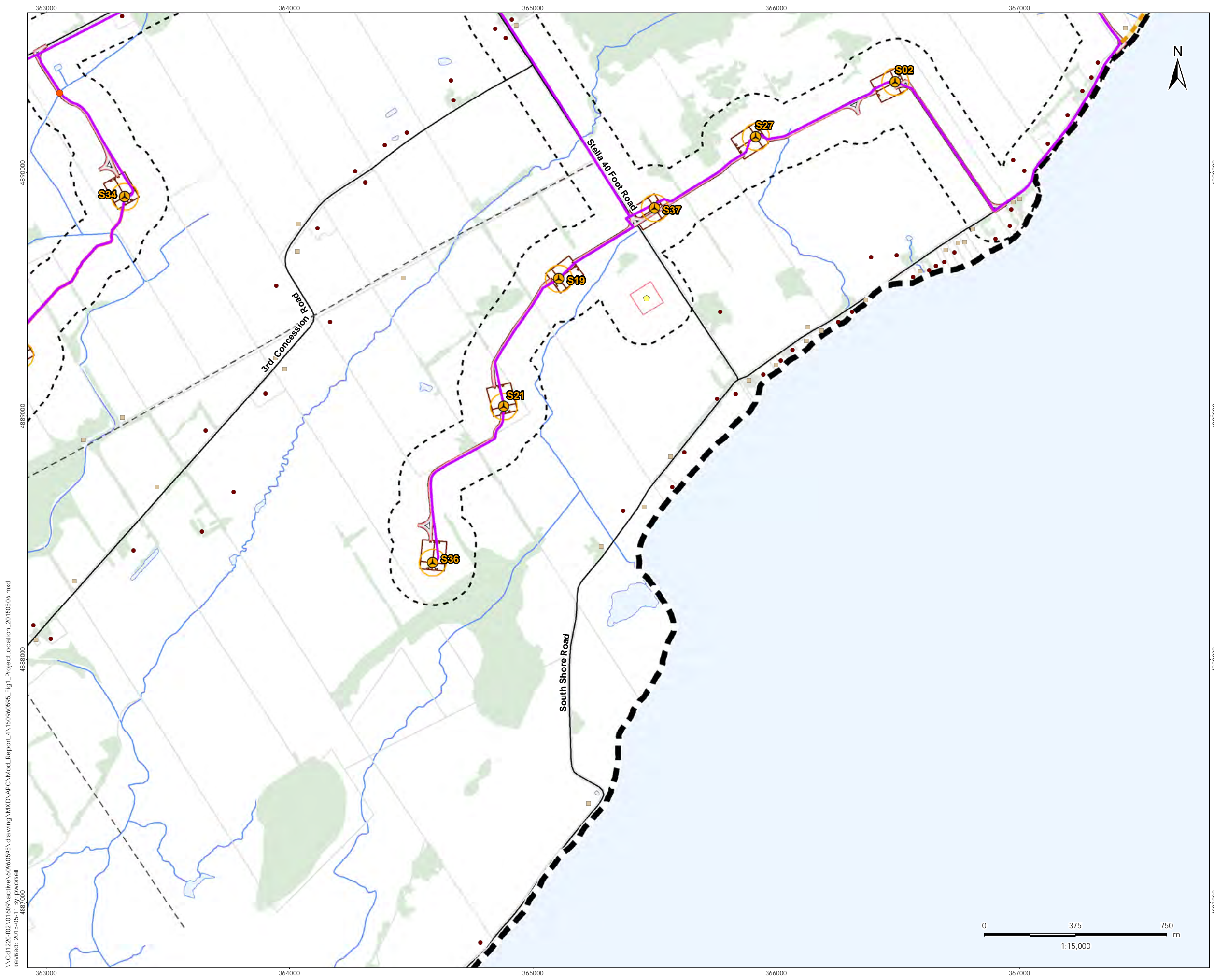

- Legend**
- Study Area
 - 120m Zone of Investigation
 - Project Components**
 - Turbine (No Changes Proposed)
 - Turbine (Removed)
 - Met Tower - Potential Location (No Changes Proposed)
 - Met Tower - Potential Location (Removed)
 - Access Road (No Changes Proposed)
 - Access Road (Removed)
 - Collector Line (No Changes Proposed)
 - Collector Line (New)
 - Collector Line (Removed)
 - Submarine Cable Path
 - Laydown Area and Crane Pad (No Changes Proposed)
 - Laydown Area and Crane Pad (Removed)
 - Operation and Maintenance Building (Potential Location)
 - Turbine Blade Tip (No Changes Proposed)
 - Turbine Blade Tip (Removed)
 - Substation (Potential Location)
 - Potential Culvert Location
 - Point of Common Coupling
 - Mainland Cable Vault (Potential Location)
 - Island Cable Vault
 - Aboveground Storage Tanks (Potential Location)
 - Constructible Area (No Proposed Changes)
 - Constructible Area (Removed)
 - Mainland Dock (Potential Location)
 - Island Dock
 - Batch Plant (Potential Location)
 - Site Office (Potential Location)
 - Storage Shed
 - Transmission Lines**
 - Mainland Option 1
 - Mainland Option 2
 - Island Transmission Line
 - Land Use**
 - Central Staging Area
 - Switching Station (Potential Location)
 - Noise Receptors**
 - Existing
 - Vacant
 - Existing Features**
 - Road
 - Unopened Road Allowance
 - Railway
 - Hydro Line
 - Watercourse
 - Waterbody
 - Wooded Area
 - Property Line

Notes

- Coordinate System: NAD 1983 UTM Zone 18N
- Base features produced under license with the Ontario Ministry of Natural Resources and Forestry © Queen's Printer for Ontario, 2015.

Client/Project
Windlectric Inc.
Amherst Island Wind Energy Project

Figure No.
1.5

Title
Project Location - Modification #4

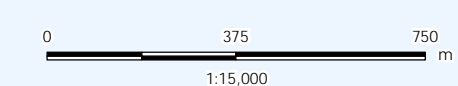

\\Cd1220-102\01609\active\6960595\drawing\MXD\APC_Mod_Report_A\160960595_Fig1_ProjectLocation_20150506.mxd
 Revised: 2015-05-11 By: pwnorsell
 4887000

Appendix B:

WAWBR Revised Figures and Tables

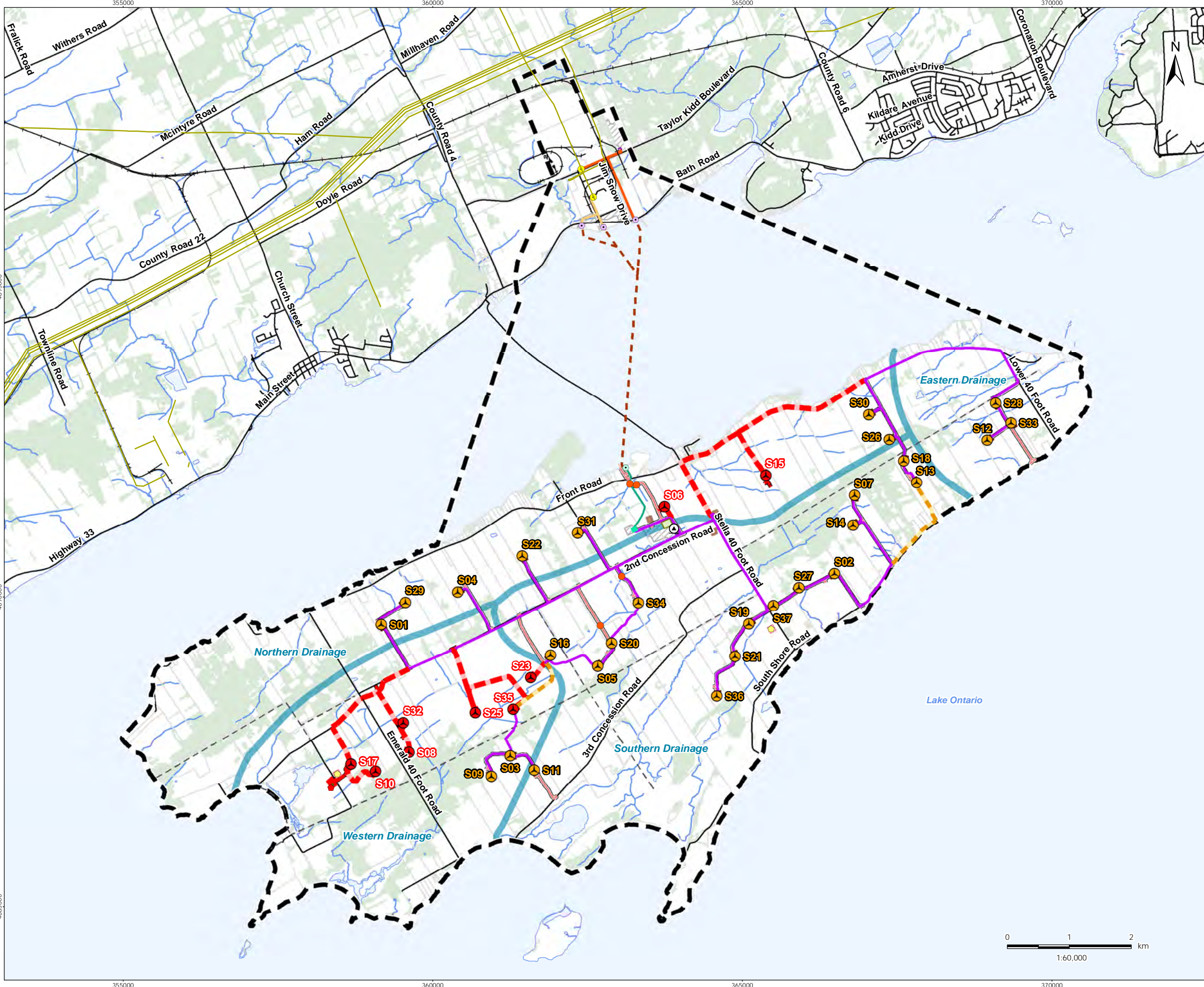

- Legend**
- Study Area
 - 120m Zone of Investigation
 - Project Components**
 - Turbine (No Changes Proposed)
 - Turbine (Removed)
 - Met Tower - Potential Location (No Changes Proposed)
 - Met Tower - Potential Location (Removed)
 - Access Road (No Changes Proposed)
 - Access Road (Removed)
 - Collector Line (No Changes Proposed)
 - Collector Line (New)
 - Collector Line (Removed)
 - Submarine Cable Path
 - Laydown Area and Crane Pad (No Changes Proposed)
 - Laydown Area and Crane Pad (Removed)
 - Operation and Maintenance Building (Potential Location)
 - Turbine Blade Tip (No Changes Proposed)
 - Turbine Blade Tip (Removed)
 - Substation (Potential Location)
 - Potential Culvert Location
 - Point of Common Coupling
 - Mainland Cable Vault (Potential Location)
 - Island Cable Vault
 - Aboveground Storage Tanks (Potential Location)
 - Constructible Area (No Proposed Changes)
 - Constructible Area (Removed)
 - Mainland Dock (Potential Location)
 - Island Dock
 - Batch Plant (Potential Location)
 - Site Office (Potential Location)
 - Storage Shed
 - Transmission Lines**
 - Mainland Option 1
 - Mainland Option 2
 - Island Transmission Line
 - Land Use**
 - Central Staging Area
 - Switching Station (Potential Location)
 - Existing Features**
 - Road
 - Unopened Road Allowance
 - Railway
 - Hydro Line
 - Watercourse
 - Waterbody
 - Wooded Area
 - Property Line
 - Drainage Area

Notes

- Coordinate System: NAD 1983 UTM Zone 18N
- Base features produced under license with the Ontario Ministry of Natural Resources and Forestry © Queen's Printer for Ontario, 2015.

Client/Project
 Windlectric Inc.
 Amherst Island Wind Energy Project

Figure No.
 1
 Title

Location of Study Area and Subwatersheds

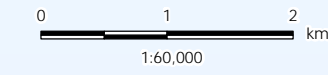

W:\active\60960595\drawing\MXD\Aquatics\ReportFigures\WaterBody_Report\Mod_Report\160960595_Fig_LocationStudyArea_20150116.mxd
 Revised: 2015-05-07 By: dhanvey
 4885000

356000 357000 358000 359000 360000 361000 362000



Legend

- Study Area
- 120m Zone of Investigation
- Project Components
 - Turbine (No Changes Proposed)
 - Turbine (Removed)
 - Met Tower - Potential Location (No Changes Proposed)
 - Met Tower - Potential Location (Removed)
 - Access Road (No Changes Proposed)
 - Access Road (Removed)
 - Collector Line (No Changes Proposed)
 - Collector Line (New)
 - Collector Line (Removed)
 - Submarine Cable Path
 - Laydown Area and Crane Pad (No Changes Proposed)
 - Laydown Area and Crane Pad (Removed)
 - Operation and Maintenance Building (Potential Location)
 - Turbine Blade Tip (No Changes Proposed)
 - Turbine Blade Tip (Removed)
 - Substation (Potential Location)
 - Potential Culvert Location
 - Point of Common Coupling
 - Mainland Cable Vault (Potential Location)
 - Island Cable Vault
 - Aboveground Storage Tanks (Potential Location)
 - Constructible Area (No Proposed Changes)
 - Constructible Area (Removed)
 - Mainland Dock (Potential Location)
 - Island Dock
 - Batch Plant (Potential Location)
 - Site Office (Potential Location)
 - Storage Shed
- Transmission Lines
 - Mainland Option 1
 - Mainland Option 2
 - Island Transmission Line
- Land Use
 - Central Staging Area
 - Switching Station (Potential Location)
- Existing Features
 - Road
 - Unopened Road Allowance
 - Railway
 - Watercourse (modified by Stantec)
 - Direction of Flow
 - Property Line
 - REA Water Body
 - Not a REA Water Body
 - Water Assessment Station Number
 - Drainage Area

Notes

- Coordinate System: NAD 1983 UTM Zone 18N
- Base features produced under license with the Ontario Ministry of Natural Resources © Queen's Printer for Ontario, 2015.
- Orthoimagery © First Base Solutions, 2015. Imagery taken in 2008.

May 2015
160960595

Client/Project

Windlectric Inc.
Amherst Island Wind Energy Project

Figure No.
2 (1 of 4)

Title
Water Body Locations and
Water Assessment Survey Stations

W:\active\160960595\drawing\MXD\Aquatics\Report\Figures\WaterBody_Location_SurveyStations_20150116.mxd
Revised: 2015-05-07 By: dhanvey

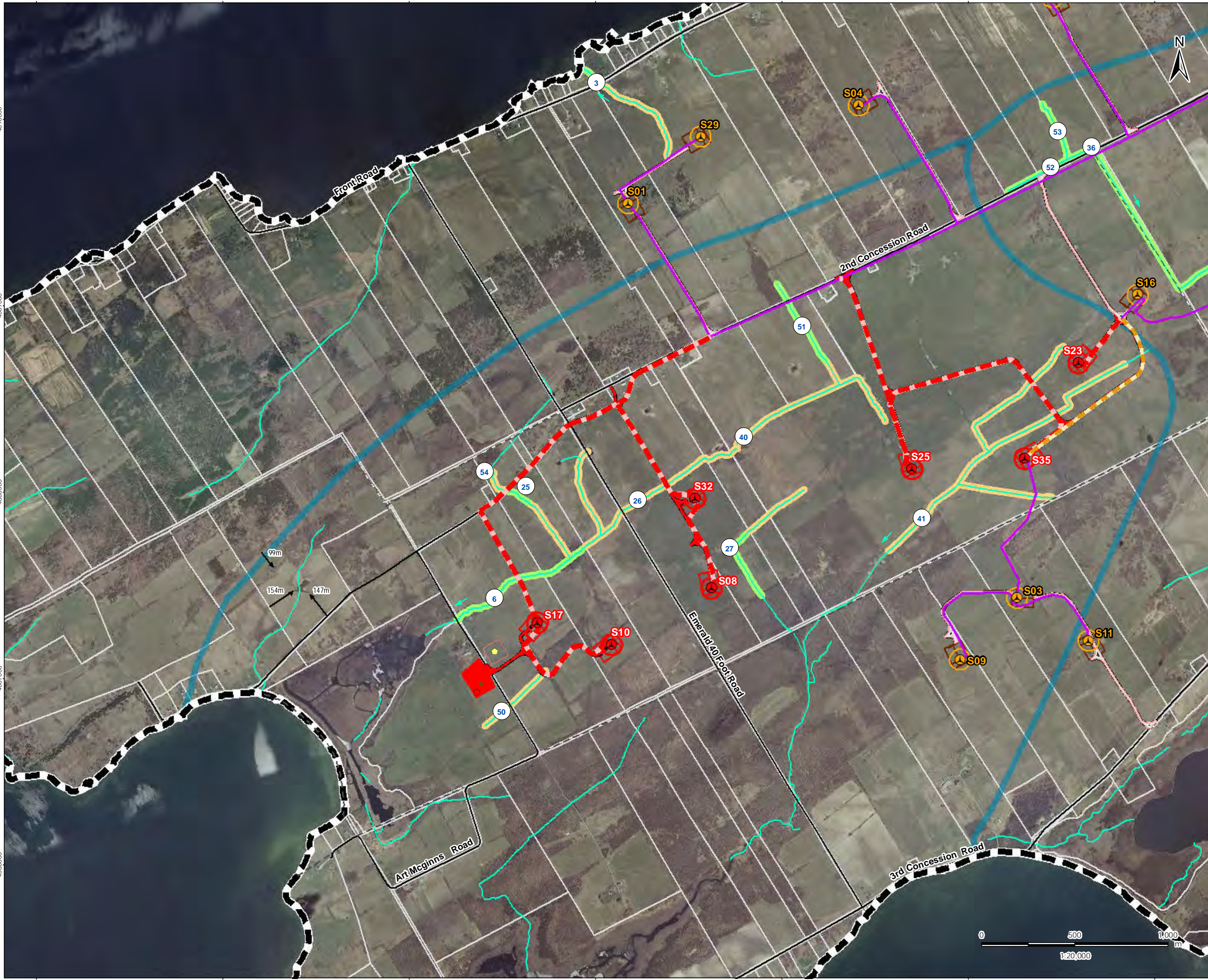

356000 357000 358000 359000 360000 361000 362000

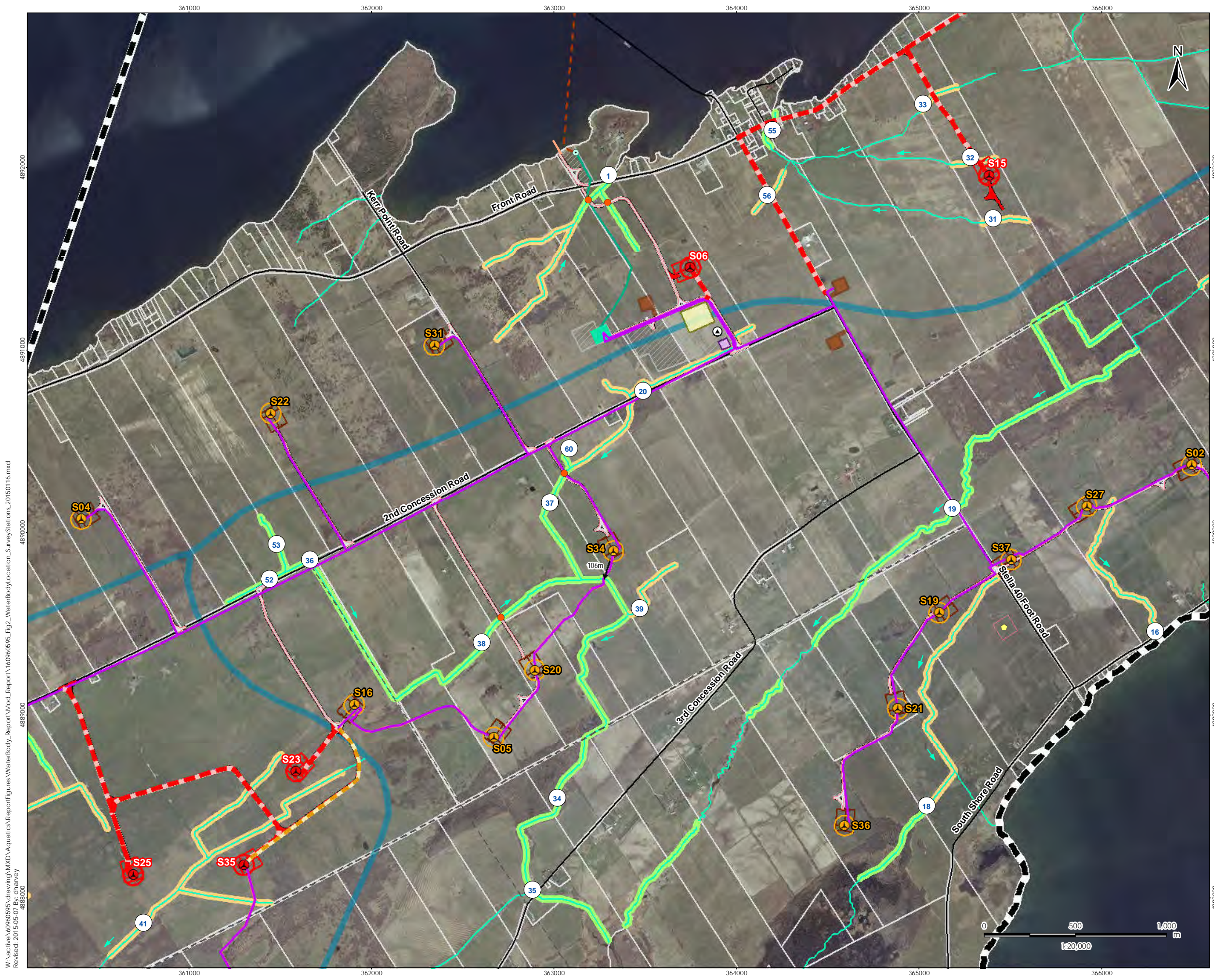

- Legend**
- Study Area
 - 120m Zone of Investigation
 - Project Components**
 - Turbine (No Changes Proposed)
 - Turbine (Removed)
 - Met Tower - Potential Location (No Changes Proposed)
 - Met Tower - Potential Location (Removed)
 - Access Road (No Changes Proposed)
 - Access Road (Removed)
 - Collector Line (No Changes Proposed)
 - Collector Line (New)
 - Collector Line (Removed)
 - Submarine Cable Path
 - Laydown Area and Crane Pad (No Changes Proposed)
 - Laydown Area and Crane Pad (Removed)
 - Operation and Maintenance Building (Potential Location)
 - Turbine Blade Tip (No Changes Proposed)
 - Turbine Blade Tip (Removed)
 - Substation (Potential Location)
 - Potential Culvert Location
 - Point of Common Coupling
 - Mainland Cable Vault (Potential Location)
 - Island Cable Vault
 - Aboveground Storage Tanks (Potential Location)
 - Constructible Area (No Proposed Changes)
 - Constructible Area (Removed)
 - Mainland Dock (Potential Location)
 - Island Dock
 - Batch Plant (Potential Location)
 - Site Office (Potential Location)
 - Storage Shed
 - Transmission Lines**
 - Mainland Option 1
 - Mainland Option 2
 - Island Transmission Line
 - Land Use**
 - Central Staging Area
 - Switching Station (Potential Location)
 - Existing Features**
 - Road
 - Unopened Road Allowance
 - Railway
 - Watercourse (modified by Stantec)
 - Direction of Flow
 - Property Line
 - REA Water Body
 - Not a REA Water Body
 - Water Assessment Station Number
 - Drainage Area

Notes

- Coordinate System: NAD 1983 UTM Zone 18N
- Base features produced under license with the Ontario Ministry of Natural Resources © Queen's Printer for Ontario, 2015.
- Orthoimagery © First Base Solutions, 2015. Imagery taken in 2008.

Client/Project
 Windlectric Inc.
 Amherst Island Wind Energy Project

Figure No.
 2 (2 of 4)

Title
 Water Body Locations and
 Water Assessment Survey Stations

W:\active\60960595\drawing\MXD\Aquatics\Report\Figures\WaterBody_Location_Fig2_WaterBody_Location_SurveyStations_20150116.mxd
 Revised: 2015-05-07 By: dhanvey

May 2015
 160960595

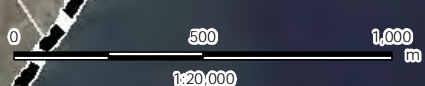

365000 366000 367000 368000 369000 370000



W:\active\60960595\drawing\MXD\Aquatics\Report\Fig2_WaterBodyLocation_SurveyStations_20150116.mxd
Revised: 2015-05-07 By: dhaney



Legend

- Study Area
- 120m Zone of Investigation
- Project Components
 - Turbine (No Changes Proposed)
 - Turbine (Removed)
 - Met Tower - Potential Location (No Changes Proposed)
 - Met Tower - Potential Location (Removed)
 - Access Road (No Changes Proposed)
 - Access Road (Removed)
 - Collector Line (No Changes Proposed)
 - Collector Line (New)
 - Collector Line (Removed)
 - Submarine Cable Path
 - Laydown Area and Crane Pad (No Changes Proposed)
 - Laydown Area and Crane Pad (Removed)
 - Operation and Maintenance Building (Potential Location)
 - Turbine Blade Tip (No Changes Proposed)
 - Turbine Blade Tip (Removed)
 - Substation (Potential Location)
 - Potential Culvert Location
 - Point of Common Coupling
 - Mainland Cable Vault (Potential Location)
 - Island Cable Vault
 - Aboveground Storage Tanks (Potential Location)
 - Constructible Area (No Proposed Changes)
 - Constructible Area (Removed)
 - Mainland Dock (Potential Location)
 - Island Dock
 - Batch Plant (Potential Location)
 - Site Office (Potential Location)
 - Storage Shed
- Transmission Lines
 - Mainland Option 1
 - Mainland Option 2
 - Island Transmission Line
- Land Use
 - Central Staging Area
 - Switching Station (Potential Location)
- Existing Features
 - Road
 - Unopened Road Allowance
 - Railway
 - Watercourse (modified by Stantec)
 - Direction of Flow
 - Property Line
 - REA Water Body
 - Not a REA Water Body
 - Water Assessment Station Number
 - Drainage Area

Notes

- Coordinate System: NAD 1983 UTM Zone 18N
- Base features produced under license with the Ontario Ministry of Natural Resources © Queen's Printer for Ontario, 2015.
- Orthoimagery © First Base Solutions, 2015. Imagery taken in 2008.

May 2015
160960595

Client/Project

Windlectric Inc.
Amherst Island Wind Energy Project

Figure No.

2 (3 of 4)

Title

Water Body Locations and
Water Assessment Survey Stations





- Legend**
- Study Area
 - 120m Zone of Investigation
 - Project Components**
 - Turbine (No Changes Proposed)
 - Turbine (Removed)
 - Met Tower - Potential Location (No Changes Proposed)
 - Met Tower - Potential Location (Removed)
 - Access Road (No Changes Proposed)
 - Access Road (Removed)
 - Collector Line (No Changes Proposed)
 - Collector Line (New)
 - Collector Line (Removed)
 - Submarine Cable Path
 - Laydown Area and Crane Pad (No Changes Proposed)
 - Laydown Area and Crane Pad (Removed)
 - Operation and Maintenance Building (Potential Location)
 - Turbine Blade Tip (No Changes Proposed)
 - Turbine Blade Tip (Removed)
 - Substation (Potential Location)
 - Potential Culvert Location
 - Point of Common Coupling
 - Mainland Cable Vault (Potential Location)
 - Island Cable Vault
 - Aboveground Storage Tanks (Potential Location)
 - Constructible Area (No Proposed Changes)
 - Constructible Area (Removed)
 - Mainland Dock (Potential Location)
 - Island Dock
 - Batch Plant (Potential Location)
 - Site Office (Potential Location)
 - Storage Shed
 - Transmission Lines**
 - Mainland Option 1
 - Mainland Option 2
 - Island Transmission Line
 - Land Use**
 - Central Staging Area
 - Switching Station (Potential Location)
 - Existing Features**
 - Road
 - Unopened Road Allowance
 - Railway
 - Watercourse (modified by Stantec)
 - Direction of Flow
 - Property Line
 - REA Water Body
 - Not a REA Water Body
 - Water Assessment Station Number
 - Drainage Area

Notes

1. Coordinate System: NAD 1983 UTM Zone 18N
2. Base features produced under license with the Ontario Ministry of Natural Resources © Queen's Printer for Ontario, 2015.
3. Orthoimagery © First Base Solutions, 2015. Imagery taken in 2008.

Client/Project
 Windlectric Inc.
 Amherst Island Wind Energy Project

Figure No.
 2 (4 of 4)

Title
 Water Body Locations and
 Water Assessment Survey Stations

W:\active\60960595\drawing\MXD\Aquatics\Report\Figures\WaterBody_Report\Mxd_Report\160960595_Fig2_WaterBodyLocation_SurveyStations_20150116.mxd
 Revised: 2015-05-07 By: chanev

May 2015
 160960595

Table 3.1 (revised): Summary of mapped watercourses/waterbodies (LIO) in the Zone of Investigation and criteria for REA water bodies - Amherst Island Wind Project

Water Feature	WB Station(s)	NWB Station(s)	Tile No. in Figure 2	Water Body+			Criteria for Screening Out Mapped Watercourses (Not a Water Body)									Comments
				permanent stream	intermittent stream	seep++	No Surface Feature Present	Swale**	Grassed Waterway*	Temporary Channel for Surface Drainage*	Roadside Ditch*	Temporarily Poned Area Normally Farmed*	Dugout Pond*	Rock Chute*	Other	
Northern Drainage																
	1		2		✓											
		3	1							✓						No defined channel; cow pasture with active grazing.
		21	3							✓						Approx. 50m upstream of road, surficial drainage only (no channel).
Eastern Drainage																
	8		3		✓											
	9		3		✓											
		11	3							✓						
		28	3				✓			✓						
		30	3							✓						
	58		3		✓											
		59	3							✓						
Southern Drainage																
		10	3				✓									Diffuse surficial drainage.
		12	3							✓						Surficial drainage.
		13	3							✓						
		14	3							✓						Diffuse surficial drainage.
		16	2				✓			✓						Shallow furrows for surficial drainage.
		18	2				✓			✓						Not a WB within the Zone of Investigation; surficial drainage.
	19		2	✓												
		20	2								✓					Grassed ditch parallel to 2nd Concession.
	36		2		✓											
	37		2		✓											
	38		2		✓											
		39								✓						Surficial drainage through pasture, turns into a water body at confluence with Miller Drain (but outside of ZOI).

Table 3.1 (revised): Summary of mapped watercourses/waterbodies (LIO) in the Zone of Investigation and criteria for REA water bodies - Amherst Island Wind Project

Water Feature	WB Station(s)	NWB Station(s)	Tile No. in Figure 2	Water Body+			Criteria for Screening Out Mapped Watercourses (Not a Water Body)									Comments	
				permanent stream	intermittent stream	seep++	No Surface Feature Present	Swale**	Grassed Waterway*	Temporary Channel for Surface Drainage*	Roadside Ditch*	Temporarily Poned Area Normally Farmed*	Dugout Pond*	Rock Chute*	Other		
	52		2		✓												
	53		2		✓												Trapezoidal channel.
	60		2		✓												
Western Drainage																	
		41	1				✓										No defined channel; pasture.
	51		1		✓												
Mainland																	
		M1 Trib	4							✓							
	M2		4		✓												
	M3		4		✓												
	M4		4		✓												
	M9		4		✓												
	M7				✓												
	M10		4		✓												Lower portion near Taylor Kidd Road is not a water body.
		M11	4							✓							
Lake Ontario																	
	n/a		2 & 4	Lake													
Seeps																	
None	n/a																There were no groundwater seeps identified in the Project Location.

+ if all three criteria are 'no', then the feature is not a water body

++ a site of emergence of ground water where the water table is present at the ground surface, including a spring

** low lying feature with no defined channel and not dominated by aquatic vegetation

* as per REA Definition O. Reg 359/09

WB = Water Body

NWB = Non-Water Body

Table 3.2 (revised): Summary of Water Bodies and Project Components

Water Body	Crossing Class		Within 120 m				Fish Habitat	
	Access Road ^a	Collector Line	Turbine ^b	Access Road ^a	Collector Line	Substation/Switching Station/MET Tower	Direct Permanent (P) or Seasonal (S)	Indirect
Northern Drainage								
Station 1	S06 crosses twice	1	-	Dock	-	-	S	
Eastern Drainage								
Stations 30 and 58	-	1	-	-	-	-	S	
Station 9	-	1	-	-	-	-	S	
Station 8	-	1	-	S28	-	-	S	
Southern Drainage								
Station 19	-	1	-	-	-	-	P	
Stations 52, 36, 38, 34 and 35	S20	2	S34	S16	-	-	P	
Station 37 and 60	S34	-	-	-	-	-	S	
Station 53	-	1	-	S16	-	-	S	
Western Drainage								
Station 51	-	1	-	-	-	-	S	
Mainland								
Option 1								
M2					1		S	
M3		1					S	
M4/M9					1		S	
Option 2								
M2						1	S	
Lake Ontario								
Mainland				Facilities Dock and Submarine Cable Landing Area			P	
Island				Facilities Dock and Submarine Cable Landing Area			P	
Offshore				Submarine Cable on Lake Bottom			P	

^a includes crane path and underground collector line

^bturbine plus associated laydown area

Table 4.2 (revised): Summary of Water Bodies Within the 120 m Zone of Investigation					
Reach ID ^a	Site Description	Proposed Works ^{ab}	Potential Impacts	Mitigation	Net Effects ^c
Northern Drainage					
Tributary Associated with Station 1	Intermittent flow dominated by flat morphology. Bankfull width = 3 m. Water depth = 20 cm. Substrate = silt and gravel. Fished May 2011 (Stantec). Seasonal fish habitat.	Crossed twice by access road to Turbine S06 and once by a proposed collector line. Potential submarine cable landing area and dock to be located within 120 m of water body providing fish habitat.	Construction activities associated with the installation of the turbine access roads and culverts may affect the reach (e.g. Temporary increase in surface water turbidity due to runoff during construction (Section 5.1 and 5.2.) Construction activities within the constructible area of the cable landing and dock may affect the reach despite being outside of the constructible area (e.g. Temporary increase in surface water turbidity due to runoff during construction. (Section 5.1.)	See Sections 6.1, 6.2, 6.3. Follow DFO Operational Statement (OS) for Overhead Line Construction, Directional Drilling or Punch and Bore Crossings (Appendix E)	New access road culvert. As per preliminary agency consultation, effects of a culvert at this location can be mitigated. DFO consultation is ongoing and the Project will comply with required permits and/or conditions.
Eastern Drainage					
Tributary Associated with Station 30/58	Intermittent dry at the time of the field investigation. Bankfull width = 5 m. Water depth = n/a. Substrate = limestone bedrock, silt and detritus. Seasonal fish habitat.	Crossed by a proposed collector line along Front Road.	With the exception of standard construction activities, collector line crossings of a water body should not affect the reach outside the constructible area (see Sections 5.1, 5.3).	See Sections 6.1 and 6.3. Follow DFO OS for Overhead Line Construction, Directional Drilling or Punch and Bore Crossings (Appendix E).	None expected.
Tributary Associated with Station 9	Intermittent flow dominated by run and flat morphology, with occasional pools and riffles. Bankfull width = 4 m. Water depth = 30 cm. Substrate = bedrock, silt, gravel and detritus. Seasonal fish habitat.	Crossed by a proposed collector line along Lower 40 Foot Road.	With the exception of standard construction activities, collector line crossings of a water body should not affect the reach outside the constructible area (see Sections 5.1, 5.3).	See Sections 6.1 and 6.3. Follow DFO OS for Overhead Line Construction, Directional Drilling or Punch and Bore Crossings (Appendix E).	None expected.
Tributary Associated with Station 8	Intermittent flow dominated by pool and flat morphology. Bankfull width = 4 m. Water depth = 20 cm. Substrate = bedrock, silt, gravel and detritus. Seasonal fish habitat.	Crossed by a proposed collector line along Lower 40 Foot Road.	With the exception of standard construction activities, collector line crossings of a water body should not affect the reach outside the constructible area (see Sections 5.1, 5.3).	See Sections 6.1 and 6.3. Follow DFO OS for Overhead Line Construction, Directional Drilling or Punch and Bore Crossings (Appendix E).	None expected.
Southern Drainage					
Tributary Associated with Station 19	Permanent Flow dominated by run and flat morphology. Bankfull width = 4 m. Water depth = 60 cm to >1.5 m. Substrate = Silt and detritus. Fish habitat.	Crossed by a proposed collector line along Stella 40 Foot Road.	With the exception of standard construction activities, collector line crossings of a water body should not affect the reach outside the constructible area (see Sections 5.1, 5.3).	See Sections 6.1 and 6.3. DFO OS for Overhead Line Construction, Directional Drilling or Punch and Bore Crossings (Appendix E).	None expected.

Table 4.2 (revised): Summary of Water Bodies Within the 120 m Zone of Investigation

Reach ID ^a	Site Description	Proposed Works ^{ab}	Potential Impacts	Mitigation	Net Effects ^c
Miller Municipal Drain (Stations 52, 36, 38, 34 and 35)	Permanent flow dominated by pool and flat morphology (downstream areas). Upstream areas (Stns 52, 36, 38) are intermittent. Bankfull width = 3 to 15 m. Water depth = 15 cm. Substrate = Silt and clay. Fish habitat.	Crossed by an access road to Turbine S20 and twice by a proposed collector line along 2 nd Concession Road. Turbine S34, underground collector line and access road to S16 to be located within 120 m of water body providing fish habitat. Turbine S34 is located 106 m from a water body.	Construction activities associated with the installation of the turbine and turbine access roads may affect the reach (e.g. Temporary increase in surface water turbidity due to runoff during construction See Section 5.1 and 5.2). With the exception of standard construction activities, collector line crossings of a water body should not affect the reach outside the constructible area (see Sections 5.1, 5.3).	See Sections 6.1, 6.2, 6.3/6.4. Follow DFO OS for Overhead Line Construction, Directional Drilling or Punch and Bore Crossings (Appendix E).	New access road culvert. As per preliminary agency consultation, effects of a culvert at this location can be mitigated. DFO consultation is ongoing and the Project will comply with required permits and/or conditions.
Tributary Associated with Station 37/60	Intermittent flow dominated by float morphology. Bankfull width = 4 m. Water depth = 20 cm. Substrate = Silt and clay. Seasonal fish habitat.	Crossed by an access road to Turbine S34.	Construction activities associated with the installation of the turbine access roads may affect the reach (e.g. Temporary increase in surface water turbidity due to runoff during construction (Section 5.1 and 5.2).	See Sections 6.1 and 6.2.	New access road culvert. As per preliminary agency consultation, effects of a culvert at this location can be mitigated. DFO consultation is ongoing and the Project will comply with required permits and/or conditions.
Tributary Associated with Station 53	Intermittent flow that was dry at the time of the field investigation. Bankfull width = 1.5 m. Water depth = n/a. Substrate = silt, clay and muck. Seasonal fish habitat.	Located within 120 m of a proposed collector line.	With the exception of standard construction activities, collector lines located within 120 m of a water body should not affect the reach outside the constructible area (see Section 5.1).	See Section 6.1.	None expected.
Western Drainage					
Tributary Associated with Station 51	Likely intermittent flow dominated by pool and flat morphology. Bankfull width = 2.2 m. Water depth = 15 cm. Substrate = sand, silt, clay and detritus. Likely seasonal fish habitat.	Crossed by a proposed collector line.	With the exception of standard construction activities, collector line crossings of a water body should not affect the reach outside the constructible area (see Sections 5.1, 5.3).	See Sections 6.1 and 6.3. Follow DFO OS for Overhead Line Construction, Directional Drilling or Punch and Bore Crossings (Appendix E)	None expected.
Mainland					
Tributary Associated with Station M2	Intermittent flow that was dry at the time of the field visit. Bankfull width = 1.5 m. Water depth = dry. Substrate = Silt, muck, sand, cobble and detritus. Seasonal fish habitat.	<i>Option 1</i> Located within proposed Laydown Area <i>Option 2</i> Located within 120 m of a proposed collector line and dock location.	With the exception of standard construction activities, collector lines and docks located within 120 m of a water body should not affect the reach outside the constructible area (see Section 5.1).	See Section 6.1.	None expected.
Tributary Associated with Station M3	Intermittent flow that was dry at the time of the field visit. Bankfull width = 1 m. Water depth = dry. Substrate = soil. Seasonal fish habitat.	<i>Option 2</i> Crossed by a proposed collector line.	With the exception of standard construction activities, collector line crossings of a water body should not affect the reach outside the constructible area (see Sections 5.1, 5.3).	See Sections 6.1 and 6.3. Follow DFO OS for Overhead Line Construction, Directional Drilling or Punch and Bore Crossings (Appendix E)	None expected.

Table 4.2 (revised): Summary of Water Bodies Within the 120 m Zone of Investigation

Reach ID ^a	Site Description	Proposed Works ^{ab}	Potential Impacts	Mitigation	Net Effects ^c
Tributary Associated with Station M9/M4	Likely intermittent flow, dominated by flat and pool morphology. Bankfull width = 2 m. Water depth = 15 cm. Substrate = silt, clay, marl, muck and detritus. Likely seasonal fish habitat.	<i>Option 2</i> Within 120 m of a proposed collector line.	With the exception of standard construction activities, collector line crossings of a water body should not affect the reach outside the constructible area (see Section 5.1).	See Section 6.1.	None expected.
Lake Ontario					
Amherst Island Shoreline	Littoral zone of Lake Ontario. Bedrock with scattered cobble and sparse vegetation. Habitat for warmwater fish species.	Dock and Cable Landing Final dock design - to be determined (no infilling required). Cable landing area – bury cable in trench to approx. 100 m from the average high water mark; clamshell armour to be used from end of trench to 3 m depth (under average water level conditions?)	Dock construction and operation – Section 5.4. Cable Landing – Section 5.5.	See Sections 6.4 and 6.5.	New dock structure on island shoreline; although there will be a permanent footprint of the dock footings, effects can be mitigated. DFO consultation is ongoing and the Project will comply with required permits and/or conditions..
Mainland Shoreline	Littoral zone of Lake Ontario. Habitat for warmwater fish species at all three locations. <i>West Option:</i> Sand. <i>Centre Option:</i> Sand and cobble with scattered vegetation. <i>East Option:</i> Predominantly sand with scattered vegetation; steeper slope relative to the West and Centre options. <i>Optional Cable Landing:</i> Sand with patchy vegetation; gradual slope.	Dock and Cable Landing Final dock design - to be determined (no infilling required). Cable landing area – bury cable in trench to approx. 100 m from the average high water mark; clamshell armour to be used from end of trench to 3 m depth (under average water level conditions).	Dock construction and operation – Section 5.4. Cable landing – Section 5.5.	See Sections 6.4 and 6.5 and DFO OS for Underwater Cables (Appendix E).	New dock structure on shoreline; although there will be a footprint of the dock footings, effects can be mitigated. DFO consultation is ongoing and the Project will comply with required permits and/or conditions..
Offshore	Deepwater zone of Lake Ontario.	Submarine cable on lake bottom (115 kV, 180 mm diameter [approx.] 4 km long [approx.]). Clamshell armour at MTO air bubbler.	General construct impacts, temporary disturbance to lake bed – Section 5.5. Operation – Section 5.5.	Section 6.5 and see DFO OS for Underwater Cables (Appendix E).	None Expected.

a see **Figures 2, 4 and 5 (Appendix A)**

b the Project is planning to bury the collector lines unless requested otherwise by the Township; construction method to bury the collector line is not known at the time of report preparation (i.e. drilling vs. open cut)

c assumes all mitigation measures are implemented and successful

Table 4.3: Water Bodies that provide fish habitat where in-water work is required

Reach ID	Fish Habitat Type	
	Direct	Indirect
Northern Drainage		
Station 1 (Access Road to Turbine S06)	X (seasonal)	
Southern Drainage		
Miller Municipal Drain - Stations 52, 38, 34 and 35 (Access Road to Turbine S20)	X	
Station 37/60 (Access Road to Turbine S34)	X (seasonal)	
Lake Ontario		
Island – nearshore area (Dock and Cable Landing)	X	
Mainland – nearshore area (Dock and Cable Landing)	X	

Appendix C:
Correspondence with MOECC

Algonquin Power Co.

2845 Bristol Circle
Oakville, Ontario,
Canada L6H 7H7

Tel: 905.465.4500

Fax: 905.465.4514

May 01, 2015

Mr. Mohsen Keyvani
Director
Environmental Approvals Branch
Ministry of the Environment and Climate Change
2 St. Clair Avenue West, Floor 12A
Toronto, Ontario
M4V 1L5

Attention: Mr. Mohsen Keyvani, Director, Environmental Approvals Branch
Reference: Amherst Island Wind Energy Project ("Project") - Proposed Modifications
MOE reference # 1271-96VNH3

Dear Mr. Mohsen Keyvani;

As you know, Algonquin Power (on behalf of Windlectric Inc.) is developing the Amherst Island Wind Energy Project (the Project), a proposed 75MW wind energy project on Amherst Island, located within Loyalist Township in the County of Lennox and Addington in eastern Ontario. As discussed with your office, Algonquin Power is considering three modifications to the REA application for the Amherst Island Wind Project, each of which are described further below. We are writing to seek confirmation from the MOECC that these changes would be assessed as Technical Changes under the MOECC's Technical Guide to Renewable Energy Approvals.

The three proposed modifications are: (1) a change in turbine model and associated reduction in the number of turbines, (2) a change in collection system routing to avoid the Village of Stella and (3) changes to the road and collection system to avoid some activities on 2nd Concession. In general, these proposed changes will reduce the Project's already minimized impact on the environmental and archaeological and cultural heritage resources. Further detail is set out below regarding why these changes meet the factors for a Technical Change classification outlined in Chapter 10, Section 2.2 of the Technical Guide.

1. *Reducing the number of Wind Turbines by changing Turbine Model (Siemens 2.942 MW and 2.772 MW)*

This modification involves changing the Project's turbines from a combination of Siemens 2.3 MW and 2.221 MW to a combination of Siemens 2.942 MW and 2.772 MW, and thereby reducing the number of turbines from 33 to 26. The new turbines would be physically identical, specifically with a hub height of 99.5 m and rotor diameter of 113 m.

The modification qualifies as a Technical Change because:

- (a) It will decrease the Project Location size by reducing the number of turbine sites from 33 to 26, including through the removal of two turbine locations closest to Stella: S06 and S15.
- (b) It will decrease the overall impact at the noise receptors near the Project Location because the noise profile of the proposed turbines, when combined with the reduction in number of turbines, results in lower sound levels at all receptors.
- (c) It will not require additional archaeological or cultural heritage assessment. Assessments of all 36 current turbine sites has been completed, and the modification does not involve the relocation of any turbine sites. Therefore, there are not expected to be any changes to the previous recommendations or comments received from the Ministry of Tourism, Culture and Sport (MTCS) for further assessment.
- (d) It will not require any additional natural heritage assessment (NHA). As above, the NHA for all 36 current turbine sites has been completed, and the modification does not involve the relocation of any turbine sites. Therefore, there are not expected to be any changes to the previous recommendations or comments received from the Ministry of Natural Resources and Forestry (MNRFF). If anything, MNRFF may reduce its environmental effects monitoring recommendations given the reduced Project footprint.

2. *Collection System Route Change 1 – Avoiding the Village of Stella*

This proposed modification would involve rerouting the collection system to avoid the Village of Stella. In doing so, this modification would remove a significant portion of the existing collection system from S30 entrance along Front Road, including by removing approximately 4 km of road allowance trenching (including through Stella). The modification would also require new collection corridors from S13 to South Shore Rd. and west to S14 entrance, which would consist of approximately 1 km in road allowance and 700 m of in pasture field.

The modification qualifies as a Technical Change because:

- (a) It will decrease the Project Location size by resulting in a net reduction of approx. 2 km of collection system trenching.
- (b) It will require only minimal additional archaeological and cultural heritage assessment. Regarding the new 1 km collection corridor in road allowance, no Stage 2 archaeological

assessment would be required because the area has been previously disturbed. Regarding the new 700 m collection corridor in pasture field, in 2012, Stantec Consulting conducted Stage 2 archaeological field assessments along approximately 600 meters of this corridor. Only the remaining 100 meters of the proposed corridor would need to be completed for a stage 2 archaeological assessment. Nonetheless, given the results of the assessment in this corridor to date, which did not identify any archaeological sites, there are not expected to be any changes to the previous recommendations or comments received from the MTCS for further assessment. Rather, after an addendum to the Stage 2 Archaeological Assessment Report, Heritage Assessment Report and the Protected Properties Assessment Report are filed with MTCS, we expect a re-confirmation letter (or equivalent) will be obtained.

- (c) It will not require any additional NHA given that natural heritage site investigations have previously been completed for the relevant locations. As a result, additional site visits are not required to determine the status and boundary of natural features in the corridors. Based on the existing studies, no new potential effects are anticipated as a result of the modification. Therefore, an addendum to the Natural Heritage Assessment Report will be filed with MNRF and we expect a re-confirmation letter (or equivalent) will be obtained.

3. *Collection System Route Change 2 – Reducing Impacts on 2nd Concession*

This modification would involve the addition of an underground collector line between T16/T23 and T35. The collector line has been incorporated into the design of the access road between T16/23 and T35.

The modification qualifies as a Technical Change because:

- (a) It will decrease the Project Location size by removing approximately 3 km of double circuit trenching on 2nd Concession.
- (b) It will not require additional archaeological or cultural heritage assessment. Assessment for the proposed new route has already been completed as part of the assessment of an access road that would no longer be required with the reduced turbine layout. Therefore, there are not expected to be any changes to the previous recommendations or comments received from the Ministry of Tourism, Culture and Sport (MTCS) for further assessment.
- (c) It will not require any additional natural heritage assessment (NHA). As above, the NHA for the proposed new route has already been completed. Furthermore, no new potential effects are anticipated as a result of this modification. Therefore, there are not expected to be any changes to the previous recommendations or comments received from the MNRF.

In summary, none of the three proposed modifications described above will result in increased negative environmental effects that will or are likely to occur beyond those originally identified, documented and consulted on during the REA process for the original project. The table below summarizes the various components underlying this assessment, which we will confirm with supporting documentation when a formal Project modification request is submitted.

Environmental Component	Potential Negative Environmental Effects	Mitigation Measures	Monitoring Requirements
Natural Environment Components			
Air Quality	No additional negative effect	No additional mitigation required.	No new monitoring required.
Soil Quality	No additional negative effect	No additional mitigation required.	No new monitoring required.
Soil Quantity	No additional negative effect	No additional mitigation required.	No new monitoring required.
Groundwater	No additional negative effect	No additional mitigation required.	No new monitoring required.
Surface Water Quantity	No additional negative effect.	No additional mitigation required.	No new monitoring required.
Surface Water Quality	No additional negative effect.	No additional mitigation required.	No new monitoring required.
Aquatic Habitat and Biota	No additional negative effect.	No additional mitigation required.	No new monitoring required.
Woodlands	No additional negative effect.	No additional mitigation required.	No new monitoring required.
Wetlands	No additional negative effect.	No additional mitigation required.	No new monitoring required.
Wildlife Habitat	No additional negative effect.	No additional mitigation required.	No new monitoring required.
Wildlife	No additional negative effect.	No additional mitigation required.	No new monitoring required.
Socio-Economic Environmental Components			
Noise	Reduction in noise, due to turbine model change.	No additional mitigation required.	No new monitoring required.
Public and Facility Safety	No additional negative effect.	No additional mitigation required.	No new monitoring required.
Change in Visual Landscape	Reduced visual impact, due to fewer turbines.	No additional mitigation required.	No new monitoring required.
Property Values	No additional negative effect.	No additional	No monitoring

Environmental Component	Potential Negative Environmental Effects	Mitigation Measures	Monitoring Requirements
		mitigation required.	required.
Availability of Resources	No additional negative effect.	No additional mitigation required.	No monitoring required.
Recreational Land Use	No additional negative effect.	No additional mitigation required.	No monitoring required.
Infrastructure	No additional negative effect.	No additional mitigation required.	No new monitoring required.
Traffic	Reduced impact on traffic in the Village of Stella, due to fewer construction activities in the area.	No additional mitigation required.	No new monitoring required.
Archaeological and Heritage Resources	Reduction in potential effects to two previously identified Protected Properties due to fewer construction activities in the Village of Stella. Reduction in potential effects to the previously identified Cultural Heritage Landscapes 1 (Village of Stella), due to fewer construction activities in the Village of Stella.	No additional mitigation required.	No new monitoring required.

CONCLUSION

In our view, the proposed modifications described above are properly classified as Technical Changes because they meet the factors set out in Chapter 10, Section 2.2 of the Technical Guide. Most importantly, the proposed modifications will not result in an increase in the negative environmental effects that will or are likely to occur beyond those that were identified, documented and consulted on during the REA process for the original layout. In fact, the proposed modifications will reduce potential effects associated with the Project, especially given the substantial reduction in the number of turbines and the net reduction in length of and disturbance associated with the collection corridors. Therefore, we request confirmation from you that, if submitted as described above, the proposed modifications would be classified as Technical Changes.

If you have any questions or require any further information please do not hesitate to the undersigned at 905-829-6388 or Sean Fairfield at 905-465-4518.

Regards,

Algonquin Power Co.
On behalf of Windlectric Inc.

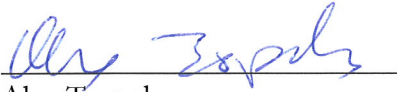
A handwritten signature in blue ink, appearing to read "Alex Tsopelas", is written over a horizontal line.

Alex Tsopelas

Project Manager, Renewables

cc: Sean Fairfield, Algonquin Power Co.

Kerrie Skillen, Stantec Consulting

Appendix D:
Correspondence with MNR

**Ministry of Natural
Resources and Forestry**

Regional Resources Section
Southern Region
Regional Operations Division
300 Water Street
Peterborough, ON K9J 3C7
Tel: 705-755-1328
Fax: 705-755-3233

**Ministère des Richesses
naturelles et des Forêts**

Ressources régionales article
Région du Sud
Division des opérations régionales
300, rue Water
Peterborough (ON) K9J 3C7
Tél: 705-755-1328
Télé: 705-755-3233



January 9, 2015

Sean Fairfield (Sean.Fairfield@algonquinpower.com)
Windlectric Inc.
354 Davis Road
Oakville, ON
L6J 2X1

RE: Modifications to Amherst Island Wind Energy Project, Re-Confirmation

Dear Mr. Fairfield:

The Ministry of Natural Resources and Forestry (MNRF) has received your correspondence dated December 1, 2014 and January 7, 2015 describing project modifications associated with the Amherst Island Wind Energy Project. The following modifications have been made subsequent to MNRF's letter confirming the Natural Heritage Assessment (NHA) in respect of the project:

- Reduction in the number of turbines from 36 to 27 (including removal of S06, S08, S10, S15, S17, S23, S25, S32, S35) and removal of associated collector lines (including along public road allowances) and access roads;
- Addition of underground collector line along previously approved access road between Turbines S16/S23 and Turbine S35;
- Addition of underground collector line along South Shore Road and up to S13;
- Removal of the portions of the proposed underground collector line along the following public road allowances:
 - Stella Forty Foot Rd. from the potential O&M building location north of Second Concession to Front Road;
 - on Front Road through Stella and to S30; also,
 - along all portions of Second Concession Road west of the entrance to S01.

Upon review of these modifications, MNRF is satisfied that the NHA requirements of Ontario Regulation 359/09 have been met. Please add this letter as an addendum to the confirmation letter issued Dec 14, 2012 along with subsequent confirmation letters, for the Amherst Island Wind Energy Project.

If you wish to discuss, please contact Clairissa Myschowoda, Acting Renewable Energy Coordinator, at clairissa.myschowoda@ontario.ca or at 705-755-1362.

Sincerely,

A handwritten signature in black ink, appearing to read "Kazia Millan".

Kazia Millan
Acting Land Use Planning Supervisor
Regional Resources Section, Southern Region

- c. Clairissa Myschowoda, Acting Renewable Energy Coordinator, MNRF
Susanne Edwards, Senior Project Evaluator, MOEEC
Katherine St. James, Stantec Consulting



Stantec Consulting Ltd.
70 Southgate Drive, Suite 1
Guelph ON N1G 4P5
Tel: (519) 836-6050
Fax: (519) 836-2493

December 1, 2014
File: 160960595

Attention: Clairissa Myschowoda

Ontario Ministry of Natural Resources and Forestry
Peterborough District
1st Floor, South Tower
300 Water St
Peterborough ON K9J 8M5

Dear Ms. Mychowoda,

**Reference: Amherst Island Wind Energy
Notification of Technical Project Change**

The purpose of this letter is to provide the Ministry of Natural Resources and Forestry (MNRF) with detail regarding technical updates to the Amherst Island Wind Energy Project (the "Project"). These Project updates have been discussed with the Ministry of the Environment and Climate Change (MOECC), who has verified that the updates are a Technical Change as pursuant to the classification system outlined in the Ministry of the Environment's Technical Guide to Renewable Energy Approvals (October, 2013). Given the nature of these technical updates, they do not require any modifications to the Natural Heritage Assessment and Environmental Impact Study (NHA/EIS). As such, the update is being provided for MNRF's information; a re-confirmation of the NHA/EIS is not required. A separate letter, detailing the collector line to S13 and Zone of Investigation area changes requiring an NHA amendment, was submitted previously.

The technical updates are as follows:

- The reduction in the number of Wind Turbines by changing the Turbine Model (12 2.942 MW turbines and 15 2.772 MW turbines) (see **Figure 1, Attachment 1**); and,
- The addition of an underground collector line along a previously approved access road between T16/T23 and T35 (see **Figure 1, Attachment 1**).

The first update involves changing the Project's turbines from a combination of Siemens 2.3 MW and 2.221 MW to a combination of Siemens 2.942 MW and 2.772 MW, and thereby reducing the number of turbines from 36 to 27. The new turbines would be physically identical, specifically with a hub height of 99.5 m and rotor diameter of 113 m. The modification will decrease the Project Location size by reducing the number of turbine sites from 36 to 27. All of these 27 turbine sites are in previously studied and proposed locations.

The second update would involve the addition of an underground collector line along a previously approved access road between T16/T23 and T35. This underground collector line has been incorporated into the design of the access road between T16/23 and T35.

Because the collector line will use the same corridor as the previously studied and proposed access road, the Project Location will not be changed, and therefore there will be no new features to be considered within 120 m of the Project Location. The addition of the underground



**Reference: Amherst Island Wind Energy
 Notification of Technical Project Change**

collector line route provides Windlectric Inc. with greater design flexibility. The construction and installation activities for this underground collector line will be completed in the same manner (using the same mitigation measures) as the collector lines which are described in the Construction Plan Report, submitted as part of the Renewable Energy Application (REA).

Changes to Assessment of Impacts

The removal of these turbines and their associated access roads and underground cabling will not expand the Project Location into new areas, but will reduce the overall size of the Project Location. As a result, a number of significant features will no longer be within the 120 m Zone of Investigation. Specifically, the following features are no longer within 120 m of the Project Location:

- Wetlands 3 and 12;
- Woodlands 1, 2 and 32;
- Raptor Winter Area RWA-1;
- Old-Growth Forest OGF2; and,
- Open Country Bird Breeding OCB-1.

As identified in the Natural Heritage Assessment Report, these significant features were not anticipated to be negatively affected by the Project in any event. As such, mitigation measures, as outlined in Tables 14B, 15B and 16B of the NHA/EIS will not be required for these features as a result of the removal of turbines and related infrastructure. The Project changes have also resulted in an increased distance between some significant features and the Project Location. **Table 1** below summarizes the revised distance calculations. These significant habitat features are shown on **Figure 2, Attachment 1**.

Table 1: Summary of Changes to Significant Natural Features				
Feature ID	Feature Type	Old Distance to Project Infrastructure Within 120 m (m)	New Distance to Project Infrastructure Within 120 m (m)	Significant? (Y/N)
Wetlands				
4	Wetland	WT-76 UL-14 AR-45 TC-39	WT-76 UL-41 AR-38 TC-39	Yes
9	Wetland	WT-68 UL-18 AR-99	UL-18 AR-99	Yes



Reference: Amherst Island Wind Energy
 Notification of Technical Project Change

Table 1: Summary of Changes to Significant Natural Features				
Feature ID	Feature Type	Old Distance to Project Infrastructure Within 120 m (m)	New Distance to Project Infrastructure Within 120 m (m)	Significant? (Y/N)
		TC-61		
10 (PSW)	Wetland – Nut Island Duck Club Marsh	WT-3 UL-13 AR-74 TC-3	UL-13 AR-74 TC-96	Yes
13	Wetland	UL-1 AR-100	UL-95 AR-100	Yes
16	Wetland	UL-19 AR-10	UL-19	Yes
Woodlands				
4	Woodland	WT-48 UL-overlapping AR-3 TC-23	WT-72 UL-overlapping AR-3 TC-63	Yes
Seasonal Concentration Areas				
RWA-4	Raptor Wintering Area	WT – overlapping AR – overlapping UL – overlapping TC – overlapping BU – overlapping	WT – 84 AR – overlapping UL – overlapping TC – 47 BU – overlapping	Yes
ML1	Landbird Migratory Stopover Areas	WT – 48 UL – 3 AR – 3 TC – 23	WT – 72 UL – 3 AR – 3 TC – 47	Yes
Habitat for Species of Conservation Concern				
ABB1	Woodland Area-Sensitive Breeding Bird Habitat	WT – 48 UL – 3 AR – 3 TC – 23	WT – 72 UL – 3 AR – 3 TC – 63	Yes
OCB-4	Open Country Bird Breeding Habitat	WT – overlapping AR – overlapping UL – overlapping TC – overlapping	WT – 84 AR – overlapping UL – overlapping TC – 47	Yes



Reference: **Amherst Island Wind Energy
Notification of Technical Project Change**

Table 1: Summary of Changes to Significant Natural Features

Feature ID	Feature Type	Old Distance to Project Infrastructure Within 120 m (m)	New Distance to Project Infrastructure Within 120 m (m)	Significant? (Y/N)
		BU – overlapping	BU – overlapping	
SSB1	Shrub/Early Successional Bird Breeding Habitat	UL – 20 AR – 16	UL – 82 AR – 86	Yes

Legend: WT: Wind Turbine; UL: Underground Transmission Line; AR: Access Road, OL: Overhead Transmission Line, TC: Temporary Construction Areas, BU: Building/Substation

Mitigation measures as outlined in Tables 14B, 15B and 16B of the NHA/EIS will continue to be required, as applicable, for features listed in **Table 1**.

Furthermore, the removal of the turbines and associated components reduces the total amount of Open Country Breeding Bird/Short-eared Owl habitat removal from 17.2 ha to 11.6 ha permanently (0.6% to 0.4% of the total habitat area identified – 3113 ha) and from 67.8 ha to 41.6 ha temporarily (2.1% to 1.3% of the total habitat area identified). These significant habitat features are shown on **Figure 3, Attachment 1**.

The removal of the turbines and associated components also reduces the total amount of Raptor Wintering Area habitat removal from 17.7 ha to 12.2 ha permanently (0.5% to 0.3% of the total habitat area identified – 3742 ha) and from 68.6 ha to 42.3 ha temporarily (1.8% to 1.1% of the total habitat area identified). These significant habitat features are shown on **Figure 3, Attachment 1**.

Changes to the Environmental Effects Monitoring Plan

The Project change will result in minor changes to the Environmental Effects Monitoring Plan (EEMP). Raptor Wintering Area RWA-1 and Open Country Bird Breeding OCB-1 are no longer within 120 m of the Project Location. As such, post-construction monitoring requirements in the EEMP are no longer required for these features.

Post-construction mortality monitoring is required at 30% of turbines, to a minimum of 10 turbines. As such, regardless of the reduction in the number of turbines, the current requirement in the EEMP to conduct mortality monitoring at 10 turbines will remain unchanged, although the 10 turbines chosen to be included in this mortality monitoring must change based on the removal of turbines in this technical Project update.

The proposed subset of turbines to be included in the post-construction monitoring, as indicated on Figure 2 of the EEMP, will be revised to accommodate the removal of some turbines in the



November 14, 2014
Clairissa Myschowoda
Page 5 of 5

**Reference: Amherst Island Wind Energy
Notification of Technical Project Change**

subset. The final subset of turbines to be included in the post-construction monitoring will be determined in consultation with the MNR prior to the beginning of the monitoring program.

All other commitments within the EEMP for post-construction monitoring, mitigation and contingency measures remain unchanged.

CLOSING

Stantec Consulting Ltd. prepared this letter report for Windlectric Inc. for the Amherst Island Wind Energy Project. Windlectric Inc. is committed to implementing the appropriate protection and mitigation measures as they apply to the construction and operation of the proposed Project.

Regards,

STANTEC CONSULTING LTD.

Katherine St. James, M.Sc.
Terrestrial Ecologist
Phone: (519) 836-6050
Fax: (519) 836-2493
Katherine.stjames@stantec.com

c. Alex Tsopelas, Algonquin Power Co.
Sean Fairfield, Algonquin Power Co.
Kerrie Skillen, Stantec Consulting Ltd.

Attachments:

Attachment 1: Updates to NHA Figures

ks \\cd1220-f02\root\work_group\01609\active\60960595\reports\03_modification reports\rep_modification_no. 3_draft\mnr letters\turbine removal letter\ltr_60595_aiwip-technical_update_20141201_final.docx

Attachment 1

Updates to NHA Figures

Legend

- Study Area
- 120m Zone of Investigation
- Project Components**
- Turbine (No Changes Proposed)
- Turbine (Removed)
- Met Tower - Potential Location (No Changes Proposed)
- Met Tower - Potential Location (Removed)
- Substation (Potential Location)
- Access Road (No Changes Proposed)
- Access Road (Removed)
- Collector Line (Removed)
- Collector Line (New) - within previously approved access road
- Collector Line (Additional Project Design Change Modification)
- Collector Line (No Proposed Changes)
- Submarine Cable Path
- Laydown Area and Crane Pad (No Changes Proposed)
- Laydown Area and Crane Pad (Removed)
- Turbine Blade Tip (No Changes Proposed)
- Turbine Blade Tip (Removed)
- Operation and Maintenance Building (Potential Location)
- Potential Culvert Location
- Point of Common Coupling
- Mainland Cable Vault (Potential Location)
- Island Cable Vault
- Aboveground Storage Tanks (Potential Location)
- Constructible Area (No Proposed Changes)
- Constructible Area (Removed)
- Mainland Dock (Potential Location)
- Island Dock
- Batch Plant (Potential Location)
- Site Office (Potential Location)
- Storage Shed
- Transmission Lines**
- Mainland Option 1
- Mainland Option 2
- Island Transmission Line
- Land Use**
- Central Staging Area
- Switching Station (Potential Location)
- Existing Features**
- Road
- Unopened Road Allowance
- Railway
- Hydro Line
- Watercourse
- Waterbody
- Wooded Area
- Property Line

Notes

1. Coordinate System: NAD 1983 UTM Zone 18N
2. Base features produced under license with the Ontario Ministry of Natural Resources © Queen's Printer for Ontario, 2014.

November 2014
160960595

Client/Project

Windlectric Inc.
Amherst Island Wind Energy Project

Figure No.

1.0

DRAFT

Title

Project Location - Modification #3:
Overview

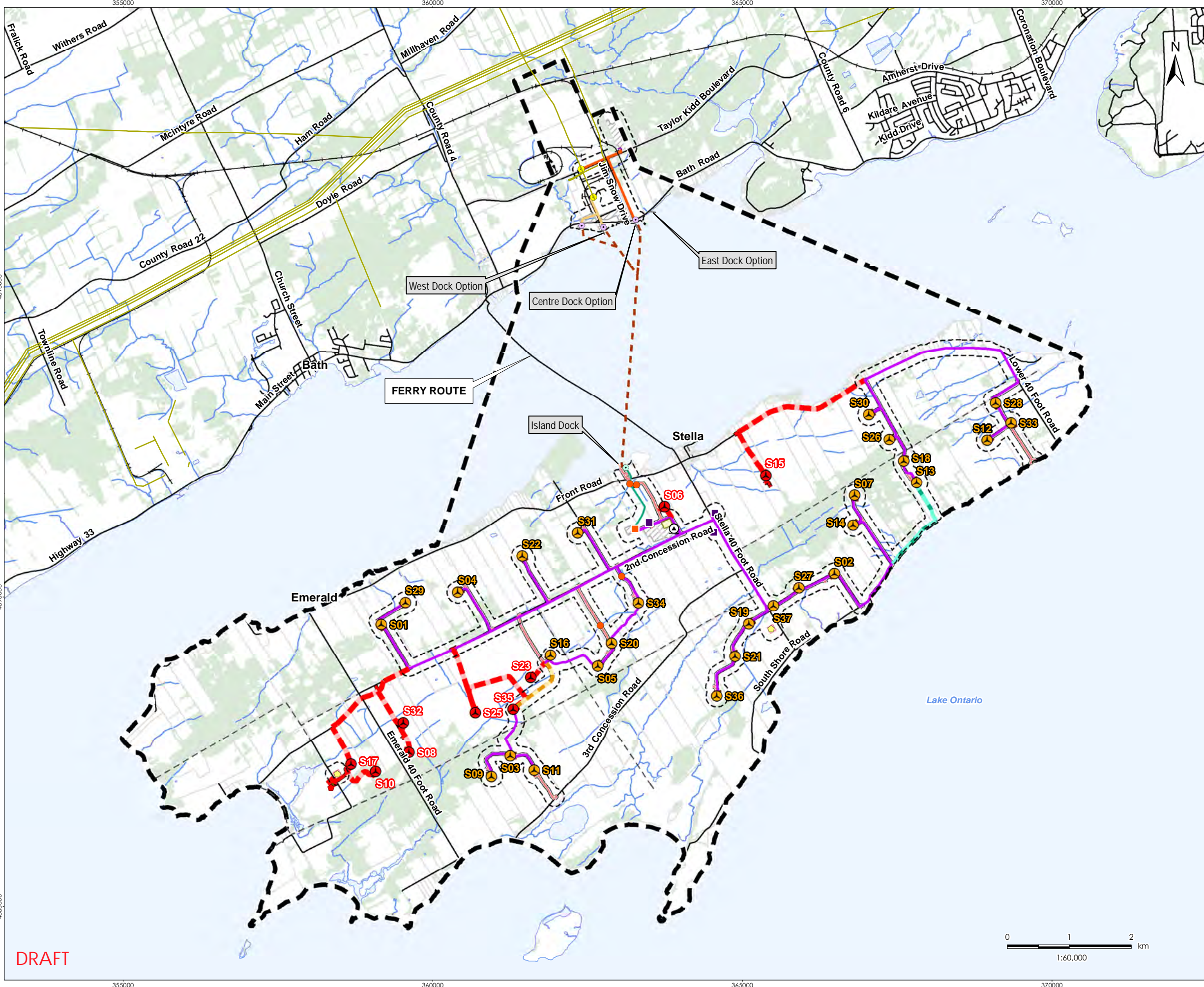

DRAFT

\\C:\1220-102\work_group\01609\active\60960595\drawing\MXD\Terrestrial\Agency\Notice_to_MNRE_Nov2014\160960595_Fig1_ProjectLocation_Overview_20141127.mxd
 Revised: 2014-11-27 By: p.worsell
 4885000

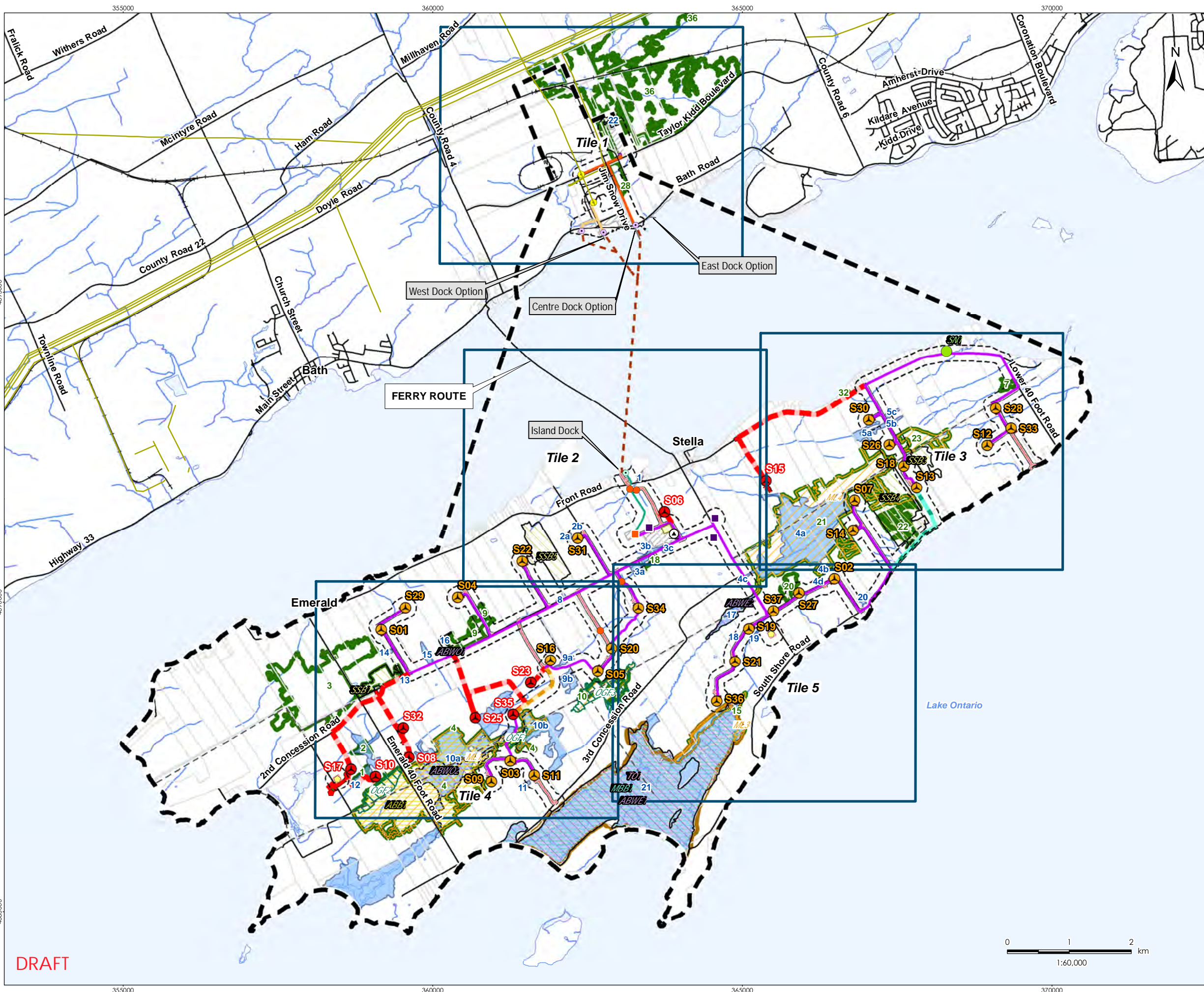

- ### Legend
- Study Area
 - 120m Zone of Investigation
 - Project Components
 - Turbine (No Changes Proposed)
 - Turbine (Removed)
 - Met Tower - Potential Location (No Changes Proposed)
 - Met Tower - Potential Location (Removed)
 - Substation (Potential Location)
 - Access Road (No Changes Proposed)
 - Access Road (Removed)
 - Collector Line (Removed)
 - Collector Line (New) - within previously approved access road
 - Collector Line (Additional Project Design Change Modification)
 - Collector Line (No Proposed Changes)
 - Submarine Cable Path
 - Laydown Area and Crane Pad (No Changes Proposed)
 - Laydown Area and Crane Pad (Removed)
 - Turbine Blade Tip (No Changes Proposed)
 - Turbine Blade Tip (Removed)
 - Operation and Maintenance Building (Potential Location)
 - Potential Culvert Location
 - Point of Common Coupling
 - Mainland Cable Vault (Potential Location)
 - Island Cable Vault
 - Aboveground Storage Tanks (Potential Location)
 - Constructible Area (No Proposed Changes)
 - Constructible Area (Removed)
 - Mainland Dock (Potential Location)
 - Island Dock
 - Batch Plant (Potential Location)
 - Site Office (Potential Location)
 - Storage Shed
 - Transmission Lines
 - Mainland Option 1
 - Mainland Option 2
 - Island Transmission Line
 - Land Use
 - Central Staging Area
 - Switching Station (Potential Location)
 - Existing Features
 - Road
 - Unopened Road Allowance
 - Railway
 - Hydro Line
 - Watercourse
 - Waterbody
 - Amherst Bay Life Science ANSI
 - Property Line
 - Significant Wildlife Habitat Features
 - Snake Hibernacula (SN)
 - Amphibian Breeding (ABWO & ABWE)
 - Area-Sensitive Breeding Bird (ABB)
 - Marsh Breeding Bird (MBB)
 - Shrub/Early Successional Bird Breeding (SSB)
 - Turtle Overwintering (TO)
 - Landbird Migratory Stopover Area (ML)
 - Waterfowl Stopover & Staging - Terrestrial (WT)
 - Old Growth Forest (OGF)
 - Significant Woodland
 - Significant Wetland

Notes

- Coordinate System: NAD 1983 UTM Zone 18N
- Base features produced under license with the Ontario Ministry of Natural Resources © Queen's Printer for Ontario, 2014.

November 2014
160960595

Client/Project
Windlectric Inc.
Amherst Island Wind Energy Project

Figure No.
2.0 **DRAFT**

Title
Significant Natural Features &
Wildlife Habitat - Overview

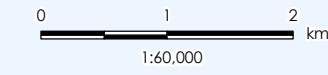

DRAFT

\\C:\1220-102\work_group\01609\active\60960595\drawing\MXD\Terrestrial\Agency\Notice_to_MNRE_Nov2014\160960595_Fig2_SignificantWildlifeHabitat_Overview_20141127.mxd
 Revised: 2014-11-27 By: pwnorell
 4885000

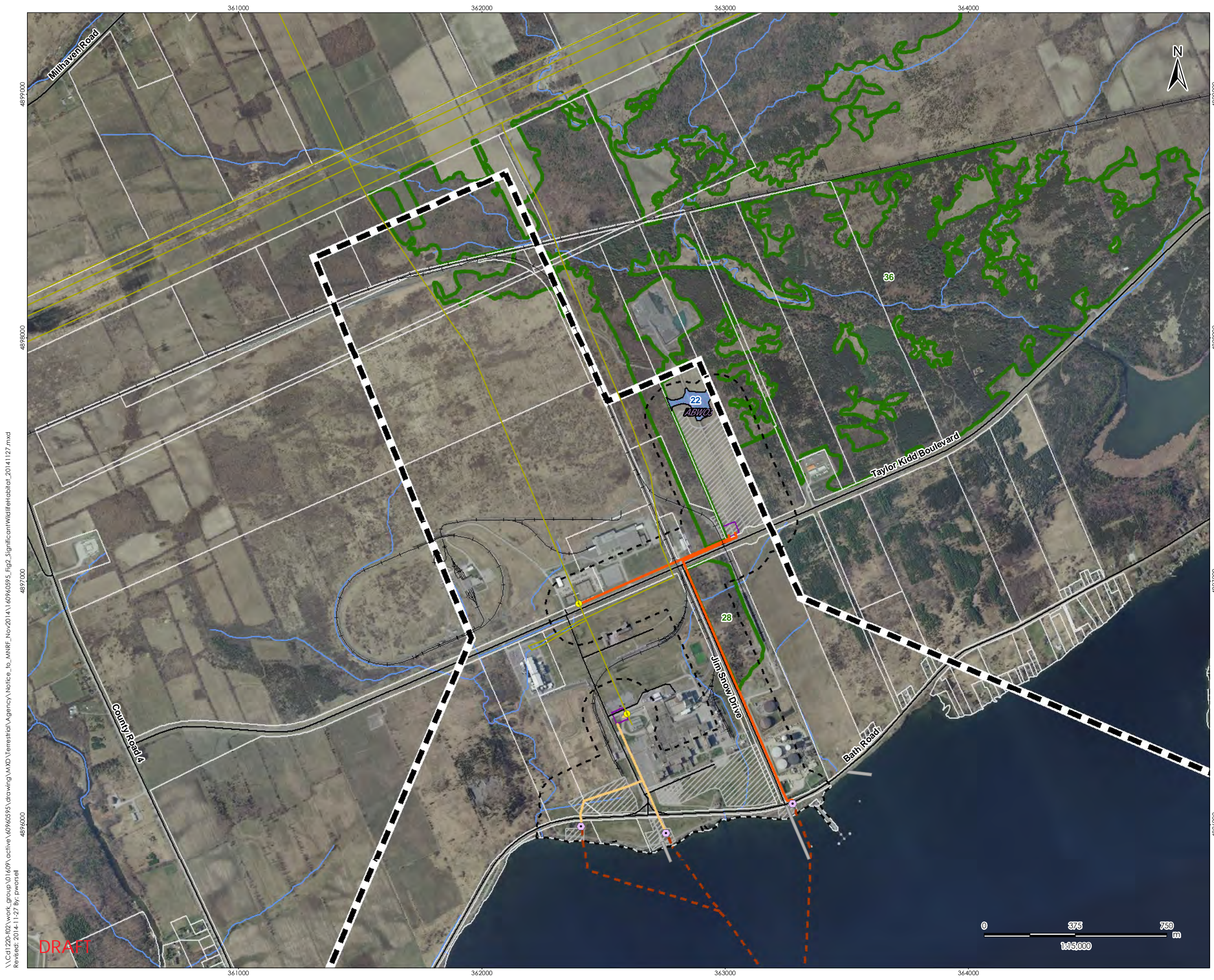

- Legend**
- Study Area
 - 120m Zone of Investigation
 - Project Components
 - Turbine (No Changes Proposed)
 - Turbine (Removed)
 - Met Tower - Potential Location (No Changes Proposed)
 - Met Tower - Potential Location (Removed)
 - Access Road (No Changes Proposed)
 - Access Road (Removed)
 - Collector Line (Removed)
 - Collector Line (New) - within previously approved access road
 - Collector Line (Additional Project Design Change Modification)
 - Collector Line (No Proposed Changes)
 - Submarine Cable Path
 - Laydown Area and Crane Pad (No Changes Proposed)
 - Laydown Area and Crane Pad (Removed)
 - Operation and Maintenance Building (Potential Location)
 - Turbine Blade Tip (No Changes Proposed)
 - Turbine Blade Tip (Removed)
 - Substation (Potential Location)
 - Potential Culvert Location
 - Point of Common Coupling
 - Mainland Cable Vault (Potential Location)
 - Island Cable Vault
 - Aboveground Storage Tanks (Potential Location)
 - Constructible Area (No Proposed Changes)
 - Constructible Area (Removed)
 - Mainland Dock (Potential Location)
 - Island Dock
 - Batch Plant (Potential Location)
 - Site Office (Potential Location)
 - Storage Shed
 - Transmission Lines
 - Mainland Option 1
 - Mainland Option 2
 - Island Transmission Line
 - Land Use
 - Central Staging Area
 - Switching Station (Potential Location)
 - Existing Features
 - Road
 - Unopened Road Allowance
 - Railway
 - Hydro Line
 - Watercourse
 - Amherst Bay Life Science ANSI
 - Property Line
 - Significant Wildlife Habitat Features
 - Snake Hibernacula (SN)
 - Amphibian Breeding (ABWO & ABWE)
 - Area-Sensitive Breeding Bird (ABB)
 - Marsh Breeding Bird (MBB)
 - Shrub/Early Successional Bird Breeding (SSB)
 - Turtle Overwintering (TO)
 - Shorebird Migratory Stopover (SM)
 - Landbird Migratory Stopover Area (ML)
 - Waterfowl Stopover & Staging - Terrestrial (WT)
 - Old Growth Forest (OGF)
 - Significant Woodland
 - Significant Wetland

Notes

- Coordinate System: NAD 1983 UTM Zone 18N
- Base features produced under license with the Ontario Ministry of Natural Resources © Queen's Printer for Ontario, 2014.
- Orthoimagery © First Base Solutions, 2014. Imagery taken in 2008.

November 2014
160960595

Client/Project
Windlectric Inc.
Amherst Island Wind Energy Project

Figure No.
2.1 **DRAFT**

Title
Significant Natural Features & Wildlife Habitat

\\C:\1220-102\work_group\01609\active\60960595\drawing\MXD\Terrestrial\Agency\Notice_to_MNRE_Nov2014\160960595_Fig2_SignificantWildlifeHabitat_20141127.mxd
 Revised: 2014-11-27 By: p.worsell

DRAFT

361000 362000 363000 364000 365000

4894000 4893000 4892000 4891000



Legend

- Study Area
- 120m Zone of Investigation
- Project Components
 - Turbine (No Changes Proposed)
 - Turbine (Removed)
 - Met Tower - Potential Location (No Changes Proposed)
 - Met Tower - Potential Location (Removed)
 - Access Road (No Changes Proposed)
 - Access Road (Removed)
 - Collector Line (Removed)
 - Collector Line (New) - within previously approved access road
 - Collector Line (Additional Project Design Change Modification)
 - Collector Line (No Proposed Changes)
 - Submarine Cable Path
 - Laydown Area and Crane Pad (No Changes Proposed)
 - Laydown Area and Crane Pad (Removed)
 - Operation and Maintenance Building (Potential Location)
 - Turbine Blade Tip (No Changes Proposed)
 - Turbine Blade Tip (Removed)
 - Substation (Potential Location)
 - Potential Culvert Location
 - Point of Common Coupling
 - Mainland Cable Vault (Potential Location)
 - Island Cable Vault
 - Aboveground Storage Tanks (Potential Location)
 - Constructible Area (No Proposed Changes)
 - Constructible Area (Removed)
 - Mainland Dock (Potential Location)
 - Island Dock
 - Batch Plant (Potential Location)
 - Site Office (Potential Location)
 - Storage Shed
- Transmission Lines
 - Mainland Option 1
 - Mainland Option 2
 - Island Transmission Line
- Land Use
 - Central Staging Area
 - Switching Station (Potential Location)
- Existing Features
 - Road
 - Unopened Road Allowance
 - Railway
 - Hydro Line
 - Watercourse
 - Amherst Bay Life Science ANSI
 - Property Line
- Significant Wildlife Habitat Features
 - Snake Hibernacula (SN)
 - Amphibian Breeding (ABWO & ABWE)
 - Area-Sensitive Breeding Bird (ABB)
 - Marsh Breeding Bird (MBB)
 - Shrub/Early Successional Bird Breeding (SSB)
 - Turtle Overwintering (TO)
 - Shorebird Migratory Stopover (SM)
 - Landbird Migratory Stopover Area (ML)
 - Waterfowl Stopover & Staging - Terrestrial (WT)
 - Old Growth Forest (OGF)
 - Significant Woodland
 - Significant Wetland

Notes

- Coordinate System: NAD 1983 UTM Zone 18N
- Base features produced under license with the Ontario Ministry of Natural Resources © Queen's Printer for Ontario, 2014.
- Orthoimagery © First Base Solutions, 2014. Imagery taken in 2008.

November 2014
160960595

Client/Project

Windlectric Inc.
Amherst Island Wind Energy Project

Figure No.
2.2

DRAFT

Title

Significant Natural Features &
Wildlife Habitat



DRAFT



\\C:\1220-102\work_group\01609\active\60960595\agency\Notice_to_MNRE_Nov2014\160960595_Fig2_SignificantWildlifeHabitat_20141127.mxd
Revised: 2014-11-27 By: p.worsell

\\C:\1220-102\work_group\01609\active\60960595\drawing\AMD\Terrestrial\Agency\Notice_to_MNRE_Nov2014\160960595_Fig2_SignificantWildlifeHabitat_20141127.mxd
Revised: 2014-11-27 By: p.worsell

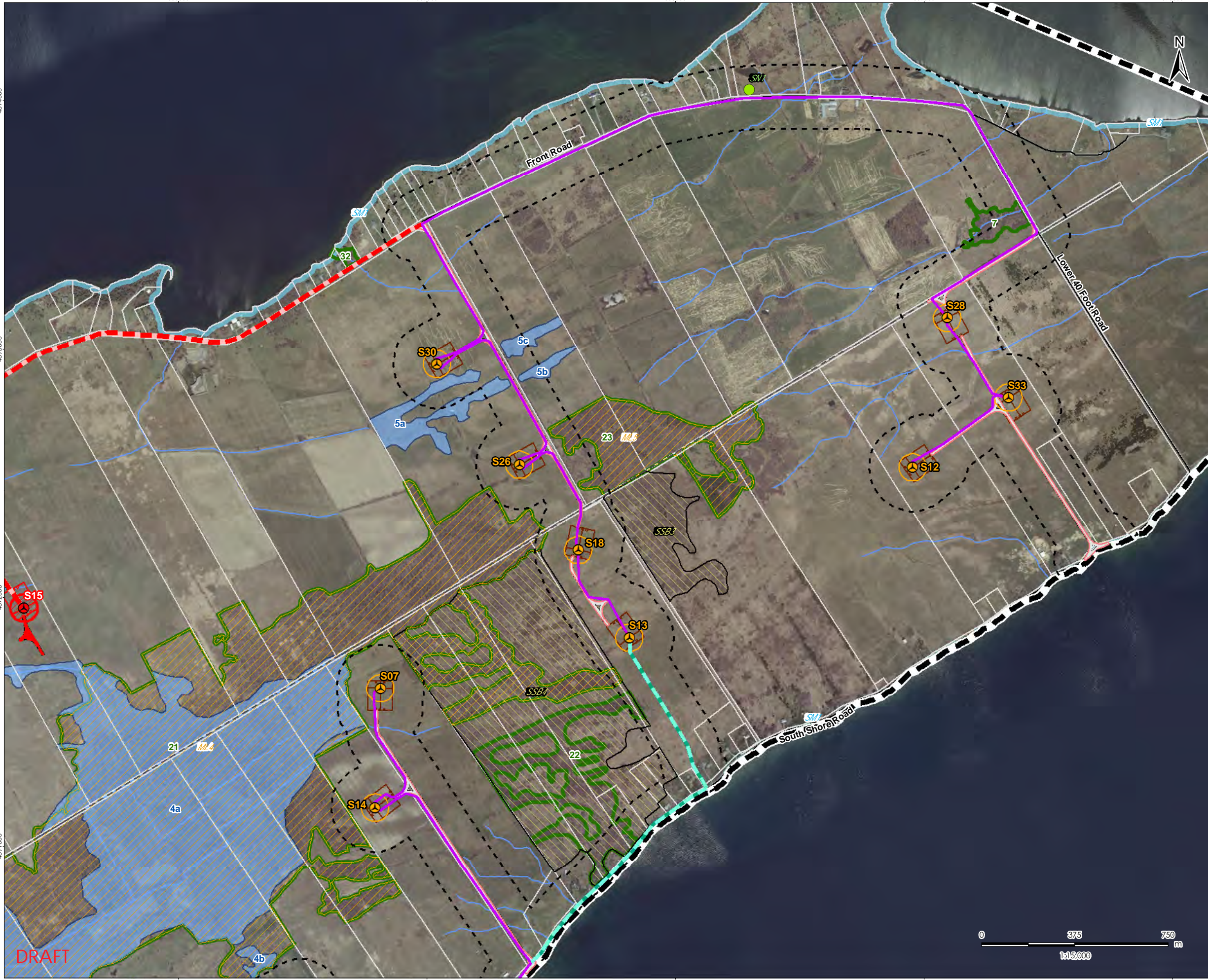

- Legend**
- Study Area
 - 120m Zone of Investigation
 - Project Components
 - Turbine (No Changes Proposed)
 - Turbine (Removed)
 - Met Tower - Potential Location (No Changes Proposed)
 - Met Tower - Potential Location (Removed)
 - Access Road (No Changes Proposed)
 - Access Road (Removed)
 - Collector Line (Removed)
 - Collector Line (New) - within previously approved access road
 - Collector Line (Additional Project Design Change Modification)
 - Collector Line (No Proposed Changes)
 - Submarine Cable Path
 - Laydown Area and Crane Pad (No Changes Proposed)
 - Laydown Area and Crane Pad (Removed)
 - Operation and Maintenance Building (Potential Location)
 - Turbine Blade Tip (No Changes Proposed)
 - Turbine Blade Tip (Removed)
 - Substation (Potential Location)
 - Potential Culvert Location
 - Point of Common Coupling
 - Mainland Cable Vault (Potential Location)
 - Island Cable Vault
 - Aboveground Storage Tanks (Potential Location)
 - Constructible Area (No Proposed Changes)
 - Constructible Area (Removed)
 - Mainland Dock (Potential Location)
 - Island Dock
 - Batch Plant (Potential Location)
 - Site Office (Potential Location)
 - Storage Shed
 - Transmission Lines
 - Mainland Option 1
 - Mainland Option 2
 - Island Transmission Line
 - Land Use
 - Central Staging Area
 - Switching Station (Potential Location)
 - Existing Features
 - Road
 - Unopened Road Allowance
 - Railway
 - Hydro Line
 - Watercourse
 - Amherst Bay Life Science ANSI
 - Property Line
 - Significant Wildlife Habitat Features
 - Snake Hibernacula (SN)
 - Amphibian Breeding (ABWO & ABWE)
 - Area-Sensitive Breeding Bird (ABB)
 - Marsh Breeding Bird (MBB)
 - Shrub/Early Successional Bird Breeding (SSB)
 - Turtle Overwintering (TO)
 - Shorebird Migratory Stopover (SM)
 - Landbird Migratory Stopover Area (ML)
 - Waterfowl Stopover & Staging - Terrestrial (WT)
 - Old Growth Forest (OGF)
 - Significant Woodland
 - Significant Wetland

Notes

- Coordinate System: NAD 1983 UTM Zone 18N
- Base features produced under license with the Ontario Ministry of Natural Resources © Queen's Printer for Ontario, 2014.
- Orthoimagery © First Base Solutions, 2014. Imagery taken in 2008.

November 2014
160960595

Client/Project
Windlectric Inc.
Amherst Island Wind Energy Project

Figure No.
2.3 **DRAFT**

Title
Significant Natural Features &
Wildlife Habitat



DRAFT

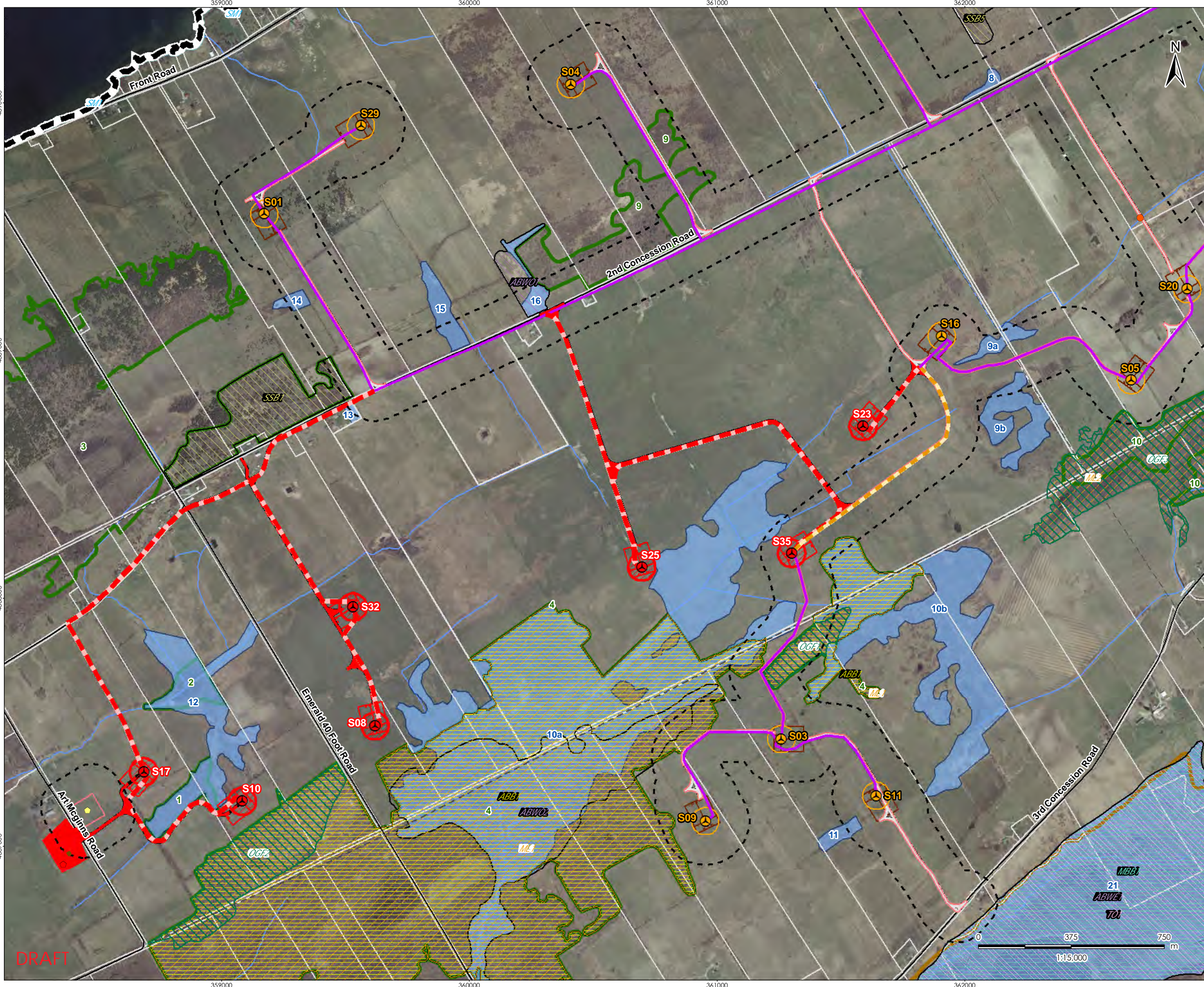

- Legend**
- Study Area
 - 120m Zone of Investigation
 - Project Components
 - Turbine (No Changes Proposed)
 - Turbine (Removed)
 - Met Tower - Potential Location (No Changes Proposed)
 - Met Tower - Potential Location (Removed)
 - Access Road (No Changes Proposed)
 - Access Road (Removed)
 - Collector Line (Removed)
 - Collector Line (New) - within previously approved access road
 - Collector Line (Additional Project Design Change Modification)
 - Collector Line (No Proposed Changes)
 - Submarine Cable Path
 - Laydown Area and Crane Pad (No Changes Proposed)
 - Laydown Area and Crane Pad (Removed)
 - Operation and Maintenance Building (Potential Location)
 - Turbine Blade Tip (No Changes Proposed)
 - Turbine Blade Tip (Removed)
 - Substation (Potential Location)
 - Potential Culvert Location
 - Point of Common Coupling
 - Mainland Cable Vault (Potential Location)
 - Island Cable Vault
 - Aboveground Storage Tanks (Potential Location)
 - Constructible Area (No Proposed Changes)
 - Constructible Area (Removed)
 - Mainland Dock (Potential Location)
 - Island Dock
 - Batch Plant (Potential Location)
 - Site Office (Potential Location)
 - Storage Shed
 - Transmission Lines
 - Mainland Option 1
 - Mainland Option 2
 - Island Transmission Line
 - Land Use
 - Central Staging Area
 - Switching Station (Potential Location)
 - Existing Features
 - Road
 - Unopened Road Allowance
 - Railway
 - Hydro Line
 - Watercourse
 - Amherst Bay Life Science ANSI
 - Property Line
 - Significant Wildlife Habitat Features
 - Snake Hibernacula (SN)
 - Amphibian Breeding (ABWO & ABWE)
 - Area-Sensitive Breeding Bird (ABB)
 - Marsh Breeding Bird (MBB)
 - Shrub/Early Successional Bird Breeding (SSB)
 - Turtle Overwintering (TO)
 - Shorebird Migratory Stopover (SM)
 - Landbird Migratory Stopover Area (ML)
 - Waterfowl Stopover & Staging - Terrestrial (WT)
 - Old Growth Forest (OGF)
 - Significant Woodland
 - Significant Wetland

Notes

- Coordinate System: NAD 1983 UTM Zone 18N
- Base features produced under license with the Ontario Ministry of Natural Resources © Queen's Printer for Ontario, 2014.
- Orthoimagery © First Base Solutions, 2014. Imagery taken in 2008.

November 2014
160960595

Client/Project
Windlectric Inc.
Amherst Island Wind Energy Project

Figure No.
2.4 **DRAFT**

Title
Significant Natural Features & Wildlife Habitat

\\C:\1220-102\work_group\01609\active\60960595\drawing\MXD\Terrestrial\Agency\Notice_to_MNRE_Nov2014\160960595_Fig2_SignificantWildlifeHabitat_20141127.mxd
 Revised: 2014-11-27 By: pwnsell

DRAFT

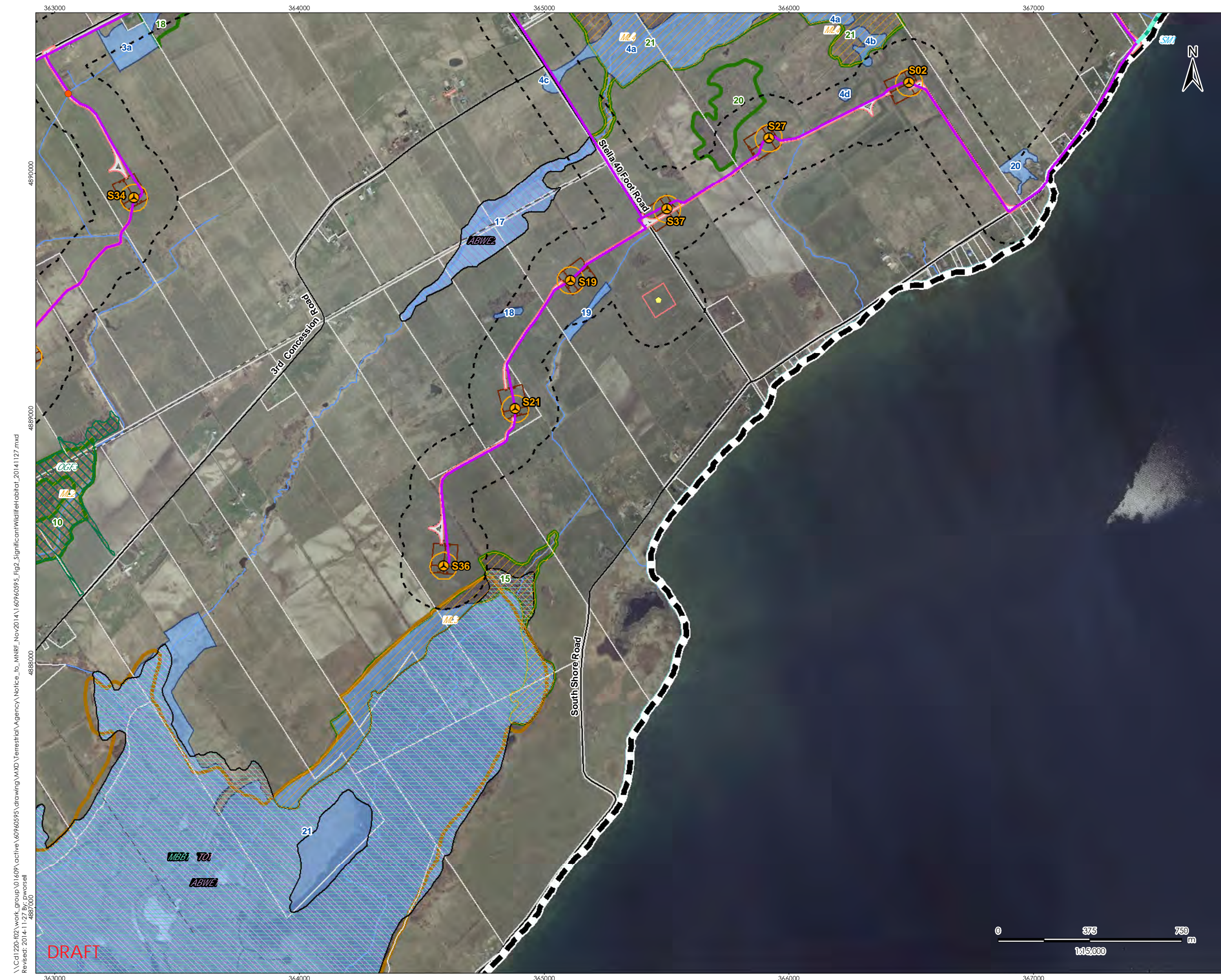

- Legend**
- Study Area
 - 120m Zone of Investigation
 - Project Components**
 - Turbine (No Changes Proposed)
 - Turbine (Removed)
 - Met Tower - Potential Location (No Changes Proposed)
 - Met Tower - Potential Location (Removed)
 - Access Road (No Changes Proposed)
 - Access Road (Removed)
 - Collector Line (Removed)
 - Collector Line (New) - within previously approved access road
 - Collector Line (Additional Project Design Change Modification)
 - Collector Line (No Proposed Changes)
 - Submarine Cable Path
 - Laydown Area and Crane Pad (No Changes Proposed)
 - Laydown Area and Crane Pad (Removed)
 - Operation and Maintenance Building (Potential Location)
 - Turbine Blade Tip (No Changes Proposed)
 - Turbine Blade Tip (Removed)
 - Substation (Potential Location)
 - Potential Culvert Location
 - Point of Common Coupling
 - Mainland Cable Vault (Potential Location)
 - Island Cable Vault
 - Aboveground Storage Tanks (Potential Location)
 - Constructible Area (No Proposed Changes)
 - Constructible Area (Removed)
 - Mainland Dock (Potential Location)
 - Island Dock
 - Batch Plant (Potential Location)
 - Site Office (Potential Location)
 - Storage Shed
 - Transmission Lines**
 - Mainland Option 1
 - Mainland Option 2
 - Island Transmission Line
 - Land Use**
 - Central Staging Area
 - Switching Station (Potential Location)
 - Existing Features**
 - Road
 - Unopened Road Allowance
 - Railway
 - Hydro Line
 - Watercourse
 - Amherst Bay Life Science ANSI
 - Property Line
 - Significant Wildlife Habitat Features**
 - Snake Hibernacula (SN)
 - Amphibian Breeding (ABWO & ABWE)
 - Area-Sensitive Breeding Bird (ABB)
 - Marsh Breeding Bird (MBB)
 - Shrub/Early Successional Bird Breeding (SSB)
 - Turtle Overwintering (TO)
 - Shorebird Migratory Stopover (SM)
 - Landbird Migratory Stopover Area (ML)
 - Waterfowl Stopover & Staging - Terrestrial (WT)
 - Old Growth Forest (OGF)
 - Significant Woodland
 - Significant Wetland

Notes

- Coordinate System: NAD 1983 UTM Zone 18N
- Base features produced under license with the Ontario Ministry of Natural Resources © Queen's Printer for Ontario, 2014.
- Orthoimagery © First Base Solutions, 2014. Imagery taken in 2008.

November 2014
160960595

Client/Project
Windlectric Inc.
Amherst Island Wind Energy Project

Figure No.
2.5 **DRAFT**

Title
Significant Natural Features & Wildlife Habitat



\\C:\1220-102\work_group\01609\active\60960595\drawing\MXD\Terrestrial\Agency\Notice_to_MNRE_Nov2014\160960595_Fig2_SignificantWildlifeHabitat_20141127.mxd
 Revised: 2014-11-27 By: pwnorsell
 4887000

DRAFT

Legend

- Study Area
- 120m Zone of Investigation
- Project Components
 - Turbine (No Changes Proposed)
 - Turbine (Removed)
 - Met Tower - Potential Location (No Changes Proposed)
 - Met Tower - Potential Location (Removed)
 - Substation (Potential Location)
 - Access Road (No Changes Proposed)
 - Access Road (Removed)
 - Collector Line (Removed)
 - Collector Line (New) - within previously approved access road
 - Collector Line (Additional Project Design Change Modification)
 - Collector Line (No Proposed Changes)
 - Submarine Cable Path
 - Laydown Area and Crane Pad (No Changes Proposed)
 - Laydown Area and Crane Pad (Removed)
 - Turbine Blade Tip (No Changes Proposed)
 - Turbine Blade Tip (Removed)
 - Operation and Maintenance Building (Potential Location)
 - Potential Culvert Location
 - Point of Common Coupling
 - Mainland Cable Vault (Potential Location)
 - Island Cable Vault
 - Aboveground Storage Tanks (Potential Location)
 - Constructible Area (No Proposed Changes)
 - Constructible Area (Removed)
 - Mainland Dock (Potential Location)
 - Island Dock
 - Batch Plant (Potential Location)
 - Site Office (Potential Location)
 - Storage Shed
 - Transmission Lines
 - Mainland Option 1
 - Mainland Option 2
 - Island Transmission Line
 - Land Use
 - Central Staging Area
 - Switching Station (Potential Location)
 - Existing Features
 - Road
 - Unopened Road Allowance
 - Railway
 - Hydro Line
 - Watercourse
 - Waterbody
 - Property Line
 - Open Country Breeding Bird Area (OCB) (OCB habitats are transparent with hatching)
 - Raptor Wintering Area (RWA)

Notes

1. Coordinate System: NAD 1983 UTM Zone 18N
2. Base features produced under license with the Ontario Ministry of Natural Resources © Queen's Printer for Ontario, 2014.

November 2014
160960595

Client/Project

Windlectric Inc.
Amherst Island Wind Energy Project

Figure No.
3.0

DRAFT

Title

Significant Open Country Breeding Bird & Raptor Wintering Areas - Overview

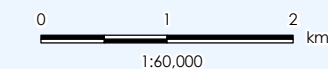
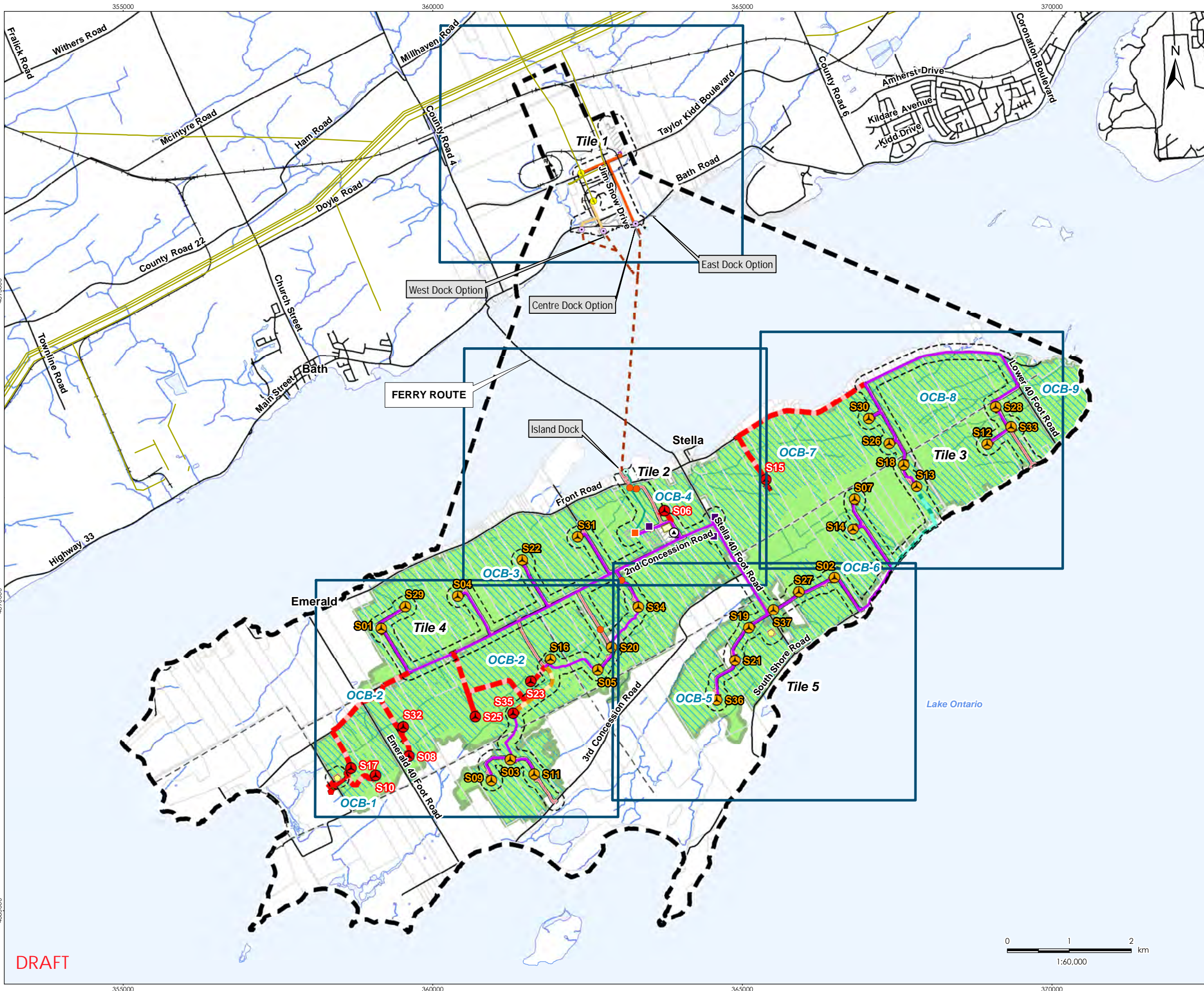

DRAFT

\\C:\1220-102\work_group\01609\active\60960595\drawing\MXD\Terrestrial\Agency\Notice_to_MNRE_Nov2014\160960595_Fig3_SignificantRWA_OCB_Overview_20141127.mxd
 Revised: 2014-11-27 By: pwnorell
 4885000

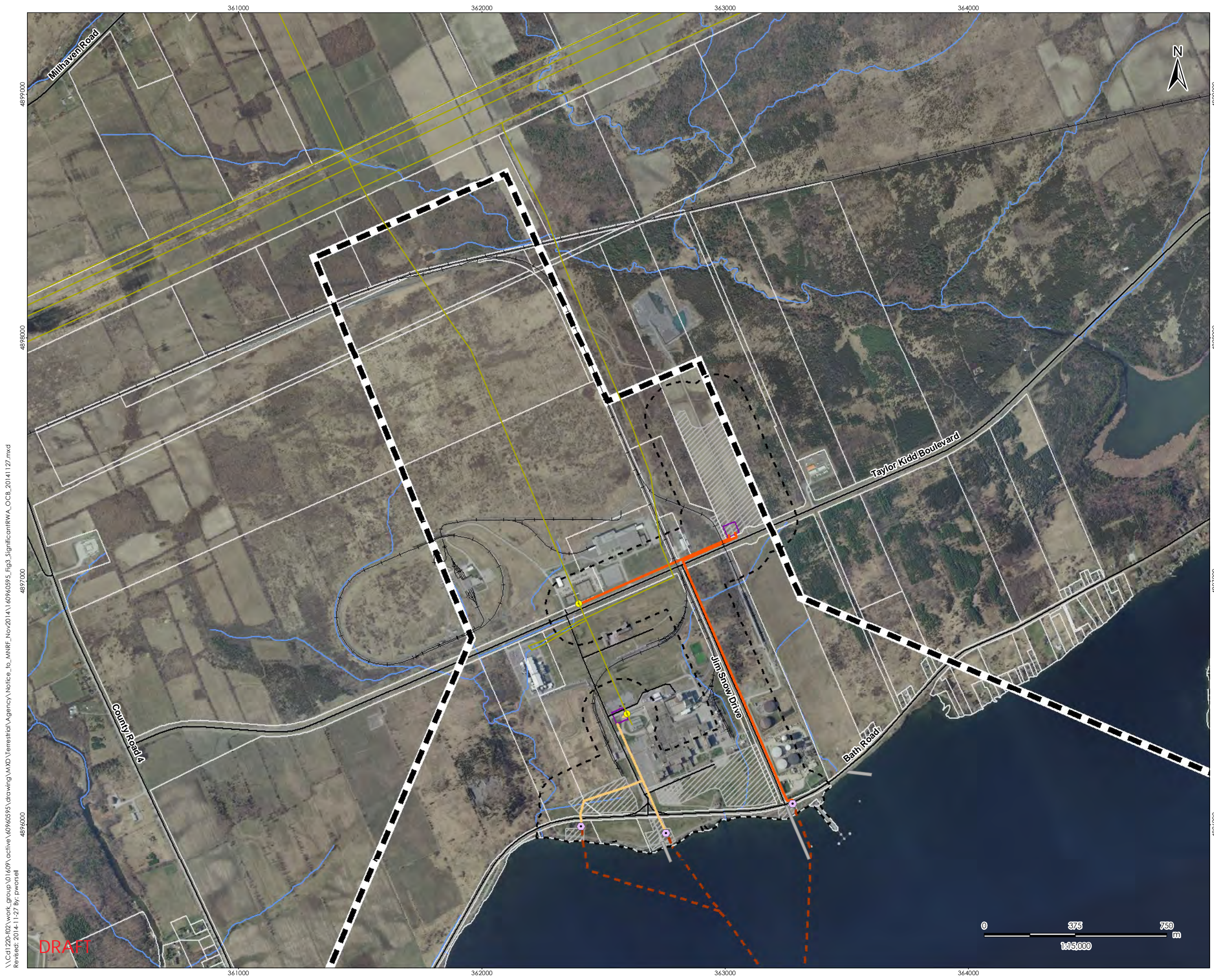

- Legend**
- Study Area
 - 120m Zone of Investigation
 - Project Components**
 - Turbine (No Changes Proposed)
 - Turbine (Removed)
 - Met Tower - Potential Location (No Changes Proposed)
 - Met Tower - Potential Location (Removed)
 - Access Road (No Changes Proposed)
 - Access Road (Removed)
 - Collector Line (Removed)
 - Collector Line (New) – within previously approved access road
 - Collector Line (Additional Project Design Change Modification)
 - Collector Line (No Proposed Changes)
 - Submarine Cable Path
 - Laydown Area and Crane Pad (No Changes Proposed)
 - Laydown Area and Crane Pad (Removed)
 - Operation and Maintenance Building (Potential Location)
 - Turbine Blade Tip (No Changes Proposed)
 - Turbine Blade Tip (Removed)
 - Substation (Potential Location)
 - Potential Culvert Location
 - Point of Common Coupling
 - Mainland Cable Vault (Potential Location)
 - Island Cable Vault
 - Aboveground Storage Tanks (Potential Location)
 - Constructible Area (No Proposed Changes)
 - Constructible Area (Removed)
 - Mainland Dock (Potential Location)
 - Island Dock
 - Batch Plant (Potential Location)
 - Site Office (Potential Location)
 - Storage Shed
 - Transmission Lines**
 - Mainland Option 1
 - Mainland Option 2
 - Island Transmission Line
 - Land Use**
 - Central Staging Area
 - Switching Station (Potential Location)
 - Existing Features**
 - Road
 - Unopened Road Allowance
 - Railway
 - Hydro Line
 - Watercourse
 - Property Line
 - Open Country Breeding Bird Area (OCB)
(OCB habitats are transparent with hatching)
 - Raptor Wintering Area (RWA)

Notes

1. Coordinate System: NAD 1983 UTM Zone 18N
2. Base features produced under license with the Ontario Ministry of Natural Resources © Queen's Printer for Ontario, 2014.
3. Orthoimagery © First Base Solutions, 2014. Imagery taken in 2008.

November 2014
160960595

Client/Project
Windlectric Inc.
Amherst Island Wind Energy Project

Figure No.
3.1 DRAFT

Title
Significant Open Country Breeding
Bird & Raptor Wintering Areas



\\C:\1220-102\work_group\01609\active\60960595\drawing\MXD\Terrestrial\Agency\Notice_to_MNRE_Nov2014\160960595_Fig3_SignificantRWA_OCB_20141127.mxd
 Revised: 2014-11-27 By: p.worsell

DRAFT

361000 362000 363000 364000 365000

4894000
4893000
4892000
4891000
4890000



Legend

- Study Area
- 120m Zone of Investigation
- Project Components
 - Turbine (No Changes Proposed)
 - Turbine (Removed)
 - Met Tower - Potential Location (No Changes Proposed)
 - Met Tower - Potential Location (Removed)
 - Access Road (No Changes Proposed)
 - Access Road (Removed)
 - Collector Line (Removed)
 - Collector Line (New) - within previously approved access road
 - Collector Line (Additional Project Design Change Modification)
 - Collector Line (No Proposed Changes)
 - Submarine Cable Path
 - Laydown Area and Crane Pad (No Changes Proposed)
 - Laydown Area and Crane Pad (Removed)
 - Operation and Maintenance Building (Potential Location)
 - Turbine Blade Tip (No Changes Proposed)
 - Turbine Blade Tip (Removed)
 - Substation (Potential Location)
 - Potential Culvert Location
 - Point of Common Coupling
 - Mainland Cable Vault (Potential Location)
 - Island Cable Vault
 - Aboveground Storage Tanks (Potential Location)
 - Constructible Area (No Proposed Changes)
 - Constructible Area (Removed)
 - Mainland Dock (Potential Location)
 - Island Dock
 - Batch Plant (Potential Location)
 - Site Office (Potential Location)
 - Storage Shed
- Transmission Lines
 - Mainland Option 1
 - Mainland Option 2
 - Island Transmission Line
- Land Use
 - Central Staging Area
 - Switching Station (Potential Location)
- Existing Features
 - Road
 - Unopened Road Allowance
 - Railway
 - Hydro Line
 - Watercourse
 - Property Line
 - Open Country Breeding Bird Area (OCB) (OCB habitats are transparent with hatching)
 - Raptor Wintering Area (RWA)

Notes

- Coordinate System: NAD 1983 UTM Zone 18N
- Base features produced under license with the Ontario Ministry of Natural Resources © Queen's Printer for Ontario, 2014.
- Orthoimagery © First Base Solutions, 2014. Imagery taken in 2008.

November 2014
160960595

Client/Project
Windlectric Inc.
Amherst Island Wind Energy Project

Figure No.
3.2 **DRAFT**

Title
Significant Open Country Breeding Bird & Raptor Wintering Areas



DRAFT
OCB-3

361000 362000 363000 364000 365000



\\C:\1220-102\work_group\01609\active\60960595\drawing\MXD\Terrestrial\Agency\Notice_to_MNRE_Nov2014\160960595_Fig3_SignificantRWA_OCB_20141127.mxd
Revised: 2014-11-27 By: p.worsell

Legend

- Study Area
- 120m Zone of Investigation
- Project Components
 - Turbine (No Changes Proposed)
 - Turbine (Removed)
 - Met Tower - Potential Location (No Changes Proposed)
 - Met Tower - Potential Location (Removed)
 - Access Road (No Changes Proposed)
 - Access Road (Removed)
 - Collector Line (Removed)
 - Collector Line (New) - within previously approved access road
 - Collector Line (Additional Project Design Change Modification)
 - Collector Line (No Proposed Changes)
 - Submarine Cable Path
 - Laydown Area and Crane Pad (No Changes Proposed)
 - Laydown Area and Crane Pad (Removed)
 - Operation and Maintenance Building (Potential Location)
 - Turbine Blade Tip (No Changes Proposed)
 - Turbine Blade Tip (Removed)
 - Substation (Potential Location)
 - Potential Culvert Location
 - Point of Common Coupling
 - Mainland Cable Vault (Potential Location)
 - Island Cable Vault
 - Aboveground Storage Tanks (Potential Location)
 - Constructible Area (No Proposed Changes)
 - Constructible Area (Removed)
 - Mainland Dock (Potential Location)
 - Island Dock
 - Batch Plant (Potential Location)
 - Site Office (Potential Location)
 - Storage Shed
- Transmission Lines
 - Mainland Option 1
 - Mainland Option 2
 - Island Transmission Line
- Land Use
 - Central Staging Area
 - Switching Station (Potential Location)
- Existing Features
 - Road
 - Unopened Road Allowance
 - Railway
 - Hydro Line
 - Watercourse
 - Property Line
 - Open Country Breeding Bird Area (OCB) (OCB habitats are transparent with hatching)
 - Raptor Wintering Area (RWA)

Notes

- Coordinate System: NAD 1983 UTM Zone 18N
- Base features produced under license with the Ontario Ministry of Natural Resources © Queen's Printer for Ontario, 2014.
- Orthoimagery © First Base Solutions, 2014. Imagery taken in 2008.

November 2014
160960595

Client/Project
Windelectric Inc.
Amherst Island Wind Energy Project

Figure No.
3.3 **DRAFT**

Title
Significant Open Country Breeding Bird & Raptor Wintering Areas



\\C:\1220-102\work_group\01609\active\60960595\drawing\MXD\Terrestrial\Agency\Notice_to_MNRE_Nov2014\160960595_Fig3_SignificantRWA_OCB_20141127.mxd
 Revised: 2014-11-27 By: p.worsell

DRAFT

OCB-6

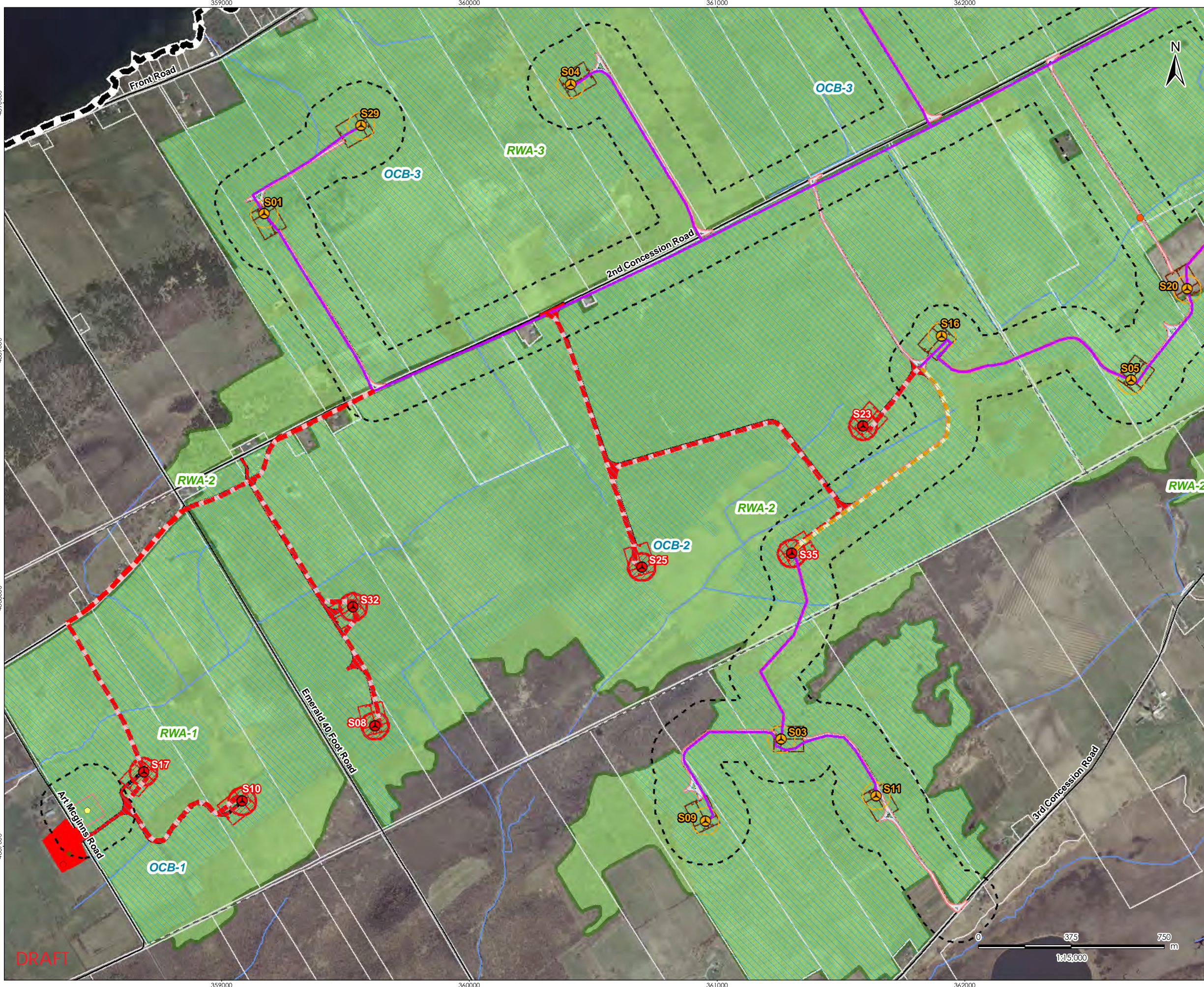

- Legend**
- Study Area
 - 120m Zone of Investigation
 - Project Components**
 - Turbine (No Changes Proposed)
 - Turbine (Removed)
 - Met Tower - Potential Location (No Changes Proposed)
 - Met Tower - Potential Location (Removed)
 - Access Road (No Changes Proposed)
 - Access Road (Removed)
 - Collector Line (Removed)
 - Collector Line (New) - within previously approved access road
 - Collector Line (Additional Project Design Change Modification)
 - Collector Line (No Proposed Changes)
 - Submarine Cable Path
 - Laydown Area and Crane Pad (No Changes Proposed)
 - Laydown Area and Crane Pad (Removed)
 - Operation and Maintenance Building (Potential Location)
 - Turbine Blade Tip (No Changes Proposed)
 - Turbine Blade Tip (Removed)
 - Substation (Potential Location)
 - Potential Culvert Location
 - Point of Common Coupling
 - Mainland Cable Vault (Potential Location)
 - Island Cable Vault
 - Aboveground Storage Tanks (Potential Location)
 - Constructible Area (No Proposed Changes)
 - Constructible Area (Removed)
 - Mainland Dock (Potential Location)
 - Island Dock
 - Batch Plant (Potential Location)
 - Site Office (Potential Location)
 - Storage Shed
 - Transmission Lines**
 - Mainland Option 1
 - Mainland Option 2
 - Island Transmission Line
 - Land Use**
 - Central Staging Area
 - Switching Station (Potential Location)
 - Existing Features**
 - Road
 - Unopened Road Allowance
 - Railway
 - Hydro Line
 - Watercourse
 - Property Line
 - Open Country Breeding Bird Area (OCB) (OCB habitats are transparent with hatching)
 - Raptor Wintering Area (RWA)

Notes

- Coordinate System: NAD 1983 UTM Zone 18N
- Base features produced under license with the Ontario Ministry of Natural Resources © Queen's Printer for Ontario, 2014.
- Orthoimagery © First Base Solutions, 2014. Imagery taken in 2008.

November 2014
160960595

Client/Project
Windlectric Inc.
Amherst Island Wind Energy Project

Figure No.
3.4 **DRAFT**

Title
Significant Open Country Breeding Bird & Raptor Wintering Areas

\\C:\1220-102\work_group\01609\active\60960595\drawing\MXD\Terrestrial\Agency\Notice_to_MNRE_Nov2014\160960595_Fig3_SignificantRWA_OCB_20141127.mxd
 Revised: 2014-11-27 By: p.worsell

DRAFT



- Legend**
- Study Area
 - 120m Zone of Investigation
 - Project Components**
 - Turbine (No Changes Proposed)
 - Turbine (Removed)
 - Met Tower - Potential Location (No Changes Proposed)
 - Met Tower - Potential Location (Removed)
 - Access Road (No Changes Proposed)
 - Access Road (Removed)
 - Collector Line (Removed)
 - Collector Line (New) - within previously approved access road
 - Collector Line (Additional Project Design Change Modification)
 - Collector Line (No Proposed Changes)
 - Submarine Cable Path
 - Laydown Area and Crane Pad (No Changes Proposed)
 - Laydown Area and Crane Pad (Removed)
 - Operation and Maintenance Building (Potential Location)
 - Turbine Blade Tip (No Changes Proposed)
 - Turbine Blade Tip (Removed)
 - Substation (Potential Location)
 - Potential Culvert Location
 - Point of Common Coupling
 - Mainland Cable Vault (Potential Location)
 - Island Cable Vault
 - Aboveground Storage Tanks (Potential Location)
 - Constructible Area (No Proposed Changes)
 - Constructible Area (Removed)
 - Mainland Dock (Potential Location)
 - Island Dock
 - Batch Plant (Potential Location)
 - Site Office (Potential Location)
 - Storage Shed
 - Transmission Lines**
 - Mainland Option 1
 - Mainland Option 2
 - Island Transmission Line
 - Land Use**
 - Central Staging Area
 - Switching Station (Potential Location)
 - Existing Features**
 - Road
 - Unopened Road Allowance
 - Railway
 - Hydro Line
 - Watercourse
 - Property Line
 - Open Country Breeding Bird Area (OCB) (OCB habitats are transparent with hatching)
 - Raptor Wintering Area (RWA)

Notes

1. Coordinate System: NAD 1983 UTM Zone 18N
2. Base features produced under license with the Ontario Ministry of Natural Resources © Queen's Printer for Ontario, 2014.
3. Orthoimagery © First Base Solutions, 2014. Imagery taken in 2008.

November 2014
160960595

Client/Project
Windlectric Inc.
Amherst Island Wind Energy Project

Figure No.
3.5 **DRAFT**

Title
Significant Open Country Breeding Bird & Raptor Wintering Areas



\\C:\1220-102\work_group\01609\active\60960595\drawing\MXD\Terrestrial\Agency\Notice_to_MNRE_Nov2014\160960595_Fig3_SignificantRWA_OCB_20141127.mxd
 Revised: 2014-11-27 By: pworthell
 4887000

DRAFT



Stantec Consulting Ltd.
70 Southgate Drive, Suite 1
Guelph ON N1G 4P5
Tel: (519) 836-6050
Fax: (519) 836-2493

January 7, 2015
File: 160960595

Attention: Clairissa Myschowoda

Ontario Ministry of Natural Resources and Forestry
Peterborough District
1st Floor, South Tower
300 Water St
Peterborough ON K9J 8M5

Dear Ms. Mychowoda,

Reference: Amherst Island Wind Energy Project Modifications - FINAL

This letter is submitted as an addendum to the Amherst Island Wind Energy Project Renewable Energy Approval Application – Natural Heritage Assessment and Environmental Impact Study (NHA/EIS, Stantec 2012) that was submitted to the Ministry of Natural Resources and Forestry (MNRF) in December 2012 and received a confirmation letter on December 12, 2012. This letter report should be read in association with that document.

The purpose of this letter is to provide the MNRF with an understanding of a modification that has been made to the location of underground collector lines since the NHA/EIS was confirmed by the MNRF, and to provide an assessment of the proposed modification in order to identify any additional potential effects, mitigation measures, or monitoring requirements that were not included in the NHA/EIS. This modification includes, specifically:

- The location of an underground collector line along South Shore Road and up to S13 (see **Figure 1, Attachment 1**).
- Removal of the portions of the proposed underground collector line along Stella 40 Foot Road and Front Road.

Site investigations had previously been completed at the location along South Shore Road and up to S13. As a result, additional site visits were not required to determine the status and boundary of natural features. Natural features that occur in or within 120 m of the revised Project Location are already identified on the maps provided within the NHA/EIS.

In addition to the modifications described above, a set of technical updates to the Project are also being proposed. These updates include a change in turbine model and associated reduction in the number of turbines, as well as the removal of associated access roads and collector line. These updates have been discussed with the Ministry of the Environment and Climate Change (MOECC), who has verified that the updates are a Technical Change as pursuant to the classification system outlined in the Ministry of the Environment's Technical Guide to Renewable Energy Approvals (October, 2013).



Reference: Amherst Island Wind Energy Project Modifications

Given the nature of the technical updates, they do not require modifications to the NHA/EIS or a re-confirmation of the NHA/EIS. A notification detailing this change will be MNRF under a separate cover.

DESCRIPTION OF PROJECT MODIFICATION

The Project modification involves the addition of an underground collector line along South Shore Road within the road right-of-way and on private land from the access road for S14 to S13. The modification would include removing portions of the underground collector line along Stella 40 Foot Road and Front Road (**Figure 1, Attachment 1**).

This proposed modification would involve rerouting the collection system to avoid the Village of Stella. In doing so, this modification would remove a significant portion of the existing collection system from S30 entrance along Front Road, including removing approximately 4 km of road allowance trenching (including through Stella). The modification would also require a new collection corridor from S13 to South Shore Rd. and west to S14 entrance, which would consist of approximately 1 km in road allowance and 700 m in pasture field.

The modification will decrease the Project Location size by resulting in a net reduction of approximately 2 km of collection system trenching. It will require only minimal additional natural heritage assessment along the additional 1.7 km of new collector line. As mentioned above, this additional area had been previously assessed as part of the December 2012 NHA, and no additional site visits were required.

The construction and installation activities for this underground collector line will be completed in the same manner (using the same mitigation measures) as the collector lines which are described in the Construction Plan Report, submitted as part of the REA Application.

CHANGE TO IDENTIFICATION OF NATURAL FEATURES WITHIN 120 M OF THE NEW PROJECT LOCATION

Changes to Records Review

A full Records Review for the area within 120 m of the new underground collector line was conducted. No changes are required to the Records Review of the NHA/EIS as the previous Records Review included the areas within the new Project location. Records Review methodology from the December 2012 NHA/EIS is provided in **Attachment 2**.

Results of the Records Review are provided in **Figure 1B, Attachment 1**. The Records Review identified one type of natural heritage feature within 120m of the new Project Location; significant woodlands as mapped by the Cataraqui Region Conservation Authority (CRCA).

Changes to Site Investigation

The methodology for the Site Investigation has not changed from the December 2012 NHA/EIS; methodology from the NHA/EIS is provided in **Attachment 3**.



Reference: Amherst Island Wind Energy Project Modifications

All natural heritage features described in the December 2012 NHA/EIS remain within 120 m of Project Location. As such, the Project modification does not result in removal of any discussion of natural features from the NHA/EIS. In addition, the modification results in only one new feature being within 120 m of the Project Location. A woodland feature is located within 120 m of the new underground collector line running along South Shore Road. This feature was identified in the mapping in the December 2012 NHA/EIS but was not located within the Zone of Investigation at that time. It is shown on **Figure 3, Attachment 1** as new Woodland Feature 22. A site investigation of this feature was completed on July 28, 2011. It is comprised of fresh-moist ash lowland deciduous forest (Ecological Land Classification code FOD7-2).

Table 7B in the NHA/EIS is updated with woodland feature 22. Additions to **Table 7B** are summarized below in **Attachment 2**.

Other candidate significant natural heritage features that occur within 120 m of the new section of underground collector line, which are Woodland 21, Shrub/early successional breeding birds (SSB4), Shorebird migratory stopover area (SM1) and Open country breeding bird areas (OCB-6 and OCB-7), were previously identified in the December 2012 NHA/EIS. Therefore, no further site investigations are required for these candidate significant features as a result of the proposed modifications.

The summary of candidate features in **Table 3.9** in the NHA/EIS is updated to include Woodland 22 and the distance calculation to candidate wildlife habitat feature SSB4. Distance calculations to candidate wildlife habitat features RWA-6, OCB-6 and SM1 have not changed from the December 2012 NHA/EIS. The updates to **Table 3.9** are provided below in **Attachment 2**. **Figures 3 and 4, Attachment 1** show the location of candidate natural heritage features.

Changes to Evaluation of Significance

The methodology for the Evaluation of Significance has not changed from the December 2012 NHA/EIS; methodology from the NHA/EIS is provided in **Attachment 3**.

As mentioned above, as a result of the proposed modifications, only one new feature occurs within 120 m of the Project Location requiring an Evaluation of Significance; Woodland 22. The woodland is 15.03 ha in size and is separated from Woodland Feature 21 by a band of cultural meadow of approximately 100 m wide, forming a distinct new woodland feature. The new woodland feature 22 is considered significant, as it is over 4 ha in size and provides a linkage function. **Table 10B** in the NHA/EIS is updated to include the evaluation of woodland feature 22. Additions to **Table 10B** are summarized below in **Attachment 2**.

As mentioned above, other candidate significant natural heritage features that occur within 120 m of the new section of underground collector line were previously identified in the December 2012 NHA/EIS. These include Woodland 21, Shrub/early successional breeding birds (SSB4), Shorebird migratory stopover area (SM1) and Open country breeding bird areas (OCB-6 and OCB-7):



Reference: Amherst Island Wind Energy Project Modifications

- Woodland 21 is comprised of lowland deciduous forest, deciduous swamp and thicket habitat. It was identified in the December 2012 NHA and evaluated as significant.
- Shrub/early successional breeding birds (SSB4), is comprised of a complex of cultural thicket and woodland which is within 120 m of the new underground collector line running south from S13 and along South Shore Road. SSB4 was identified in the December 2012 NHA and evaluated as significant.
- Shorebird migratory stopover area (SM1) occurs along the Amherst Island shoreline and is within 120 m of the of the new underground collector line running along South Shore Road. SM1 was identified in the December 2012 NHA and evaluated as significant.
- Open country breeding bird areas (OCB-6 and OCB-7) occur within 120 m of the new underground collector line. The new underground collector line that runs south of S13 overlaps with OCB-7. The new underground collector line running along South Shore Road is adjacent to OCB-6. Both OCB-6 and OCB-7 were identified in the December 2012 NHA and evaluated as significant.
- The new underground collector line that runs south of S13 overlaps with raptor wintering area RWA-6. The new underground collector line running along South Shore Road is also adjacent to RWA-6. RWA-6 was identified in the December 2012 NHA and evaluated as significant.

The evaluation of significance of these features in the December 2012 NHA does not change as a result of the Project modifications.

Given the above, the summary of significant features in **Table 4.8** in the NHA/EIS is updated to include Significant Woodland 22 and the distance calculation to significant wildlife habitat feature SSB4. No changes are required to distance calculations to significant wildlife habitat features RWA-6, OCB-6 and SM1. The updates to **Table 4.8** are provided below in **Attachment 2**. **Figures 5 and 6, Attachment 1** show the location of significant natural heritage features.

Change to Assessment of Impacts and Mitigation Measures

Minor changes to the EIS are required to address the new woodland feature 22, changes in Project distance to SSB-4 and temporary removal of habitat in RWA-6 and OCB-7.

Section 5.3.1 is herein updated to indicate 16 significant woodlands occur within 120 m of the Project Location, which includes the new woodland feature 22. There will be no direct encroachment or removal of vegetation in the woodland feature. The discussion of potential impacts to woodland from construction remains the same. The discussion of potential impacts to woodlands during operation in **Section 5.5.2** also remains unchanged. **Table 14B** is herein revised to include woodland feature 22 in the list of significant woodlands. No changes to impacts, mitigation, monitoring or contingency of impacts to woodlands in **Table 14B** are required.



Reference: Amherst Island Wind Energy Project Modifications

Because underground collector line was already present within significant wildlife habitat features RWA-6 and OCB-6, the discussion in **Sections 5.3.3** and **5.5.3** on potential impacts to significant wildlife habitat remains the same, with the exception of **Section 5.3.3.9** which is herein updated to indicate the closest Project components is the underground collector line that is 1 m away from the SSB4 in a public right of way. This will not require any vegetation removal. No additional potential impacts, beyond those discussed in **Sections 5.3.3** and **5.5.3** are anticipated to feature SSB4.

Table 13B is herein updated to include the portion of underground collector line in RWA-6 and OCB-7, between S13 and South Shore Road, in the amount of habitat that will be removed for short-term duration. Distances between Project components and these features have not changed; however, the total amount of raptor wintering area, open country breeding bird and short-eared owl habitat that will be temporarily removed is revised to increase by 0.56 ha.

Within 120 m of the new underground collector line, no wintering raptors were observed during the 2011/2012 winter raptor surveys. Two raptors were observed foraging in RWA-6 feature – Snowy Owl and Rough-legged Hawk. No Short-eared Owls were observed in RWA-6. As such, the results indicate the area of the new Project Location may support foraging habitat, but not roost habitat function.

Table A summarizes the potential impacts and recommended mitigation measures from the December 2012 NHA/EIS, for significant features within 120m of the new underground collector line. General construction mitigation from the NHA/EIS, which will be implemented during construction of the new underground collector line, is provided in **Attachment 3**.

Table A. Summary of Significant Features Located within 120 m of New Underground Collector Line

Feature	Original Distance to Project Components	Updated Distance to Project Components	Potential Impacts to Feature	Recommended Mitigation Measures
Woodland 21 and 22	WT-44 UL-3 AR-39 TC-40	UL – 82	Indirect impacts to significant woodlands resulting from construction activities, such as dust generation, sedimentation and erosion are expected to be short term, temporary in duration and mitigable through the use of standard site control measures. No impacts are anticipated during the operation of the new underground collector line.	Standard site control measures as described in Section 5.4 of NHA/EIS, which includes all measures for vegetation removal (including timing for impacts to wildlife), sediment and erosion control, and other general mitigation measures. Section 5.4 of NHA/EIS can be found in Attachment 3 . In addition, the following mitigation measures apply that were committed to in the original NHA/EIS (Table 14B):



Reference: Amherst Island Wind Energy Project Modifications

Table A. Summary of Significant Features Located within 120 m of New Underground Collector Line

Feature	Original Distance to Project Components	Updated Distance to Project Components	Potential Impacts to Feature	Recommended Mitigation Measures
				<ul style="list-style-type: none"> • The boundaries of the limit of construction within grassland habitat will be delineated and flagged / staked in the field by a qualified ecologist prior to construction to assist with the demarcation of the construction area, to ensure construction activities do not encroach beyond the limited construction area. • Workers will be advised not to trespass beyond the boundary of the marked area. • Erect silt fencing to prevent sedimentation within critical root zones • Implement a sedimentation and erosion control plan. • Any issues should be resolved in a timely fashion. • Implement dust suppression (i.e. watering) on access roads as required. • All maintenance activities, vehicle refueling or washing and chemical storage will be located more than 30m from significant woodlands. • Implement infiltration (i.e. minimize paved surfaces and design roads to promote infiltration) techniques to the maximum extent possible to avoid changes in soil moisture and compaction.
SSB4	WT – 65 UL – 70 AR – 66 TC - 65	WT – 65 UL – 1 AR – 66 TC - 65	There will be no direct loss of habitat or function to the significant shrub/successional breeding bird features. Indirect impacts during construction could include	Standard site control measures as described in Section 5.4 of NHA/EIS, which includes all measures for vegetation removal (including timing for impacts to wildlife), sediment and erosion



Reference: Amherst Island Wind Energy Project Modifications

Table A. Summary of Significant Features Located within 120 m of New Underground Collector Line

Feature	Original Distance to Project Components	Updated Distance to Project Components	Potential Impacts to Feature	Recommended Mitigation Measures
			<p>disturbance or disruption to breeding birds. Disturbance from construction activities, such as increased traffic, noise, or dust, may result in avoidance of habitats by birds. These effects may be greatest if disturbance occurs during critical life stages such as courtship or nesting.</p> <p>No impacts are anticipated during the operation of the new underground collector line.</p>	<p>control, and other general mitigation measures. Section 5.4 of NHA/EIS can be found in Attachment 3.</p> <p>In addition, the following mitigation measures apply that were committed to in the original NHA/EIS (Table 14B):</p> <ul style="list-style-type: none"> • Erect silt fencing to prevent sedimentation • Implement a sedimentation and erosion control plan • Any issues should be resolved in a timely fashion • Implement dust suppression (i.e. watering) on access roads as required • All maintenance activities, vehicle refueling or washing and chemical storage will be located more than 30m from significant features
SM1	UL – overlapping AR – overlapping	UL – overlapping AR – overlapping	<p>The new underground collector line is located outside of this feature; therefore, no loss of habitat will occur for the construction of this Project component.</p> <p>Potential indirect impacts to migratory shorebirds from the Project during construction include disturbance due to increased traffic, noise, or dust. The most adverse impacts associated with construction noise typically occur if critical life cycle activities are disrupted (i.e. nesting, mating) (NWCC 2002). Because migrating shorebirds in general are able</p>	<p>Standard site control measures as described in Section 5.4 of NHA/EIS, which includes all measures for vegetation removal (including timing for impacts to wildlife), sediment and erosion control, and other general mitigation measures. Section 5.4 of NHA/EIS can be found in Attachment 3.</p> <p>In addition, the following mitigation measures apply that were committed to in the original NHA/EIS (Table 14B):</p> <ul style="list-style-type: none"> • Erect silt fencing to prevent sedimentation • Implement a sedimentation and erosion control plan • Any issues should be resolved in



Reference: Amherst Island Wind Energy Project Modifications

Table A. Summary of Significant Features Located within 120 m of New Underground Collector Line

Feature	Original Distance to Project Components	Updated Distance to Project Components	Potential Impacts to Feature	Recommended Mitigation Measures
			<p>to use a much wider range of habitat types during migration compared to the breeding season, it is expected that the effects of disturbance would be less significant during migration than during the breeding season.</p> <p>No impacts are anticipated during the operation of the new underground collector line.</p>	<p><i>a timely fashion</i></p> <ul style="list-style-type: none"> • <i>Implement dust suppression (i.e. watering) on access roads as required</i> • <i>All maintenance activities, vehicle refueling or washing and chemical storage will be located more than 30m from significant features</i>
RWA-6	WT – overlapping AR – overlapping UL – overlapping TC – overlapping BU – overlapping	WT – overlapping AR – overlapping UL – overlapping TC – overlapping BU – overlapping	<p>As the majority of the island is comprised of grassland habitat, avoidance of this habitat type was not possible; most Project components are sited in significant raptor wintering areas.</p> <p>Ground roosting sites for Short-eared Owls do not appear to be a limiting factor on Amherst Island. This small loss of habitat temporarily during construction is anticipated to have a negligible impact on the availability of roost sites within the Study Area. In most cases, Short-eared Owls would be expected to continue using sites adjacent to Project components, as documented on other wind projects (i.e. Wolfe Island).</p> <p>Because wintering raptors can use nearby habitats, this temporary disturbance is not anticipated to impact raptors using this feature.</p> <p>Potential impacts to this feature include disturbance</p>	<p>Standard site control measures as described in Section 5.4 of NHA/EIS, which includes all measures for vegetation removal (including timing for impacts to wildlife), sediment and erosion control, and other general mitigation measures, will be applied to the underground collector line located within this significant wildlife habitat. Any disturbed areas will be re-seeded immediately after construction. Section 5.4 of NHA/EIS can be found in Attachment 3.</p> <p>In addition, the following mitigation measures apply that were committed to in the original NHA/EIS (Table 14B):</p> <ul style="list-style-type: none"> • <i>The boundaries of the limit of construction within grassland habitat will be delineated and flagged / staked in the field by a qualified ecologist prior to construction to assist with the demarcation of the construction area, to ensure construction activities do not encroach beyond the limited</i>



Reference: Amherst Island Wind Energy Project Modifications

Table A. Summary of Significant Features Located within 120 m of New Underground Collector Line

Feature	Original Distance to Project Components	Updated Distance to Project Components	Potential Impacts to Feature	Recommended Mitigation Measures
			<p>due to increased traffic and noise, dust generation, sedimentation and erosion during construction.</p> <p>No permanent habitat loss will occur from the construction of the new underground collector line.</p> <p>No impacts are anticipated during the operation of the new underground collector line.</p>	<p>construction area.</p> <ul style="list-style-type: none"> Implement dust suppression (i.e. watering) on access roads as required.
OCB-7	WT – overlapping AR – overlapping UL – overlapping TC – overlapping BU – overlapping	WT – overlapping AR – overlapping UL – overlapping TC – overlapping BU – overlapping	<p>As the majority of the island is comprised of grassland habitat, avoidance of this habitat type was not possible; most project components are sited in the significant open country breeding bird habitat and Short-eared Owl breeding habitat.</p> <p>Within 120m of the new collector line, habitat consists of actively managed hay fields.</p> <p>The implementation of mitigation measures such as avoiding activities that could disturb or destroy nests during key periods or protecting active nests with buffer zones reduces potential impacts to nests.</p> <p>Construction activities have the potential to result in disturbance or disruption to breeding birds. Disturbance from construction activity, such as increased traffic, noise, or dust, may result in</p>	<p>Standard site control measures as described in Section 5.4 of NHA/EIS, which includes all measures for vegetation removal (including timing for impacts to wildlife), sediment and erosion control, and other general mitigation measures, will be applied to the underground collector line located within this significant wildlife habitat. Any disturbed areas will be re-seeded immediately after construction. Section 5.4 of NHA/EIS can be found in Attachment 3.</p> <p>In addition, the following mitigation measures apply that were committed to in the original NHA/EIS (Table 14B):</p> <ul style="list-style-type: none"> Construction activities have the potential to result in disturbance or disruption to breeding birds. Disturbance from construction activity, such as increased traffic, noise, or dust, may result in avoidance of habitats by birds. These effects may be greatest if disturbance occurs during



Reference: Amherst Island Wind Energy Project Modifications

Table A. Summary of Significant Features Located within 120 m of New Underground Collector Line

Feature	Original Distance to Project Components	Updated Distance to Project Components	Potential Impacts to Feature	Recommended Mitigation Measures
			<p>avoidance of habitats by birds. These effects may be greatest if disturbance occurs during critical life stages such as courtship or nesting Wiggins et al. (2006) reports that nests from previous years may occasionally be reused. However, Short-eared Owl research on Amherst Island in 2009 and 2010 (Keyes 2011) found low site fidelity between years. As such, breeding territories from previous years may not be a good indicator of territory location during construction.</p> <p>No impacts are anticipated during the operation of the new underground collector line.</p>	<p><i>critical life stages such as courtship or nesting.</i></p> <ul style="list-style-type: none"> • <i>Identification of potential Short-eared Owl breeding territories. Restricted construction activities in proximity to potential breeding territories.</i> • <i>The boundaries of the limit of construction within grassland habitat will be delineated and flagged / staked in the field by a qualified ecologist prior to construction to assist with the demarcation of the construction area, to ensure construction activities do not encroach beyond the limited construction area.</i> • <i>Implement dust suppression (i.e. watering) on access roads as required.</i>

Legend: WT: Wind Turbine; UL: Underground Transmission Line; AR: Access Road, OL: Overhead Transmission Line, TC: Temporary Construction Areas, BU: Building/Substation

OVERALL ASSESSMENT OF CHANGES TO NHA/EIS

The Project modification will result in minor changes to the NHA/EIS, including addition of significant woodland feature 22 and revised distance calculations to significant wildlife habitat feature SSB4. The changes result in revisions to the Site Investigation (**Section 4.2.2, Table 3.9 and 7B**), Evaluation of Significance (**Section 5.3.1, 5.3.3.9, Tables 4.8 and 10B**) and the EIS (**Tables 13B and 14B**) of the NHA/EIS as discussed above.



January 7, 2015
Clairissa Myschowoda
Page 11 of 11

Reference: Amherst Island Wind Energy Project Modifications

CLOSING

Stantec Consulting Ltd. prepared this letter report for Windlectric Inc. for the Amherst Island Wind Energy Project. Windlectric Inc. is committed to implementing the appropriate protection and mitigation measures as they apply to the construction and operation of the proposed Project.

Regards,

STANTEC CONSULTING LTD.

Katherine St. James

Katherine St. James, M.Sc
Terrestrial Ecologist
Phone: (519) 836-6050
Fax: (519) 836-2493
katherine.stjames@stantec.com

c. Alex Tsopelas, Algonquin Power Co.
Sean Fairfield, Algonquin Power Co.
Kerrie Skillen, Stantec Consulting Ltd.

Attachments:

Attachment 1: Updates to NHA Figures
Attachment 2: Updates to NHA Table
Attachment 3: Sections of NHA/EIS

ks w:\active\60960595\reports\03_modification reports\rep_modification_no_3_draft\mnr letters\project design change_nha amendment - final\ltr_60595_aiwip-nha-amendment-
updated_20150107_fin.docx

Attachment 1

Updates to NHA Figures

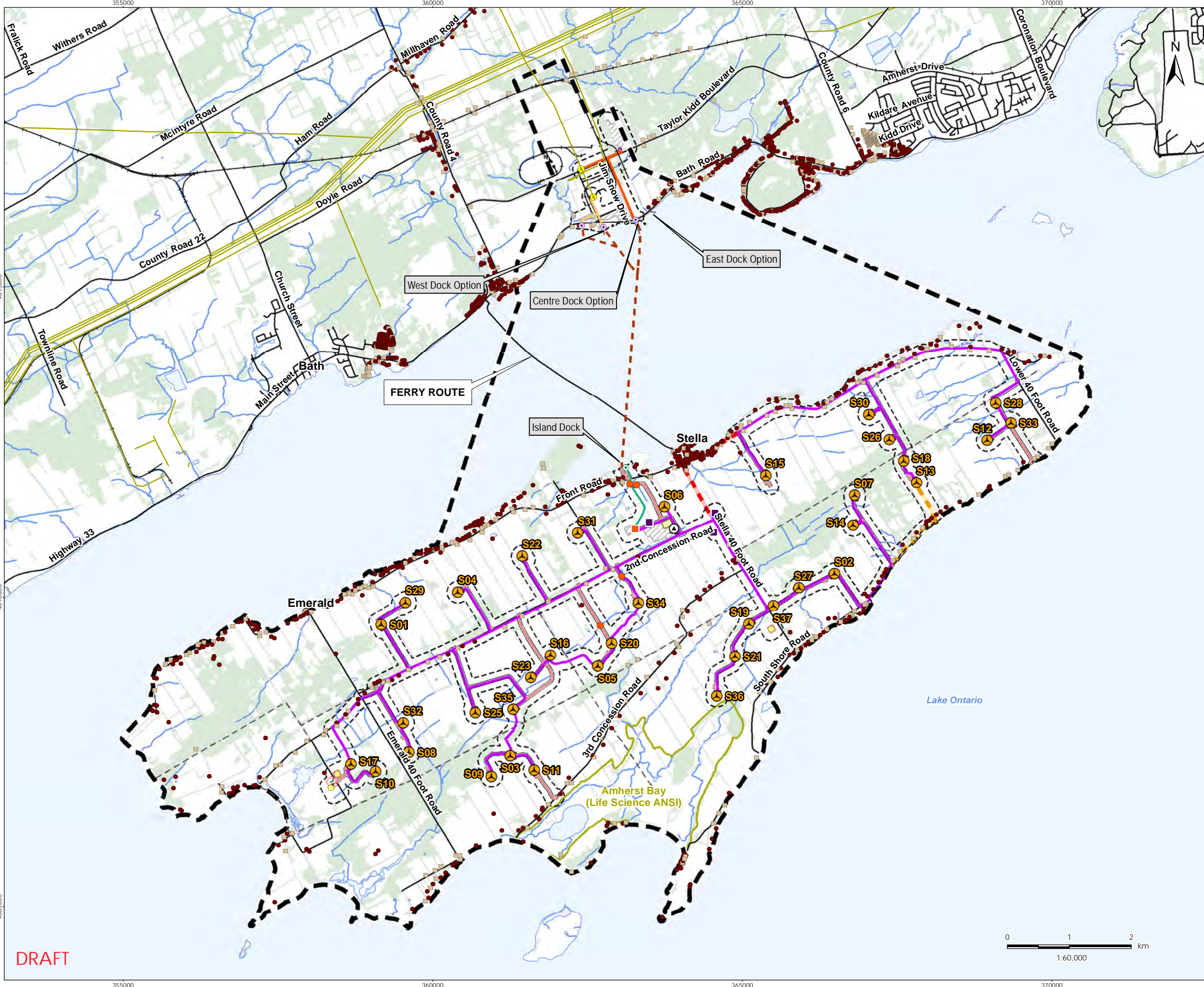

- Legend**
- Study Area
 - 120m Zone of Investigation
 - Project Components**
 - Turbine
 - Met Tower (Potential Location)
 - Substation (Potential Location)
 - Access Road
 - Collector Line
 - Collector Line (New)
 - Collector Line (Removed)
 - Submarine Cable Path
 - Laydown Area and Crane Pad
 - Operation and Maintenance Building (Potential Location)
 - Potential Culvert Location
 - Point of Common Coupling
 - Mainland Cable Vault (Potential Location)
 - Island Cable Vault
 - Aboveground Storage Tanks (Potential Location)
 - Constructible Area
 - Mainland Dock (Potential Location)
 - Island Dock
 - Batch Plant (Potential Location)
 - Site Office (Potential Location)
 - Storage Shed
 - Transmission Lines**
 - Mainland Option 1
 - Mainland Option 2
 - Island Transmission Line
 - Land Use**
 - Central Staging Area
 - Switching Station (Potential Location)
 - Noise Receptors**
 - Existing
 - Vacant
 - Existing Features**
 - Road
 - Unopened Road Allowance
 - Railway
 - Hydro Line
 - Watercourse
 - Waterbody
 - Wooded Area
 - ANSI Boundary
 - Property Line

Notes

- Coordinate System: NAD 1983 UTM Zone 18N
- Base features produced under license with the Ontario Ministry of Natural Resources © Queen's Printer for Ontario, 2014.

November 2014
160960595

Client/Project
Windlectric Inc.
Amherst Island Wind Energy Project

Figure No.
1A

DRAFT

Title
Project Location & Study Area

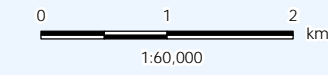

DRAFT

\\cd1220-102\01609\active\60960595\drawing\MXD\Terrestrial\NHA\Mod_Report\160960595_Fig1A_ProjectLocation_Overview_20141111.mxd
 Revised: 2014-11-12 By: p.worsell
 4885000

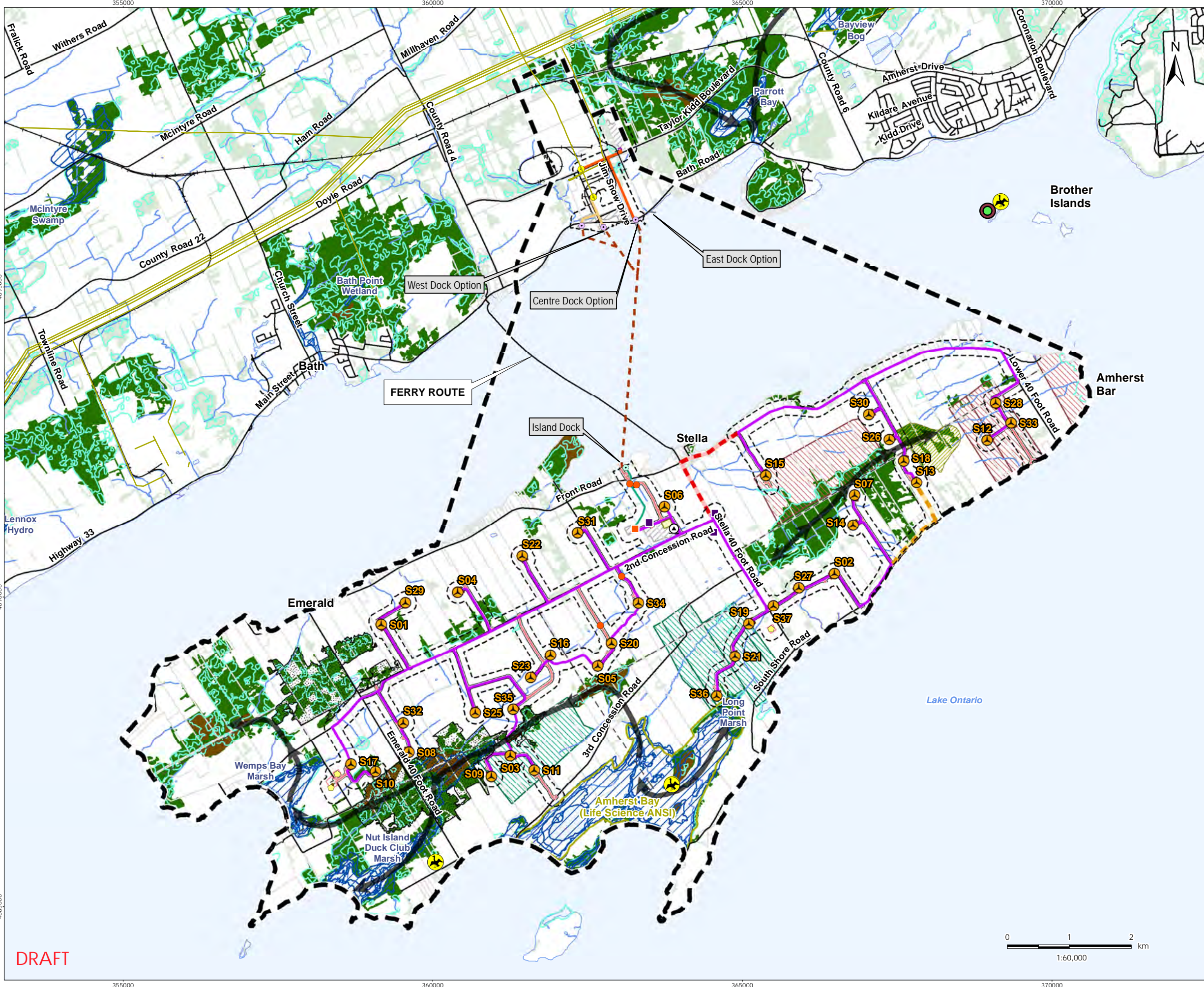

- Legend**
- Study Area
 - 120m Zone of Investigation
 - Project Components
 - Turbine
 - Met Tower (Potential Location)
 - Substation (Potential Location)
 - Access Road
 - Collector Line
 - Collector Line (New)
 - Collector Line (Removed)
 - Submarine Cable Path
 - Laydown Area and Crane Pad
 - Operation and Maintenance Building (Potential Location)
 - Potential Culvert Location
 - Point of Common Coupling
 - Mainland Cable Vault (Potential Location)
 - Island Cable Vault
 - Aboveground Storage Tanks (Potential Location)
 - Constructible Area
 - Mainland Dock (Potential Location)
 - Island Dock
 - Batch Plant and Maintenance (Potential Location)
 - Site Office (Potential Location)
 - Storage Shed
 - Transmission Lines
 - Mainland Option 1
 - Mainland Option 2
 - Island Transmission Line
 - Land Use
 - Central Staging Area
 - Switching Station (Potential Location)
 - Existing Features
 - Road
 - Unopened Road Allowance
 - Railway
 - Hydro Line
 - Watercourse
 - Waterbody
 - Provincially Significant Wetland
 - Unevaluated Wetland
 - Wooded Area
 - Significant Woodlot
 - ANSI Boundary
 - Owl Woods
 - Old Growth Woodlot
 - Property Line
 - Common Tern Nesting Site/Colony
 - Herring Gull Nesting Site/Colony
 - Wildlife Habitat Linkage
 - Colonial Waterbirds Site
 - Bald Eagle Nesting, Foraging, and Perching Habitat
 - Short-eared Owl Breeding Territory

Notes

- Coordinate System: NAD 1983 UTM Zone 18N
- Base features produced under license with the Ontario Ministry of Natural Resources © Queen's Printer for Ontario, 2014.

November 2014
160960595

Client/Project
Windlectric Inc.
Amherst Island Wind Energy Project

Figure No.
1B

DRAFT

Title
Natural Features - Records Review

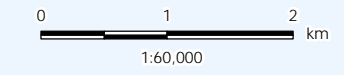

DRAFT

\\cd1220-102\01609\active\60960595\drawing\MXD\Terrestrial\NHA\Mod_Report\160960595_Fig1B_NaturalFeatures_RecReview_20141111.mxd
 Revised: 2014-11-12 By: p.worsell
 4885000

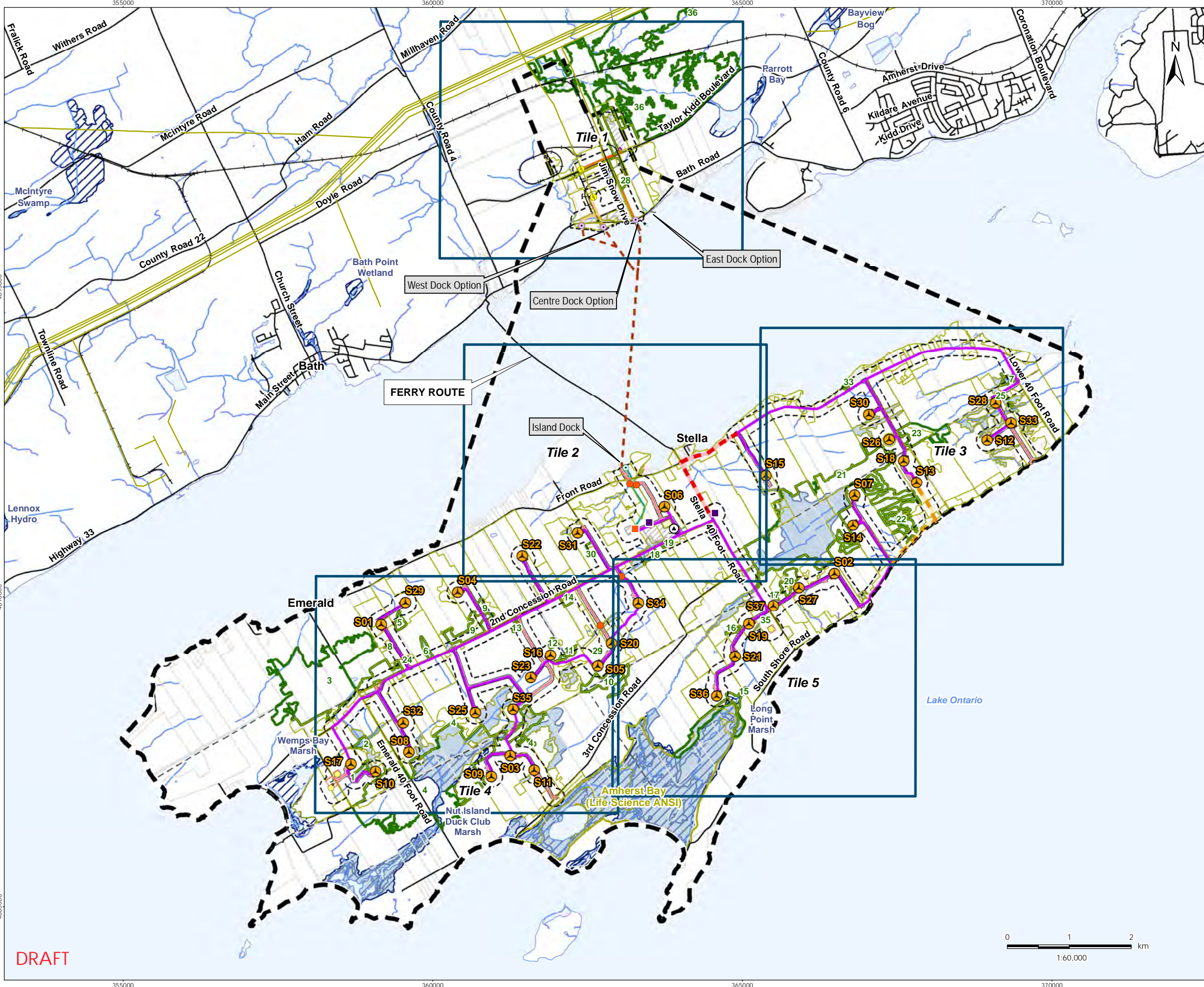

- Legend**
- Study Area
 - 120m Zone of Investigation
 - Project Components**
 - Turbine
 - Met Tower (Potential Location)
 - Substation (Potential Location)
 - Access Road
 - Collector Line
 - Collector Line (New)
 - Collector Line (Removed)
 - Submarine Cable Path
 - Laydown Area and Crane Pad
 - Operation and Maintenance Building (Potential Location)
 - Potential Culvert Location
 - Point of Common Coupling
 - Mainland Cable Vault (Potential Location)
 - Island Cable Vault
 - Aboveground Storage Tanks (Potential Location)
 - Constructible Area
 - Mainland Dock (Potential Location)
 - Island Dock
 - Batch Plant (Potential Location)
 - Site Office (Potential Location)
 - Storage Shed
 - Transmission Lines**
 - Mainland Option 1
 - Mainland Option 2
 - Island Transmission Line
 - Land Use**
 - Central Staging Area
 - Switching Station (Potential Location)
 - Existing Features**
 - Road
 - Unopened Road Allowance
 - Railway
 - Hydro Line
 - Watercourse
 - Waterbody
 - ANSI Boundary
 - Property Line
 - Provincially Significant Wetland (MNR)
 - Woodland Delineation (Stantec)
 - Wetland Delineation (Stantec)
 - ELC Boundary

Notes

- Coordinate System: NAD 1983 UTM Zone 18N
- Base features produced under license with the Ontario Ministry of Natural Resources © Queen's Printer for Ontario, 2014.

November 2014
160960595

Client/Project
Windlectric Inc.
Amherst Island Wind Energy Project

Figure No.
2.0 **DRAFT**

Title
ELC Vegetation Communities &
Woodland/Wetland Natural
Features - Overview

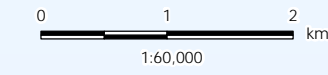

DRAFT

\\cd1220-102\01609\active\60960595\drawing\MXD\Terrestrial\NHA\Mod_Report\160960595_Fig2_ELC_Overview_20141111.mxd
 Revised: 2014-11-12 By: p.worsell
 4885000

- Legend**
- Study Area
 - 120m Zone of Investigation
 - Project Components**
 - Turbine
 - Met Tower (Potential Location)
 - Access Road
 - Collector Line
 - Collector Line (New)
 - Collector Line (Removed)
 - Submarine Cable Path
 - Laydown Area and Crane Pad
 - Operation and Maintenance Building (Potential Location)
 - Turbine Blade Tip
 - Substation (Potential Location)
 - Potential Culvert Location
 - Point of Common Coupling
 - Mainland Cable Vault (Potential Location)
 - Island Cable Vault
 - Aboveground Storage Tanks (Potential Location)
 - Constructible Area
 - Mainland Dock (Potential Location)
 - Island Dock
 - Batch Plant (Potential Location)
 - Site Office (Potential Location)
 - Storage Shed
 - Transmission Lines**
 - Mainland Option1
 - Mainland Option 2
 - Island Transmission Line
 - Land Use**
 - Central Staging Area
 - Switching Station (Potential Location)
 - Existing Features**
 - Road
 - Unopened Road Allowance
 - Railway
 - Hydro Line
 - Watercourse
 - Property Line
 - Provincially Significant Wetland (MNR)
 - Woodland Delineation (Stantec)
 - Wetland Delineation (Stantec)
 - ELC Boundary

- Notes**
- Coordinate System: NAD 1983 UTM Zone 18N
 - Base features produced under license with the Ontario Ministry of Natural Resources © Queen's Printer for Ontario, 2014.
 - Orthoimagery © First Base Solutions, 2014. Imagery taken in 2008.

November 2014
160960595

Client/Project
Windlectric Inc.
Amherst Island Wind Energy Project

Figure No.
2.1 **DRAFT**

Title
ELC Vegetation Communities &
Woodland/Wetland Natural
Features



\\cd1220-102\01609\active\60960595\drawing\MXD\Terrestrial\NHA\Mod_Report\160960595_Fig2_ELC_20141111.mxd
Revised: 2014-11-12 By: pworsell

DRAFT

- Legend**
- Study Area
 - 120m Zone of Investigation
 - Project Components**
 - Turbine
 - Met Tower (Potential Location)
 - Access Road
 - Collector Line
 - Collector Line (New)
 - Collector Line (Removed)
 - Submarine Cable Path
 - Laydown Area and Crane Pad
 - Operation and Maintenance Building (Potential Location)
 - Turbine Blade Tip
 - Substation (Potential Location)
 - Potential Culvert Location
 - Point of Common Coupling
 - Mainland Cable Vault (Potential Location)
 - Island Cable Vault
 - Aboveground Storage Tanks (Potential Location)
 - Constructible Area
 - Mainland Dock (Potential Location)
 - Island Dock
 - Batch Plant (Potential Location)
 - Site Office (Potential Location)
 - Storage Shed
 - Transmission Lines**
 - Mainland Option1
 - Mainland Option 2
 - Island Transmission Line
 - Land Use**
 - Central Staging Area
 - Switching Station (Potential Location)
 - Existing Features**
 - Road
 - Unopened Road Allowance
 - Railway
 - Hydro Line
 - Watercourse
 - Property Line
 - Provincially Significant Wetland (MNR)
 - Woodland Delineation (Stantec)
 - Wetland Delineation (Stantec)
 - ELC Boundary

- Notes**
- Coordinate System: NAD 1983 UTM Zone 18N
 - Base features produced under license with the Ontario Ministry of Natural Resources © Queen's Printer for Ontario, 2014.
 - Orthoimagery © First Base Solutions, 2014. Imagery taken in 2008.

November 2014
160960595

Client/Project
Windlectric Inc.
Amherst Island Wind Energy Project

Figure No.
2.2

DRAFT

Title
ELC Vegetation Communities &
Woodland/Wetland Natural
Features



\\cd1220-02\01609\active\60960595\drawing\MXD\Terrestrial\NHA\Mod_Report\160960595_Fig2_ELC_20141111.mxd
 Revised: 2014-11-12 By: p.worsell



- Legend**
- Study Area
 - 120m Zone of Investigation
 - Project Components
 - Turbine
 - Met Tower (Potential Location)
 - Access Road
 - Collector Line
 - Collector Line (New)
 - Collector Line (Removed)
 - Submarine Cable Path
 - Laydown Area and Crane Pad
 - Operation and Maintenance Building (Potential Location)
 - Turbine Blade Tip
 - Substation (Potential Location)
 - Potential Culvert Location
 - Point of Common Coupling
 - Mainland Cable Vault (Potential Location)
 - Island Cable Vault
 - Aboveground Storage Tanks (Potential Location)
 - Constructible Area
 - Mainland Dock (Potential Location)
 - Island Dock
 - Batch Plant (Potential Location)
 - Site Office (Potential Location)
 - Storage Shed
 - Transmission Lines
 - Mainland Option1
 - Mainland Option 2
 - Island Transmission Line
 - Land Use
 - Central Staging Area
 - Switching Station (Potential Location)
 - Existing Features
 - Road
 - Unopened Road Allowance
 - Railway
 - Hydro Line
 - Watercourse
 - Property Line
 - Provincially Significant Wetland (MNR)
 - Woodland Delineation (Stantec)
 - Wetland Delineation (Stantec)
 - ELC Boundary

- Notes**
- Coordinate System: NAD 1983 UTM Zone 18N
 - Base features produced under license with the Ontario Ministry of Natural Resources © Queen's Printer for Ontario, 2014.
 - Orthoimagery © First Base Solutions, 2014. Imagery taken in 2008.

November 2014
160960595

Client/Project
Windlectric Inc.
Amherst Island Wind Energy Project

Figure No.
2.3 **DRAFT**

Title
ELC Vegetation Communities &
Woodland/Wetland Natural
Features



\\cd1220-02\01609\active\60960595\drawing\MXD\Terrestrial\NHA\Mod_Report\160960595_Fig2_ELC_20141111.mxd
Revised: 2014-11-12 By: pworsell

DRAFT

- Legend**
- Study Area**
- 120m Zone of Investigation
- Project Components**
- Turbine
 - Met Tower (Potential Location)
 - Access Road
 - Collector Line
 - Collector Line (New)
 - Collector Line (Removed)
 - Submarine Cable Path
 - Laydown Area and Crane Pad
 - Operation and Maintenance Building (Potential Location)
 - Turbine Blade Tip
 - Substation (Potential Location)
 - Potential Culvert Location
 - Point of Common Coupling
 - Mainland Cable Vault (Potential Location)
 - Island Cable Vault
 - Aboveground Storage Tanks (Potential Location)
 - Constructible Area
 - Mainland Dock (Potential Location)
 - Island Dock
 - Batch Plant (Potential Location)
 - Site Office (Potential Location)
 - Storage Shed
- Transmission Lines**
- Mainland Option1
 - Mainland Option 2
 - Island Transmission Line
- Land Use**
- Central Staging Area
 - Switching Station (Potential Location)
- Existing Features**
- Road
 - Unopened Road Allowance
 - Railway
 - Hydro Line
 - Watercourse
 - Property Line
 - Provincially Significant Wetland (MNR)
 - Woodland Delineation (Stantec)
 - Wetland Delineation (Stantec)
 - ELC Boundary

Notes

- Coordinate System: NAD 1983 UTM Zone 18N
- Base features produced under license with the Ontario Ministry of Natural Resources © Queen's Printer for Ontario, 2014.
- Orthoimagery © First Base Solutions, 2014. Imagery taken in 2008.

November 2014
160960595

Client/Project
Windlectric Inc.
Amherst Island Wind Energy Project

Figure No.
2.4

DRAFT

Title
ELC Vegetation Communities &
Woodland/Wetland Natural
Features

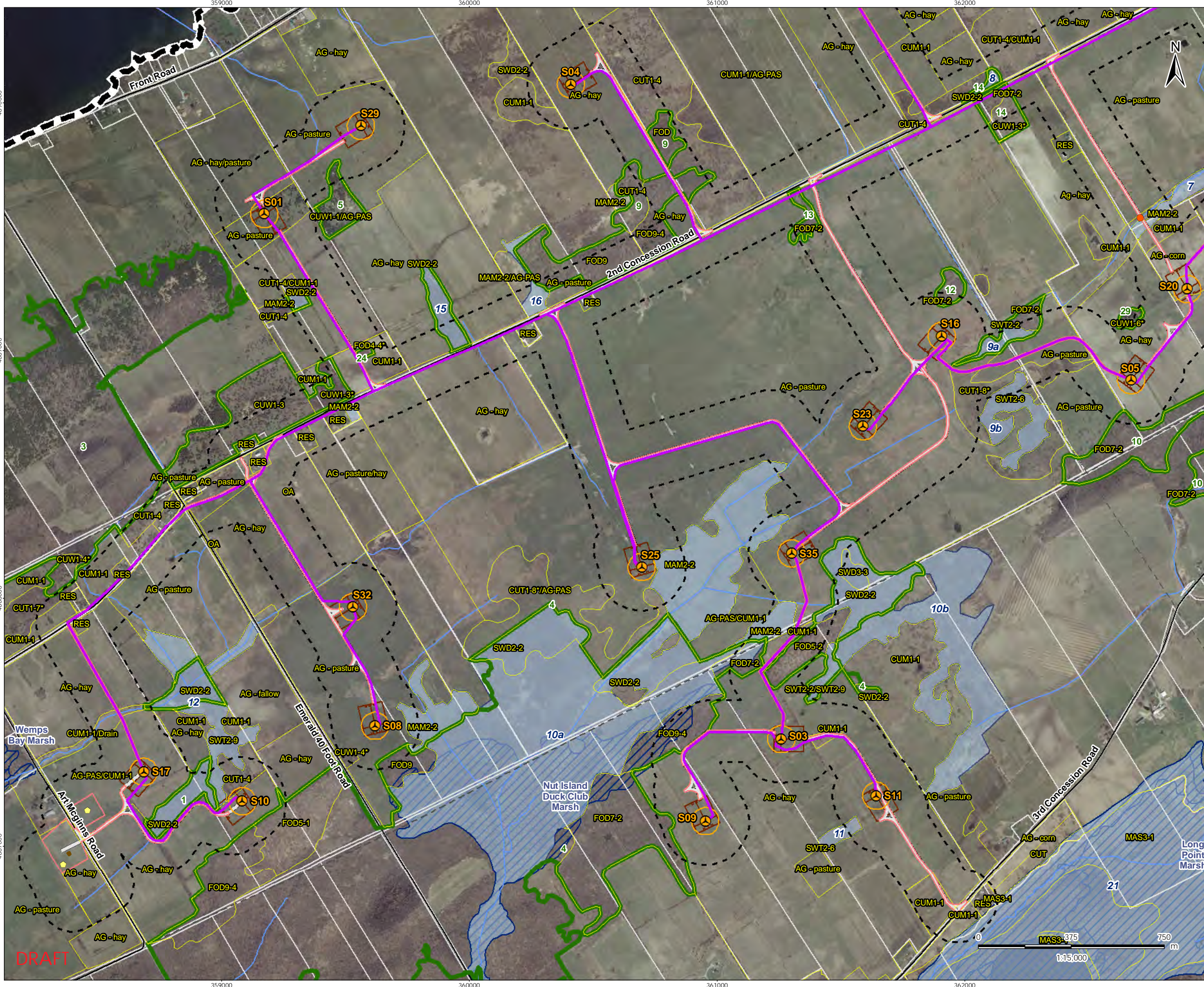

\\cd1220-02\01609\active\60960595\drawing\MXD\Terrestrial\NHA\Mod_Report\160960595_Fig2_ELC_20141111.mxd
Reviewed: 2014-11-12 By: pwnorsell
4887000

DRAFT

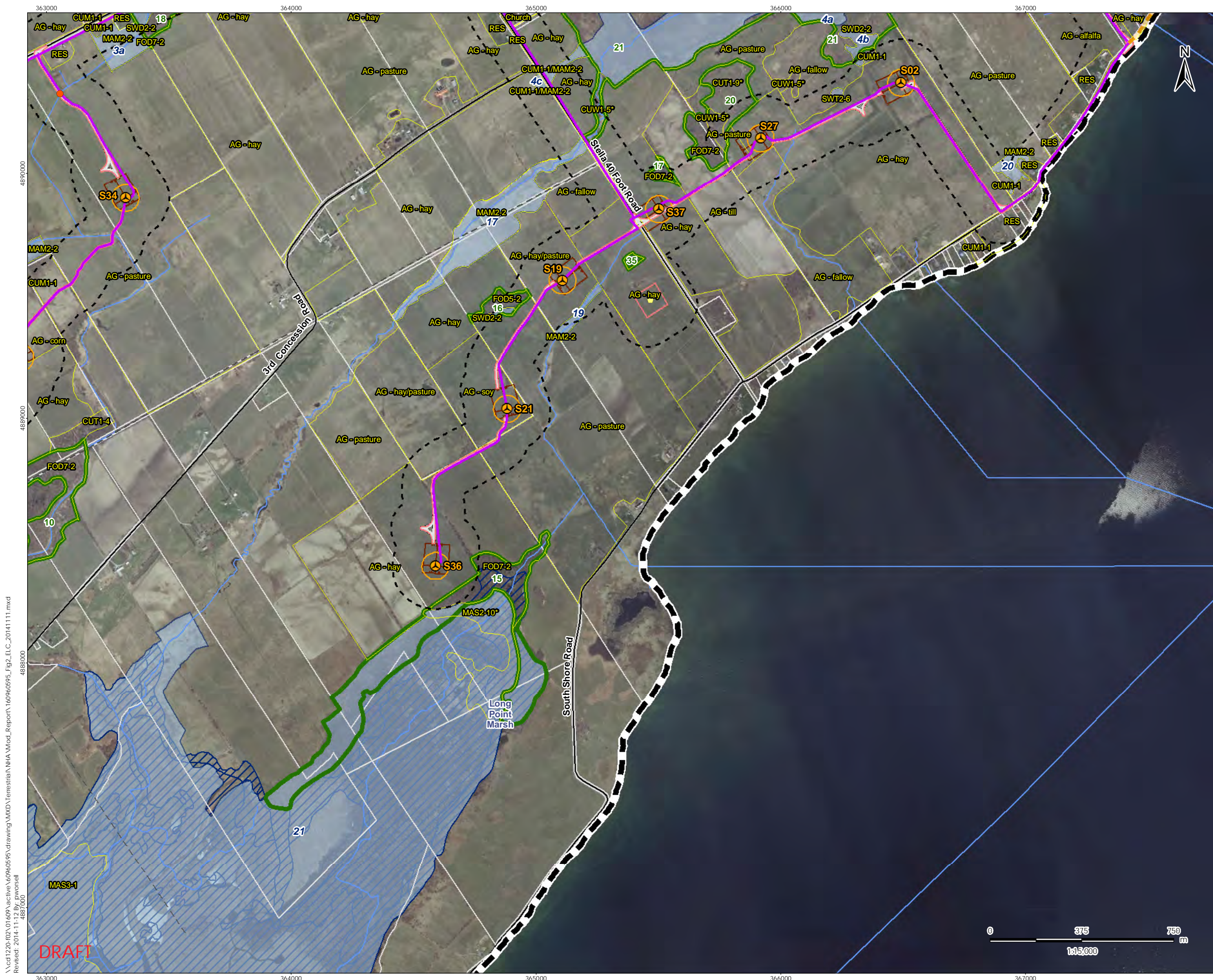

- Legend**
- Study Area
 - 120m Zone of Investigation
 - Project Components
 - Turbine
 - Met Tower (Potential Location)
 - Access Road
 - Collector Line
 - Collector Line (New)
 - Collector Line (Removed)
 - Submarine Cable Path
 - Laydown Area and Crane Pad
 - Operation and Maintenance Building (Potential Location)
 - Turbine Blade Tip
 - Substation (Potential Location)
 - Potential Culvert Location
 - Point of Common Coupling
 - Mainland Cable Vault (Potential Location)
 - Island Cable Vault
 - Aboveground Storage Tanks (Potential Location)
 - Constructible Area
 - Mainland Dock (Potential Location)
 - Island Dock
 - Batch Plant (Potential Location)
 - Site Office (Potential Location)
 - Storage Shed
 - Transmission Lines
 - Mainland Option1
 - Mainland Option 2
 - Island Transmission Line
 - Land Use
 - Central Staging Area
 - Switching Station (Potential Location)
 - Existing Features
 - Road
 - Unopened Road Allowance
 - Railway
 - Hydro Line
 - Watercourse
 - Property Line
 - Provincially Significant Wetland (MNR)
 - Woodland Delineation (Stantec)
 - Wetland Delineation (Stantec)
 - ELC Boundary

Notes

- Coordinate System: NAD 1983 UTM Zone 18N
- Base features produced under license with the Ontario Ministry of Natural Resources © Queen's Printer for Ontario, 2014.
- Orthoimagery © First Base Solutions, 2014. Imagery taken in 2008.

November 2014
160960595

Client/Project
Windlectric Inc.
Amherst Island Wind Energy Project

Figure No.
2.5 **DRAFT**

Title
ELC Vegetation Communities &
Woodland/Wetland Natural
Features



\\cd1220-02\01609\active\60960595\drawing\MXD\Terrestrial\NHA\Mod_Report\160960595_Fig2_ELC_20141111.mxd
 Revised: 2014-11-12 By: pwnorsell
 4887000

DRAFT

Legend

- Study Area
- 120m Zone of Investigation
- Project Components**
- Turbine
- Met Tower (Potential Location)
- Substation (Potential Location)
- Access Road
- Collector Line (New)
- Collector Line (Removed)
- Submarine Cable Path
- Laydown Area and Crane Pad
- Operation and Maintenance Building (Potential Location)
- Potential Culvert Location
- Point of Common Coupling
- Mainland Cable Vault (Potential Location)
- Island Cable Vault
- Aboveground Storage Tanks (Potential Location)
- Constructible Area
- Mainland Dock (Potential Location)
- Island Dock
- Batch Plant (Potential Location)
- Site Office (Potential Location)
- Storage Shed
- Transmission Lines**
- Mainland Option 1
- Mainland Option 2
- Island Transmission Line
- Land Use**
- Central Staging Area
- Switching Station (Potential Location)
- Existing Features**
- Road
- Unopened Road Allowance
- Railway
- Hydro Line
- Watercourse
- Waterbody
- Property Line
- Candidate Significant Wildlife Habitat Features**
- Snake Hibernacula (SN)
- Louisiana Waterthrush Habitat (LW)
- Waterfowl Nesting Area (WN)
- Woodland Raptor Nesting Area (WR)
- Shorebird Migratory Stopover (SM)
- Wilson's Phalarope (WP)
- Bald Eagle Nesting, Foraging, and Perching Habitat (BE)
- Amphibian Breeding (ABWO & ABWE)
- Area-Sensitive Breeding Bird (ABB)
- Colonially-Nesting Birds - Trees/Shrubs (CNB)
- Marsh Breeding Bird (MBB)
- Shrub/Early Successional Bird Breeding (SSB)
- Turtle Overwintering (TO)
- Landbird Migratory Stopover Area (ML)
- Migratory Butterfly Stopover Area (MB)
- Waterfowl Stopover & Staging - Aquatic (WA)
- Waterfowl Stopover & Staging - Terrestrial (WT)
- Old Growth Forest (OGF)

Notes

1. Coordinate System: NAD 1983 UTM Zone 18N
2. Base features produced under license with the Ontario Ministry of Natural Resources © Queen's Printer for Ontario, 2014.

November 2014
160960595

Client/Project

Windlectric Inc.
Amherst Island Wind Energy Project

Figure No.

3.0

DRAFT

Title

Candidate Significant Natural
Features & Wildlife Habitat -
Overview

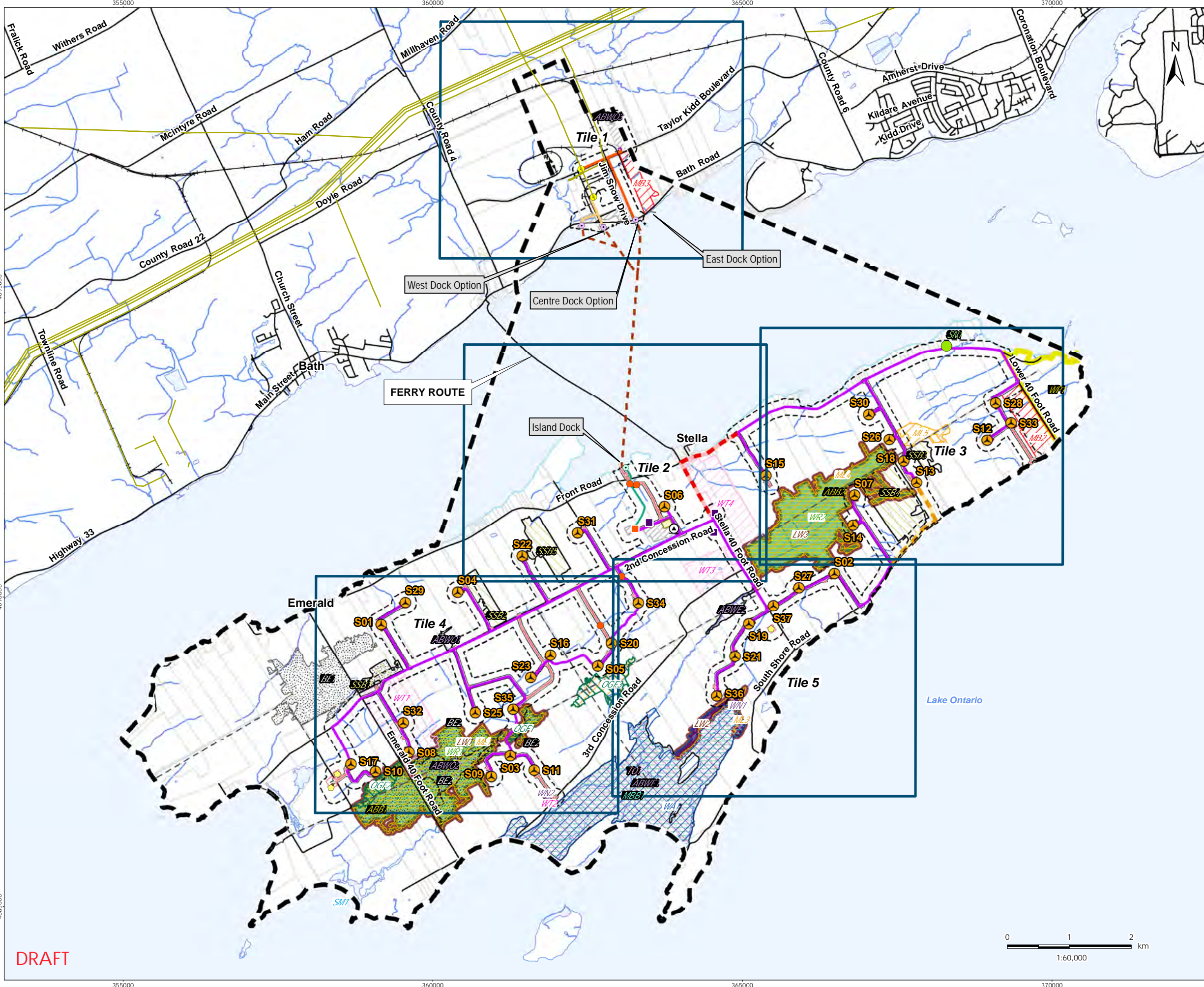

DRAFT

\\cd1220-102\01609\active\60960595\drawing\MXD\Terrestrial\NHA\Wood_Report\160960595_Fig3_CandidateSignificantWildlifeHabitat_Overview_20141111.mxd
 Revised: 2014-11-11 By: p.worsell
 4885000

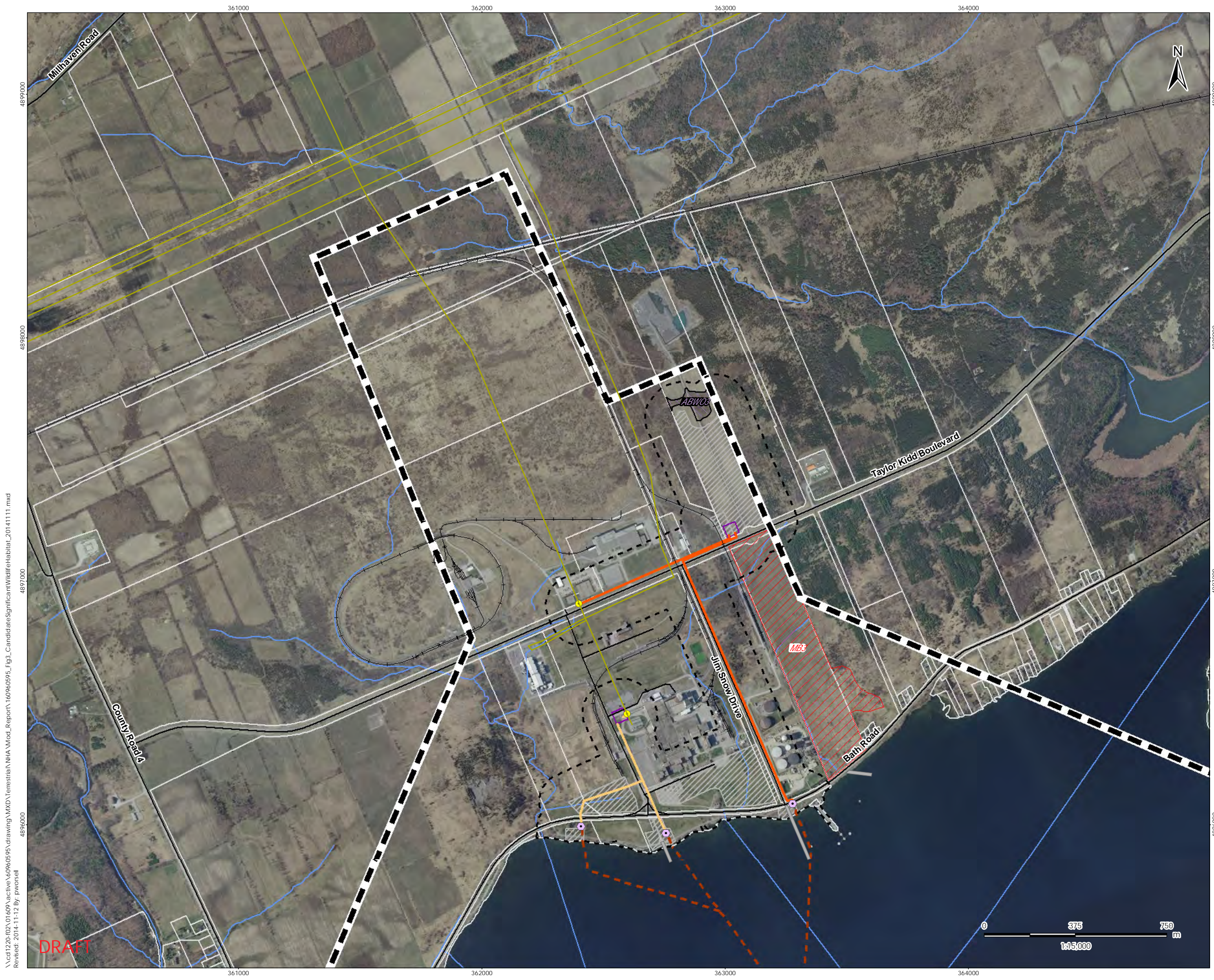

- Legend**
- Study Area
 - 120m Zone of Investigation
 - Project Components**
 - Turbine
 - Met Tower (Potential Location)
 - Access Road
 - Collector Line
 - Collector Line (New)
 - Collector Line (Removed)
 - Submarine Cable Path
 - Laydown Area and Crane Pad
 - Operation and Maintenance Building (Potential Location)
 - Turbine Blade Tip
 - Substation (Potential Location)
 - Potential Culvert Location
 - Point of Common Coupling
 - Mainland Cable Vault (Potential Location)
 - Island Cable Vault
 - Aboveground Storage Tanks (Potential Location)
 - Constructible Area
 - Mainland Dock (Potential Location)
 - Island Dock
 - Batch Plant (Potential Location)
 - Site Office (Potential Location)
 - Storage Shed
 - Transmission Lines**
 - Mainland Option 1
 - Mainland Option 2
 - Island Transmission Line
 - Land Use**
 - Central Staging Area
 - Switching Station (Potential Location)
 - Existing Features**
 - Road
 - Unopened Road Allowance
 - Railway
 - Hydro Line
 - Watercourse
 - Property Line
 - Candidate Significant Wildlife Habitat Features**
 - Snake Hibernacula (SN)
 - Amphibian Breeding (ABWO & ABWE)
 - Area-Sensitive Breeding Bird (ABB)
 - Marsh Breeding Bird (MBB)
 - Shrub/Early Successional Bird Breeding (SSB)
 - Turtle Overwintering (TO)
 - Louisiana Waterthrush Habitat (LW)
 - Waterfowl Nesting Area (WN)
 - Woodland Raptor Nesting Area (WR)
 - Shorebird Migratory Stopover (SM)
 - Bald Eagle Nesting, Foraging, and Perching Habitat (BE)
 - Landbird Migratory Stopover Area (ML)
 - Migratory Butterfly Stopover Area (MB)
 - Waterfowl Stopover & Staging - Aquatic (WA)
 - Waterfowl Stopover & Staging - Terrestrial (WT)
 - Old Growth Forest (OGF)
 - Wilson's Phalarope (WP)

- Notes**
1. Coordinate System: NAD 1983 UTM Zone 18N
 2. Base features produced under license with the Ontario Ministry of Natural Resources © Queen's Printer for Ontario, 2014.
 3. Orthoimagery © First Base Solutions, 2014. Imagery taken in 2008.

November 2014
160960595

Client/Project
Windlectric Inc.
Amherst Island Wind Energy Project

Figure No.
3.1 **DRAFT**

Title
Candidate Significant Natural
Features & Wildlife Habitat



\\cd1220-102\01609\active\60960595\drawing\MXD\Terrestrial\NHA\Mod_Report\160960595_Fig3_CandidateSignificantWildlifeHabitat_20141111.mxd
 Revised: 2014-11-12 By: pworsell

DRAFT

361000 362000 363000 364000 365000

4894000
4893000
4892000
4891000



Legend

- Study Area
- 120m Zone of Investigation
- Project Components
 - Turbine
 - Met Tower (Potential Location)
 - Access Road
 - Collector Line
 - Collector Line (New)
 - Collector Line (Removed)
 - Submarine Cable Path
 - Laydown Area and Crane Pad
 - Operation and Maintenance Building (Potential Location)
 - Turbine Blade Tip
 - Substation (Potential Location)
 - Potential Culvert Location
 - Point of Common Coupling
 - Mainland Cable Vault (Potential Location)
 - Island Cable Vault
 - Aboveground Storage Tanks (Potential Location)
- Constructible Area
- Mainland Dock (Potential Location)
- Island Dock
- Batch Plant (Potential Location)
- Site Office (Potential Location)
- Storage Shed
- Transmission Lines
 - Mainland Option1
 - Mainland Option 2
 - Island Transmission Line
- Land Use
 - Central Staging Area
 - Switching Station (Potential Location)
- Existing Features
 - Road
 - Unopened Road Allowance
 - Railway
 - Hydro Line
 - Watercourse
 - Property Line
- Candidate Significant Wildlife Habitat Features
 - Snake Hibernacula (SN)
 - Amphibian Breeding (ABWO & ABWE)
 - Area-Sensitive Breeding Bird (ABB)
 - Marsh Breeding Bird (MBB)
 - Shrub/Early Successional Bird Breeding (SSB)
 - Turtle Overwintering (TO)
 - Louisiana Waterthrush Habitat (LW)
 - Waterfowl Nesting Area (WN)
 - Woodland Raptor Nesting Area (WR)
 - Shorebird Migratory Stopover (SM)
 - Bald Eagle Nesting, Foraging, and Perching Habitat (BE)
 - Landbird Migratory Stopover Area (ML)
 - Migratory Butterfly Stopover Area (MB)
 - Waterfowl Stopover & Staging - Aquatic (WA)
 - Waterfowl Stopover & Staging - Terrestrial (WT)
 - Old Growth Forest (OGF)
 - Wilson's Phalarope (WP)

Notes

- Coordinate System: NAD 1983 UTM Zone 18N
- Base features produced under license with the Ontario Ministry of Natural Resources © Queen's Printer for Ontario, 2014.
- Orthoimagery © First Base Solutions, 2014. Imagery taken in 2008.

November 2014
160960595

Client/Project

Windlectric Inc.
Amherst Island Wind Energy Project

Figure No.

3.2

DRAFT

Title

Candidate Significant Natural
Features & Wildlife Habitat

361000 362000 363000 364000 365000

DRAFT

\\cd1220-02\01609\active\60960595\drawing\MXD\Terrestrial\NHA\Mod_Report\160960595_Fig3_CandidateSignificantWildlifeHabitat_20141111.mxd
Revised: 2014-11-12 By: pwnorsell



Legend

- Study Area
- 120m Zone of Investigation
- Project Components
 - Turbine
 - Met Tower (Potential Location)
 - Access Road
 - Collector Line
 - Collector Line (New)
 - Collector Line (Removed)
 - Submarine Cable Path
 - Laydown Area and Crane Pad
 - Operation and Maintenance Building (Potential Location)
 - Turbine Blade Tip
 - Substation (Potential Location)
 - Potential Culvert Location
 - Point of Common Coupling
 - Mainland Cable Vault (Potential Location)
 - Island Cable Vault
 - Aboveground Storage Tanks (Potential Location)
- Constructible Area
- Mainland Dock (Potential Location)
- Island Dock
- Batch Plant (Potential Location)
- Site Office (Potential Location)
- Storage Shed
- Transmission Lines
 - Mainland Option 1
 - Mainland Option 2
 - Island Transmission Line
- Land Use
 - Central Staging Area
 - Switching Station (Potential Location)
- Existing Features
 - Road
 - Unopened Road Allowance
 - Railway
 - Hydro Line
 - Watercourse
 - Property Line
- Candidate Significant Wildlife Habitat Features
 - Snake Hibernacula (SN)
 - Amphibian Breeding (ABW & ABWE)
 - Area-Sensitive Breeding Bird (ABB)
 - Marsh Breeding Bird (MBB)
 - Shrub/Early Successional Bird Breeding (SSB)
 - Turtle Overwintering (TO)
 - Louisiana Waterthrush Habitat (LW)
 - Waterfowl Nesting Area (WN)
 - Woodland Raptor Nesting Area (WR)
 - Shorebird Migratory Stopover (SM)
 - Bald Eagle Nesting, Foraging, and Perching Habitat (BE)
 - Landbird Migratory Stopover Area (ML)
 - Migratory Butterfly Stopover Area (MB)
 - Waterfowl Stopover & Staging - Aquatic (WA)
 - Waterfowl Stopover & Staging - Terrestrial (WT)
 - Old Growth Forest (OGF)
 - Wilson's Phalarope (WP)

Notes

- Coordinate System: NAD 1983 UTM Zone 18N
- Base features produced under license with the Ontario Ministry of Natural Resources © Queen's Printer for Ontario, 2014.
- Orthoimagery © First Base Solutions, 2014. Imagery taken in 2008.

November 2014
160960595

Client/Project
Windlectric Inc.
Amherst Island Wind Energy Project

Figure No.
3.3 **DRAFT**

Title
Candidate Significant Natural
Features & Wildlife Habitat

\\cd1220-102\01609\active\60960595\drawing\MXD\Terrestrial\NHA\Wood_Report\160960595_Fig3_CandidateSignificantWildlifeHabitat_20141111.mxd
Revised: 2014-11-12 By: pworsell

DRAFT

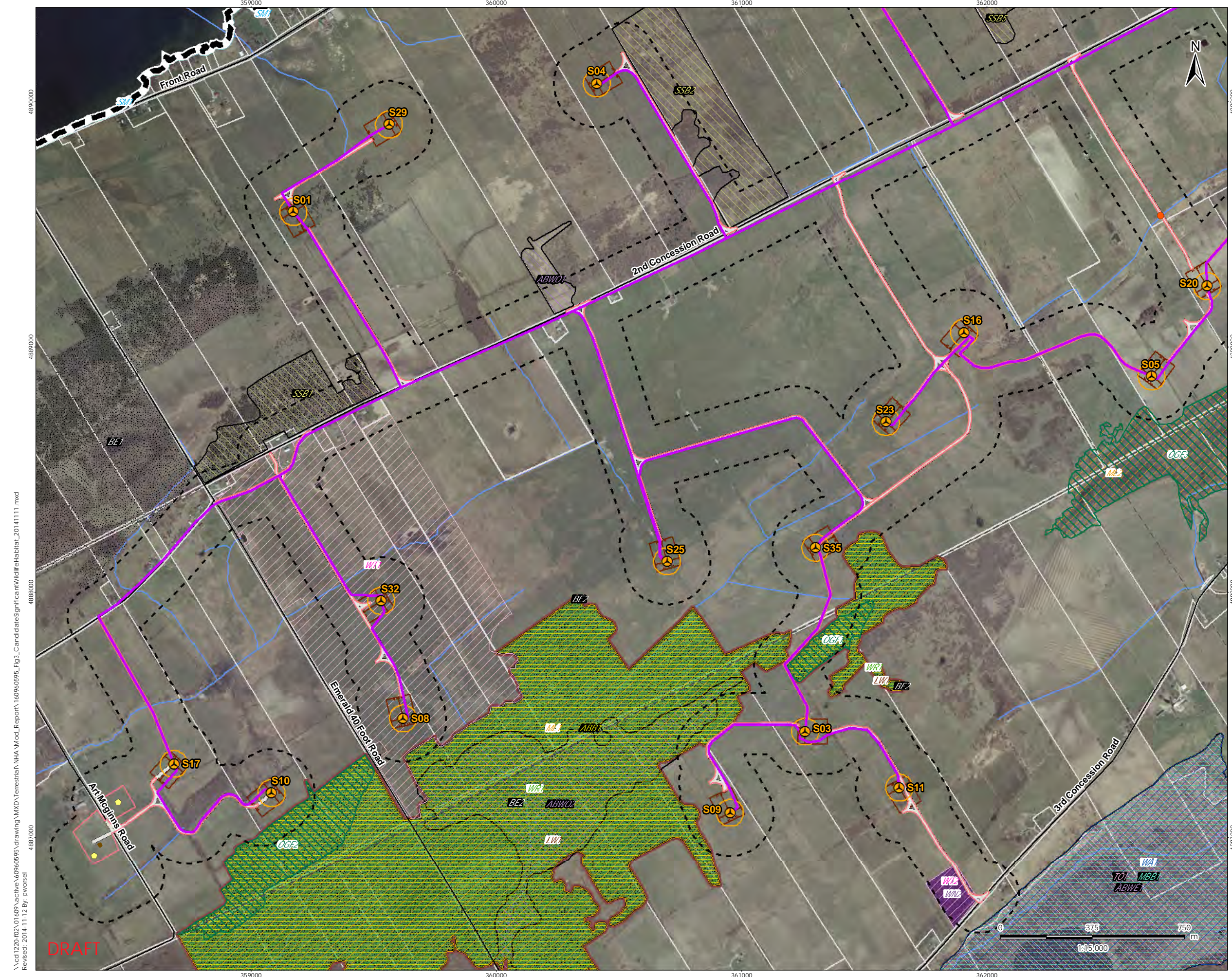

- Legend**
- Study Area
 - 120m Zone of Investigation
 - Project Components
 - Turbine
 - Met Tower (Potential Location)
 - Access Road
 - Collector Line
 - Collector Line (New)
 - Collector Line (Removed)
 - Submarine Cable Path
 - Laydown Area and Crane Pad
 - Operation and Maintenance Building (Potential Location)
 - Turbine Blade Tip
 - Substation (Potential Location)
 - Potential Culvert Location
 - Point of Common Coupling
 - Mainland Cable Vault (Potential Location)
 - Island Cable Vault
 - Aboveground Storage Tanks (Potential Location)
 - Constructible Area
 - Mainland Dock (Potential Location)
 - Island Dock
 - Batch Plant (Potential Location)
 - Site Office (Potential Location)
 - Storage Shed
 - Transmission Lines
 - Mainland Option 1
 - Mainland Option 2
 - Island Transmission Line
 - Land Use
 - Central Staging Area
 - Switching Station (Potential Location)
 - Existing Features
 - Road
 - Unopened Road Allowance
 - Railway
 - Hydro Line
 - Watercourse
 - Property Line
 - Candidate Significant Wildlife Habitat Features
 - Snake Hibernacula (SN)
 - Amphibian Breeding (ABWO & ABWE)
 - Area-Sensitive Breeding Bird (ABB)
 - Marsh Breeding Bird (MBB)
 - Shrub/Early Successional Bird Breeding (SSB)
 - Turtle Overwintering (TO)
 - Louisiana Waterthrush Habitat (LW)
 - Waterfowl Nesting Area (WN)
 - Woodland Raptor Nesting Area (WR)
 - Shorebird Migratory Stopover (SM)
 - Bald Eagle Nesting, Foraging, and Perching Habitat (BE)
 - Landbird Migratory Stopover Area (ML)
 - Migratory Butterfly Stopover Area (MB)
 - Waterfowl Stopover & Staging - Aquatic (WA)
 - Waterfowl Stopover & Staging - Terrestrial (WT)
 - Old Growth Forest (OGF)
 - Wilson's Phalarope (WP)

- Notes**
- Coordinate System: NAD 1983 UTM Zone 18N
 - Base features produced under license with the Ontario Ministry of Natural Resources © Queen's Printer for Ontario, 2014.
 - Orthoimagery © First Base Solutions, 2014. Imagery taken in 2008.

November 2014
160960595

Client/Project
Windlectric Inc.
Amherst Island Wind Energy Project

Figure No.
3.4 **DRAFT**

Title
Candidate Significant Natural Features & Wildlife Habitat

\\cd1220-102\01609\active\60960595\drawing\MXD\Terrestrial\NHA\Mod_Report\160960595_Fig3_CandidateSignificantWildlifeHabitat_20141111.mxd
 Revised: 2014-11-12 By: pworsell

DRAFT



- Legend**
- Study Area
 - 120m Zone of Investigation
 - Project Components
 - Turbine
 - Met Tower (Potential Location)
 - Access Road
 - Collector Line
 - Collector Line (New)
 - Collector Line (Removed)
 - Submarine Cable Path
 - Laydown Area and Crane Pad
 - Operation and Maintenance Building (Potential Location)
 - Turbine Blade Tip
 - Substation (Potential Location)
 - Potential Culvert Location
 - Point of Common Coupling
 - Mainland Cable Vault (Potential Location)
 - Island Cable Vault
 - Aboveground Storage Tanks (Potential Location)
 - Constructible Area
 - Mainland Dock (Potential Location)
 - Island Dock
 - Batch Plant (Potential Location)
 - Site Office (Potential Location)
 - Storage Shed
 - Transmission Lines
 - Mainland Option 1
 - Mainland Option 2
 - Island Transmission Line
 - Land Use
 - Central Staging Area
 - Switching Station (Potential Location)
 - Existing Features
 - Road
 - Unopened Road Allowance
 - Railway
 - Hydro Line
 - Watercourse
 - Property Line
 - Candidate Significant Wildlife Habitat Features
 - Snake Hibernacula (SN)
 - Amphibian Breeding (ABWO & ABWE)
 - Area-Sensitive Breeding Bird (ABB)
 - Marsh Breeding Bird (MBB)
 - Shrub/Early Successional Bird Breeding (SSB)
 - Turtle Overwintering (TO)
 - Louisiana Waterthrush Habitat (LW)
 - Waterfowl Nesting Area (WN)
 - Woodland Raptor Nesting Area (WR)
 - Shorebird Migratory Stopover (SM)
 - Bald Eagle Nesting, Foraging, and Perching Habitat (BE)
 - Landbird Migratory Stopover Area (ML)
 - Migratory Butterfly Stopover Area (MB)
 - Waterfowl Stopover & Staging - Aquatic (WA)
 - Waterfowl Stopover & Staging - Terrestrial (WT)
 - Old Growth Forest (OGF)
 - Wilson's Phalarope (WP)

- Notes**
- Coordinate System: NAD 1983 UTM Zone 18N
 - Base features produced under license with the Ontario Ministry of Natural Resources © Queen's Printer for Ontario, 2014.
 - Orthoimagery © First Base Solutions, 2014. Imagery taken in 2008.

November 2014
160960595

Client/Project
Windlectric Inc.
Amherst Island Wind Energy Project

Figure No.
3.5 **DRAFT**

Title
Candidate Significant Natural
Features & Wildlife Habitat



\\cd1220-102\01609\active\60960595\drawing\MXD\Terrestrial\NHA\Mod_Report\160960595_Fig3_CandidateSignificantWildlifeHabitat_20141111.mxd
 Revised: 2014-11-12 By: p.worsell
 4887000

DRAFT



- Legend**
- Study Area
 - 120m Zone of Investigation
 - Project Components**
 - Turbine
 - Met Tower (Potential Location)
 - Access Road
 - Collector Line
 - Collector Line (New)
 - Collector Line (Removed)
 - Submarine Cable Path
 - Laydown Area and Crane Pad
 - Operation and Maintenance Building (Potential Location)
 - Turbine Blade Tip
 - Substation (Potential Location)
 - Potential Culvert Location
 - Point of Common Coupling
 - Mainland Cable Vault (Potential Location)
 - Island Cable Vault
 - Aboveground Storage Tanks (Potential Location)
 - Constructible Area
 - Mainland Dock (Potential Location)
 - Island Dock
 - Batch Plant (Potential Location)
 - Site Office (Potential Location)
 - Storage Shed
 - Transmission Lines**
 - Mainland Option 1
 - Mainland Option 2
 - Island Transmission Line
 - Land Use**
 - Central Staging Area
 - Switching Station (Potential Location)
 - Existing Features**
 - Road
 - Unopened Road Allowance
 - Railway
 - Hydro Line
 - Watercourse
 - Property Line
 - Open Country Breeding Bird Area (OCB)
(OCB habitats are transparent with hatching)
 - Raptor Wintering Area (RWA)

Notes

- Coordinate System: NAD 1983 UTM Zone 18N
- Base features produced under license with the Ontario Ministry of Natural Resources © Queen's Printer for Ontario, 2014.
- Orthoimagery © First Base Solutions, 2014. Imagery taken in 2008.

November 2014
160960595

Client/Project
Windlectric Inc.
Amherst Island Wind Energy Project

Figure No.
4.1 **DRAFT**

Title
Candidate Open Country Breeding Bird & Raptor Wintering Areas



\\cd1220-102\01609\active\60960595\drawing\MXD\Terrestrial\NHA\Mod_Report\160960595_Fig4_CandidateRWA_OCB_20141111.mxd
 Revised: 2014-11-12 By: pworsell

DRAFT

361000 362000 363000 364000 365000

4894000

4893000

4892000

4891000

4890000



- Legend**
- Study Area
 - 120m Zone of Investigation
 - Project Components**
 - Turbine
 - Met Tower (Potential Location)
 - Access Road
 - Collector Line
 - Collector Line (New)
 - Collector Line (Removed)
 - Submarine Cable Path
 - Laydown Area and Crane Pad
 - Operation and Maintenance Building (Potential Location)
 - Turbine Blade Tip
 - Substation (Potential Location)
 - Potential Culvert Location
 - Point of Common Coupling
 - Mainland Cable Vault (Potential Location)
 - Island Cable Vault
 - Aboveground Storage Tanks (Potential Location)
 - Constructible Area
 - Mainland Dock (Potential Location)
 - Island Dock
 - Batch Plant (Potential Location)
 - Site Office (Potential Location)
 - Storage Shed
 - Transmission Lines**
 - Mainland Option 1
 - Mainland Option 2
 - Island Transmission Line
 - Land Use**
 - Central Staging Area
 - Switching Station (Potential Location)
 - Existing Features**
 - Road
 - Unopened Road Allowance
 - Railway
 - Hydro Line
 - Watercourse
 - Property Line
 - Open Country Breeding Bird Area (OCB) (OCB habitats are transparent with hatching)
 - Raptor Wintering Area (RWA)



- Notes**
- Coordinate System: NAD 1983 UTM Zone 18N
 - Base features produced under license with the Ontario Ministry of Natural Resources © Queen's Printer for Ontario, 2014.
 - Orthoimagery © First Base Solutions, 2014. Imagery taken in 2008.

November 2014
160960595

Client/Project
Windlectric Inc.
Amherst Island Wind Energy Project

Figure No.
4.2 **DRAFT**

Title
Candidate Open Country Breeding Bird & Raptor Wintering Areas

\\cd1220-02\01609\active\60960595\drawing\MXD\Terrestrial\NHA\Mod_Report\160960595_Fig4_CandidateRWA_OCB_20141111.mxd
Revised: 2014-11-12 By: pworsell

DRAFT





- Legend**
- Study Area
 - 120m Zone of Investigation
 - Project Components**
 - Turbine
 - Met Tower (Potential Location)
 - Access Road
 - Collector Line
 - Collector Line (New)
 - Collector Line (Removed)
 - Submarine Cable Path
 - Laydown Area and Crane Pad
 - Operation and Maintenance Building (Potential Location)
 - Turbine Blade Tip
 - Substation (Potential Location)
 - Potential Culvert Location
 - Point of Common Coupling
 - Mainland Cable Vault (Potential Location)
 - Island Cable Vault
 - Aboveground Storage Tanks (Potential Location)
 - Constructible Area
 - Mainland Dock (Potential Location)
 - Island Dock
 - Batch Plant (Potential Location)
 - Site Office (Potential Location)
 - Storage Shed
 - Transmission Lines**
 - Mainland Option1
 - Mainland Option 2
 - Island Transmission Line
 - Land Use**
 - Central Staging Area
 - Switching Station (Potential Location)
 - Existing Features**
 - Road
 - Unopened Road Allowance
 - Railway
 - Hydro Line
 - Watercourse
 - Property Line
 - Open Country Breeding Bird Area (OCB) (OCB habitats are transparent with hatching)
 - Raptor Wintering Area (RWA)

Notes

- Coordinate System: NAD 1983 UTM Zone 18N
- Base features produced under license with the Ontario Ministry of Natural Resources © Queen's Printer for Ontario, 2014.
- Orthoimagery © First Base Solutions, 2014. Imagery taken in 2008.

November 2014
160960595

Client/Project
Windlectric Inc.
Amherst Island Wind Energy Project

Figure No.
4.3 **DRAFT**

Title
Candidate Open Country Breeding Bird & Raptor Wintering Areas



\\cd1220-102\01609\active\60960595\drawing\MXD\Terrestrial\NHA\Mod_Report\160960595_Fig4_CandidateRWA_OCB_20141111.mxd
 Revised: 2014-11-12 By: pwnorsell

DRAFT

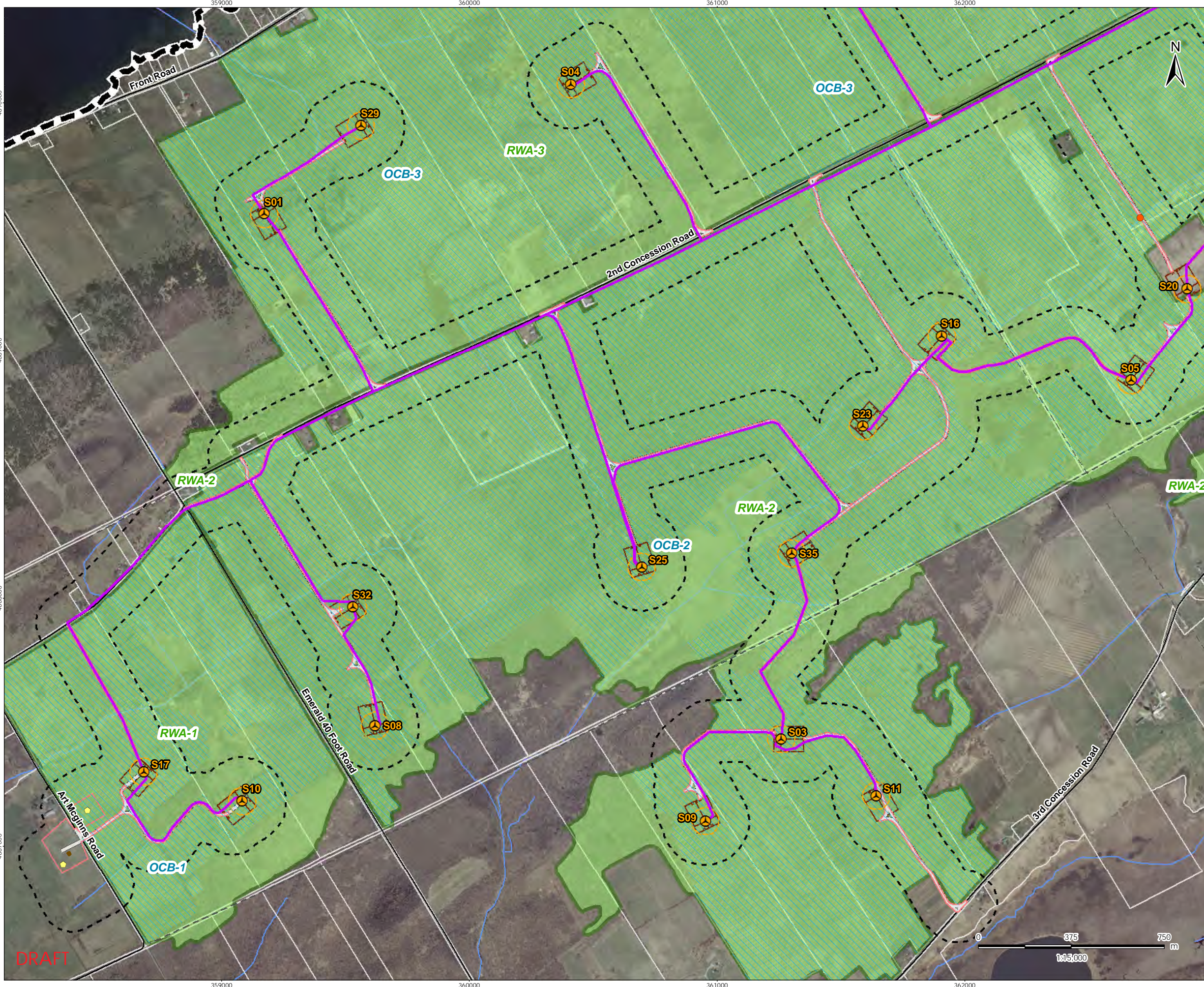

- Legend**
- Study Area
 - 120m Zone of Investigation
 - Project Components**
 - Turbine
 - Met Tower (Potential Location)
 - Access Road
 - Collector Line
 - Collector Line (New)
 - Collector Line (Removed)
 - Submarine Cable Path
 - Laydown Area and Crane Pad
 - Operation and Maintenance Building (Potential Location)
 - Turbine Blade Tip
 - Substation (Potential Location)
 - Potential Culvert Location
 - Point of Common Coupling
 - Mainland Cable Vault (Potential Location)
 - Island Cable Vault
 - Aboveground Storage Tanks (Potential Location)
 - Constructible Area
 - Mainland Dock (Potential Location)
 - Island Dock
 - Batch Plant (Potential Location)
 - Site Office (Potential Location)
 - Storage Shed
 - Transmission Lines**
 - Mainland Option1
 - Mainland Option 2
 - Island Transmission Line
 - Land Use**
 - Central Staging Area
 - Switching Station (Potential Location)
 - Existing Features**
 - Road
 - Unopened Road Allowance
 - Railway
 - Hydro Line
 - Watercourse
 - Property Line
 - Open Country Breeding Bird Area (OCB) (OCB habitats are transparent with hatching)
 - Raptor Wintering Area (RWA)

- Notes**
- Coordinate System: NAD 1983 UTM Zone 18N
 - Base features produced under license with the Ontario Ministry of Natural Resources © Queen's Printer for Ontario, 2014.
 - Orthoimagery © First Base Solutions, 2014. Imagery taken in 2008.

November 2014
160960595

Client/Project
Windlectric Inc.
Amherst Island Wind Energy Project

Figure No.
4.4 **DRAFT**

Title
Candidate Open Country Breeding Bird & Raptor Wintering Areas

\\cd1220-102\01609\active\60960595\drawing\MXD\Terrestrial\NHA\Mod_Report\160960595_Fig4_CandidateRWA_OCB_20141111.mxd
 Revised: 2014-11-12 By: pwnorsell

DRAFT



- Legend**
- Study Area
 - 120m Zone of Investigation
 - Project Components**
 - Turbine
 - Met Tower (Potential Location)
 - Access Road
 - Collector Line
 - Collector Line (New)
 - Collector Line (Removed)
 - Submarine Cable Path
 - Laydown Area and Crane Pad
 - Operation and Maintenance Building (Potential Location)
 - Turbine Blade Tip
 - Substation (Potential Location)
 - Potential Culvert Location
 - Point of Common Coupling
 - Mainland Cable Vault (Potential Location)
 - Island Cable Vault
 - Aboveground Storage Tanks (Potential Location)
 - Constructible Area
 - Mainland Dock (Potential Location)
 - Island Dock
 - Batch Plant (Potential Location)
 - Site Office (Potential Location)
 - Storage Shed
 - Transmission Lines**
 - Mainland Option 1
 - Mainland Option 2
 - Island Transmission Line
 - Land Use**
 - Central Staging Area
 - Switching Station (Potential Location)
 - Existing Features**
 - Road
 - Unopened Road Allowance
 - Railway
 - Hydro Line
 - Watercourse
 - Property Line
 - Open Country Breeding Bird Area (OCB)
(OCB habitats are transparent with hatching)
 - Raptor Wintering Area (RWA)

- Notes**
1. Coordinate System: NAD 1983 UTM Zone 18N
 2. Base features produced under license with the Ontario Ministry of Natural Resources © Queen's Printer for Ontario, 2014.
 3. Orthoimagery © First Base Solutions, 2014. Imagery taken in 2008.

November 2014
160960595

Client/Project
Windlectric Inc.
Amherst Island Wind Energy Project

Figure No.
4.5 **DRAFT**

Title
Candidate Open Country Breeding Bird & Raptor Wintering Areas



\\cd1220-102\01609\active\60960595\drawing\MXD\Terrestrial\NHA\Mod_Report\160960595_Fig4_CandidateRWA_OCB_20141111.mxd
 Revised: 2014-11-12 By: pwnorsell
 4887000

DRAFT

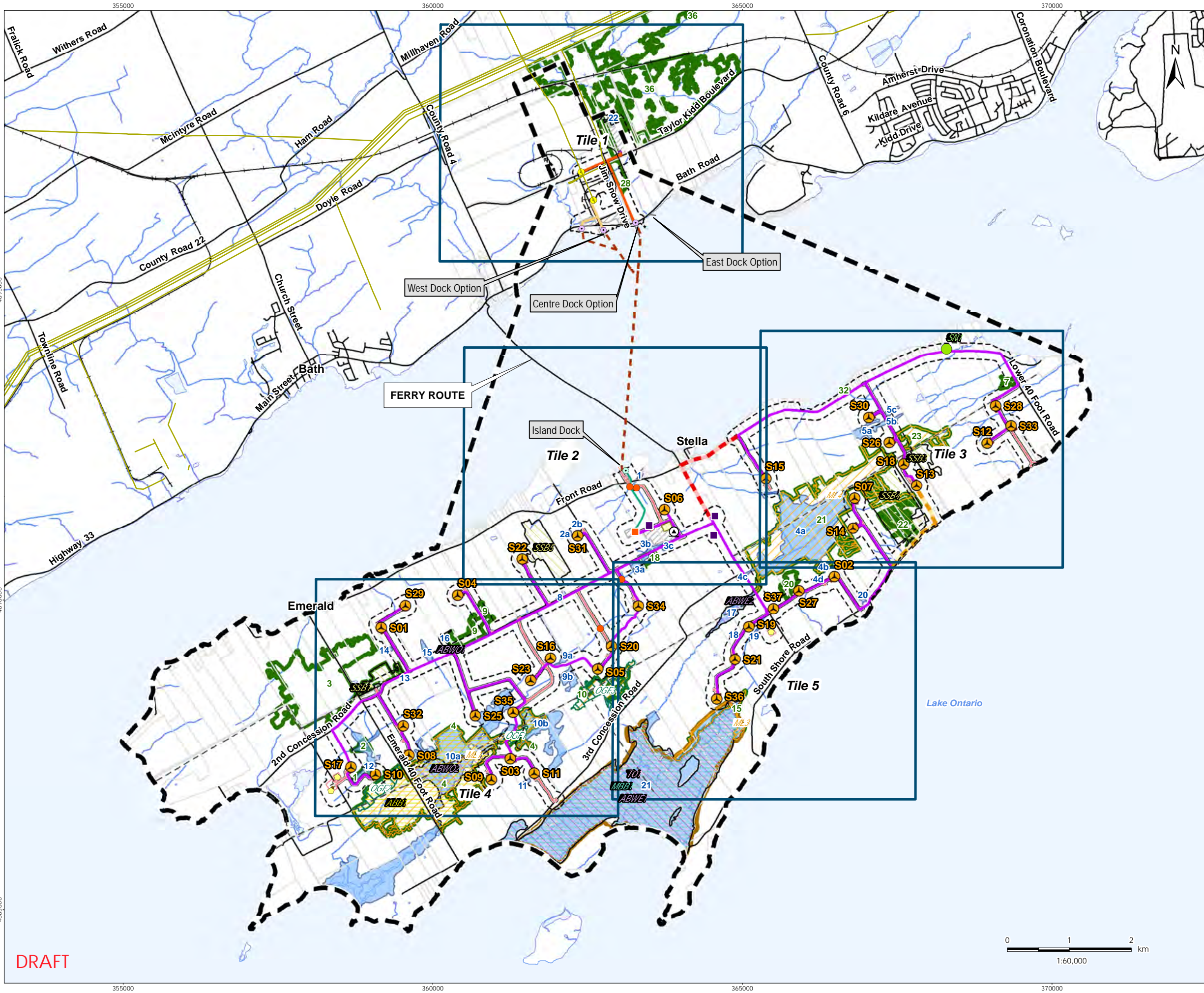

- Legend**
- Study Area
 - 120m Zone of Investigation
 - Project Components**
 - Turbine
 - Met Tower (Potential Location)
 - Substation (Potential Location)
 - Access Road
 - Collector Line
 - Collector Line (New)
 - Collector Line (Removed)
 - Submarine Cable Path
 - Laydown Area and Crane Pad
 - Operation and Maintenance Building (Potential Location)
 - Potential Culvert Location
 - Point of Common Coupling
 - Mainland Cable Vault (Potential Location)
 - Island Cable Vault
 - Aboveground Storage Tanks (Potential Location)
 - Constructible Area
 - Mainland Dock (Potential Location)
 - Island Dock
 - Batch Plant (Potential Location)
 - Site Office (Potential Location)
 - Storage Shed
 - Transmission Lines**
 - Mainland Option 1
 - Mainland Option 2
 - Island Transmission Line
 - Land Use**
 - Central Staging Area
 - Switching Station (Potential Location)
 - Existing Features**
 - Road
 - Unopened Road Allowance
 - Railway
 - Hydro Line
 - Watercourse
 - Waterbody
 - Amherst Bay Life Science ANSI
 - Property Line
 - Significant Wildlife Habitat Features**
 - Snake Hibernacula (SN)
 - Amphibian Breeding (ABWO & ABWE)
 - Area-Sensitive Breeding Bird (ABB)
 - Marsh Breeding Bird (MBB)
 - Shrub/Early Successional Bird Breeding (SSB)
 - Turtle Overwintering (TO)
 - Landbird Migratory Stopover Area (ML)
 - Waterfowl Stopover & Staging - Terrestrial (WT)
 - Old Growth Forest (OGF)
 - Significant Woodland
 - Significant Wetland

Notes

- Coordinate System: NAD 1983 UTM Zone 18N
- Base features produced under license with the Ontario Ministry of Natural Resources © Queen's Printer for Ontario, 2014.

Client/Project
 Windlectric Inc.
 Amherst Island Wind Energy Project

Figure No.
 5.0

Title
 Significant Natural Features & Wildlife Habitat - Overview

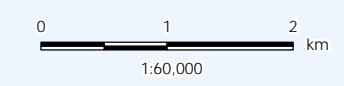

DRAFT

DRAFT

\\cd1220-102\01609\active\60960595\drawing\MXD\Terrestrial\NHA\Mod_Report\160960595_Fig5_SignificantWildlifeHabitat_Overview_20141111.mxd
 Revised: 2014-11-12 By: p.worsell
 4885000



- Legend**
- Study Area
 - 120m Zone of Investigation
 - Project Components**
 - Turbine
 - Met Tower (Potential Location)
 - Access Road
 - Collector Line
 - Collector Line (New)
 - Collector Line (Removed)
 - Submarine Cable Path
 - Laydown Area and Crane Pad
 - Operation and Maintenance Building (Potential Location)
 - Turbine Blade Tip
 - Substation (Potential Location)
 - Potential Culvert Location
 - Potential Common Coupling
 - Mainland Cable Vault (Potential Location)
 - Island Cable Vault
 - Aboveground Storage Tanks (Potential Location)
 - Constructible Area
 - Mainland Dock (Potential Location)
 - Island Dock
 - Batch Plant (Potential Location)
 - Site Office (Potential Location)
 - Storage Shed
 - Transmission Lines**
 - Mainland Option 1
 - Mainland Option 2
 - Island Transmission Line
 - Land Use**
 - Central Staging Area
 - Switching Station (Potential Location)
 - Existing Features**
 - Road
 - Unopened Road Allowance
 - Railway
 - Hydro Line
 - Watercourse
 - Amherst Bay Life Science ANSI
 - Property Line
 - Significant Wildlife Habitat Features**
 - Snake Hibernacula (SN)
 - Amphibian Breeding (ABWO & ABWE)
 - Area-Sensitive Breeding Bird (ABB)
 - Marsh Breeding Bird (MBB)
 - Shrub/Early Successional Bird Breeding (SSB)
 - Turtle Overwintering (TO)
 - Shorebird Migratory Stopover (SM)
 - Landbird Migratory Stopover Area (ML)
 - Waterfowl Stopover & Staging - Terrestrial (WT)
 - Old Growth Forest (OGF)
 - Significant Woodland
 - Significant Wetland

Notes

- Coordinate System: NAD 1983 UTM Zone 18N
- Base features produced under license with the Ontario Ministry of Natural Resources © Queen's Printer for Ontario, 2014.
- Orthoimagery © First Base Solutions, 2014. Imagery taken in 2008.

November 2014
160960595

Client/Project
Windlectric Inc.
Amherst Island Wind Energy Project

Figure No.
5.1 **DRAFT**

Title
Significant Natural Features & Wildlife Habitat



\\cd1220-102\01609\active\60960595\drawing\MXD\Terrestrial\NHA\Mod_Report\160960595_Fig5_SignificantWildlifeHabitat_20141111.mxd
 Revised: 2014-11-12 By: pworesell

DRAFT

361000 362000 363000 364000 365000

4894000
4893000
4892000
4891000



- Legend**
- Study Area
 - 120m Zone of Investigation
 - Project Components**
 - Turbine
 - Met Tower (Potential Location)
 - Access Road
 - Collector Line
 - Collector Line (New)
 - Collector Line (Removed)
 - Submarine Cable Path
 - Laydown Area and Crane Pad
 - Operation and Maintenance Building (Potential Location)
 - Turbine Blade Tip
 - Substation (Potential Location)
 - Potential Culvert Location
 - Point of Common Coupling
 - Mainland Cable Vault (Potential Location)
 - Island Cable Vault
 - Aboveground Storage Tanks (Potential Location)
 - Constructible Area
 - Mainland Dock (Potential Location)
 - Island Dock
 - Batch Plant (Potential Location)
 - Site Office (Potential Location)
 - Storage Shed
 - Transmission Lines**
 - Mainland Option 1
 - Mainland Option 2
 - Island Transmission Line
 - Land Use**
 - Central Staging Area
 - Switching Station (Potential Location)
 - Existing Features**
 - Road
 - Unopened Road Allowance
 - Railway
 - Hydro Line
 - Watercourse
 - Amherst Bay Life Science ANSI
 - Property Line
 - Significant Wildlife Habitat Features**
 - Snake Hibernacula (SN)
 - Amphibian Breeding (ABWO & ABWE)
 - Area-Sensitive Breeding Bird (ABB)
 - Marsh Breeding Bird (MBB)
 - Shrub/Early Successional Bird Breeding (SSB)
 - Turtle Overwintering (TO)
 - Shorebird Migratory Stopover (SM)
 - Landbird Migratory Stopover Area (ML)
 - Waterfowl Stopover & Staging - Terrestrial (WT)
 - Old Growth Forest (OGF)
 - Significant Woodland
 - Significant Wetland

- Notes**
- Coordinate System: NAD 1983 UTM Zone 18N
 - Base features produced under license with the Ontario Ministry of Natural Resources © Queen's Printer for Ontario, 2014.
 - Orthoimagery © First Base Solutions, 2014. Imagery taken in 2008.

November 2014
160960595

Client/Project
Windlectric Inc.
Amherst Island Wind Energy Project

Figure No.
5.2 **DRAFT**

Title
Significant Natural Features &
Wildlife Habitat



DRAFT

\\cd1220-02\01609\active\60960595\drawing\MXD\Terrestrial\NHA\Mod_Report\160960595_Fig5_SignificantWildlifeHabitat_20141111.mxd
Revised: 2014-11-12 By: pwnorsell

366000 367000 368000 369000 370000



Legend

- Study Area
- 120m Zone of Investigation
- Project Components
 - Turbine
 - Met Tower (Potential Location)
 - Access Road
 - Collector Line
 - Collector Line (New)
 - Collector Line (Removed)
 - Submarine Cable Path
 - Laydown Area and Crane Pad
 - Operation and Maintenance Building (Potential Location)
 - Turbine Blade Tip
 - Substation (Potential Location)
 - Potential Culvert Location
 - Point of Common Coupling
 - Mainland Cable Vault (Potential Location)
 - Island Cable Vault
 - Aboveground Storage Tanks (Potential Location)
 - Constructible Area
 - Mainland Dock (Potential Location)
 - Island Dock
 - Batch Plant (Potential Location)
 - Site Office (Potential Location)
 - Storage Shed
- Transmission Lines
 - Mainland Option 1
 - Mainland Option 2
 - Island Transmission Line
- Land Use
 - Central Staging Area
 - Switching Station (Potential Location)
- Existing Features
 - Road
 - Unopened Road Allowance
 - Railway
 - Hydro Line
 - Watercourse
 - Amherst Bay Life Science ANSI
 - Property Line
- Significant Wildlife Habitat Features
 - Snake Hibernacula (SN)
 - Amphibian Breeding (ABWO & ABWE)
 - Area-Sensitive Breeding Bird (ABB)
 - Marsh Breeding Bird (MBB)
 - Shrub/Early Successional Bird Breeding (SSB)
 - Turtle Overwintering (TO)
 - Shorebird Migratory Stopover (SM)
 - Landbird Migratory Stopover Area (ML)
 - Waterfowl Stopover & Staging - Terrestrial (WT)
 - Old Growth Forest (OGF)
 - Significant Woodland
 - Significant Wetland

Notes

- Coordinate System: NAD 1983 UTM Zone 18N
- Base features produced under license with the Ontario Ministry of Natural Resources © Queen's Printer for Ontario, 2014.
- Orthoimagery © First Base Solutions, 2014. Imagery taken in 2008.

November 2014
160960595

Client/Project

Windlectric Inc.
Amherst Island Wind Energy Project

Figure No.

5.3

DRAFT

Title

Significant Natural Features &
Wildlife Habitat

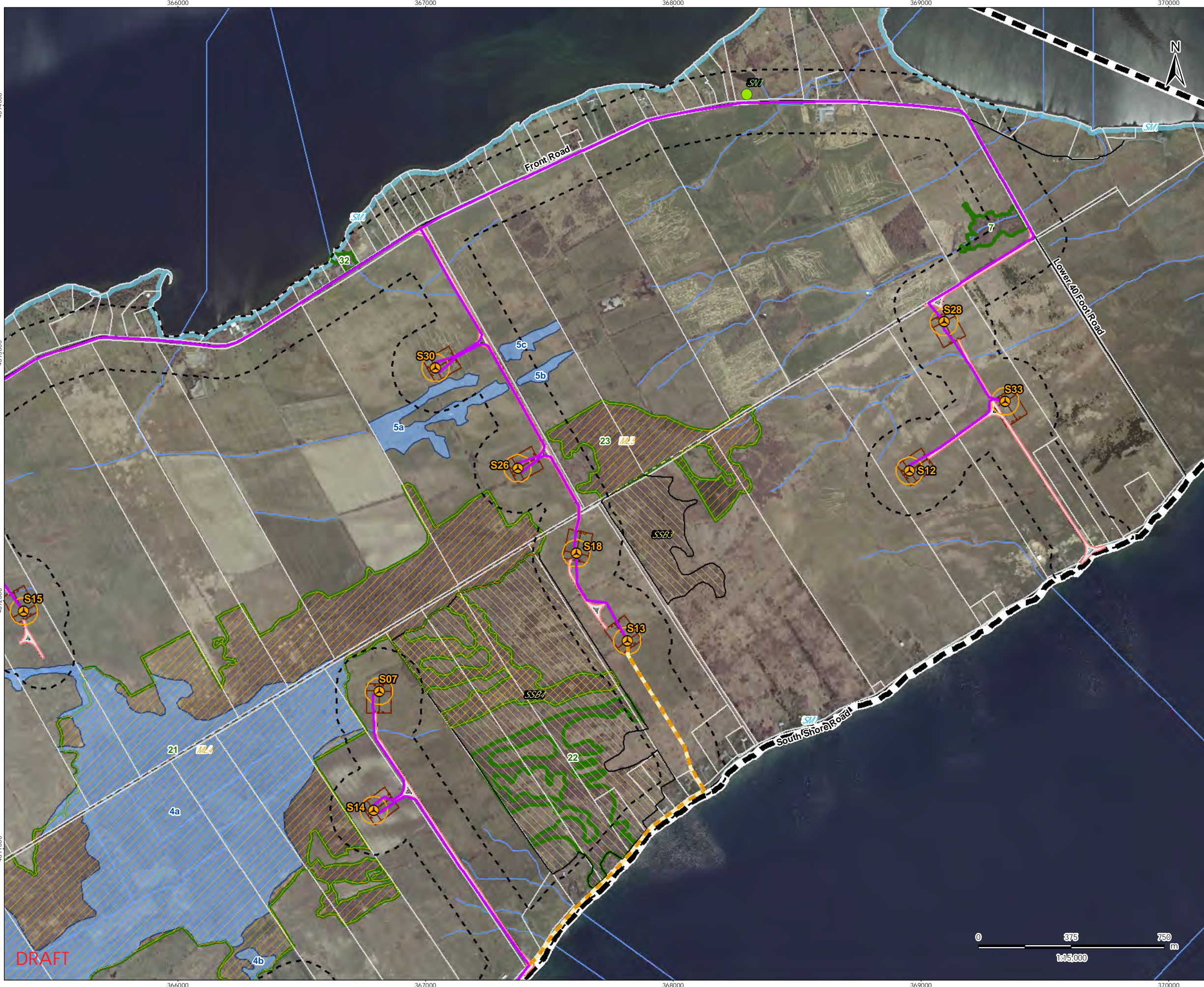

DRAFT



\\cd1220-02\01609\active\60960595\drawing\MXD\Terrestrial\NHA\Mod_Report\160960595_Fig5_SignificantWildlifeHabitat_20141111.mxd
Revised: 2014-11-12 By: pwnorsell

Legend

- Study Area
- 120m Zone of Investigation
- Project Components**
- Turbine
- Met Tower (Potential Location)
- Access Road
- Collector Line
- Collector Line (New)
- Collector Line (Removed)
- Submarine Cable Path
- Laydown Area and Crane Pad
- Operation and Maintenance Building (Potential Location)
- Turbine Blade Tip
- Substation (Potential Location)
- Potential Culvert Location
- Point of Common Coupling
- Mainland Cable Vault (Potential Location)
- Island Cable Vault
- Aboveground Storage Tanks (Potential Location)
- Constructible Area
- Mainland Dock (Potential Location)
- Island Dock
- Batch Plant (Potential Location)
- Site Office (Potential Location)
- Storage Shed
- Transmission Lines**
- Mainland Option 1
- Mainland Option 2
- Island Transmission Line
- Land Use**
- Central Staging Area
- Switching Station (Potential Location)
- Existing Features**
- Road
- Unopened Road Allowance
- Railway
- Hydro Line
- Watercourse
- Amherst Bay Life Science ANSI
- Property Line
- Significant Wildlife Habitat Features**
- Snake Hibernacula (SN)
- Amphibian Breeding (ABWO & ABWE)
- Area-Sensitive Breeding Bird (ABB)
- Marsh Breeding Bird (MBB)
- Shrub/Early Successional Bird Breeding (SSB)
- Turtle Overwintering (TO)
- Shorebird Migratory Stopover (SM)
- Landbird Migratory Stopover Area (ML)
- Waterfowl Stopover & Staging - Terrestrial (WT)
- Old Growth Forest (OGF)
- Significant Woodland
- Significant Wetland

Notes

1. Coordinate System: NAD 1983 UTM Zone 18N
2. Base features produced under license with the Ontario Ministry of Natural Resources © Queen's Printer for Ontario, 2014.
3. Orthoimagery © First Base Solutions, 2014. Imagery taken in 2008.

November 2014
160960595

Client/Project

Windlectric Inc.
Amherst Island Wind Energy Project

Figure No.

5.4

DRAFT

Title

Significant Natural Features &
Wildlife Habitat

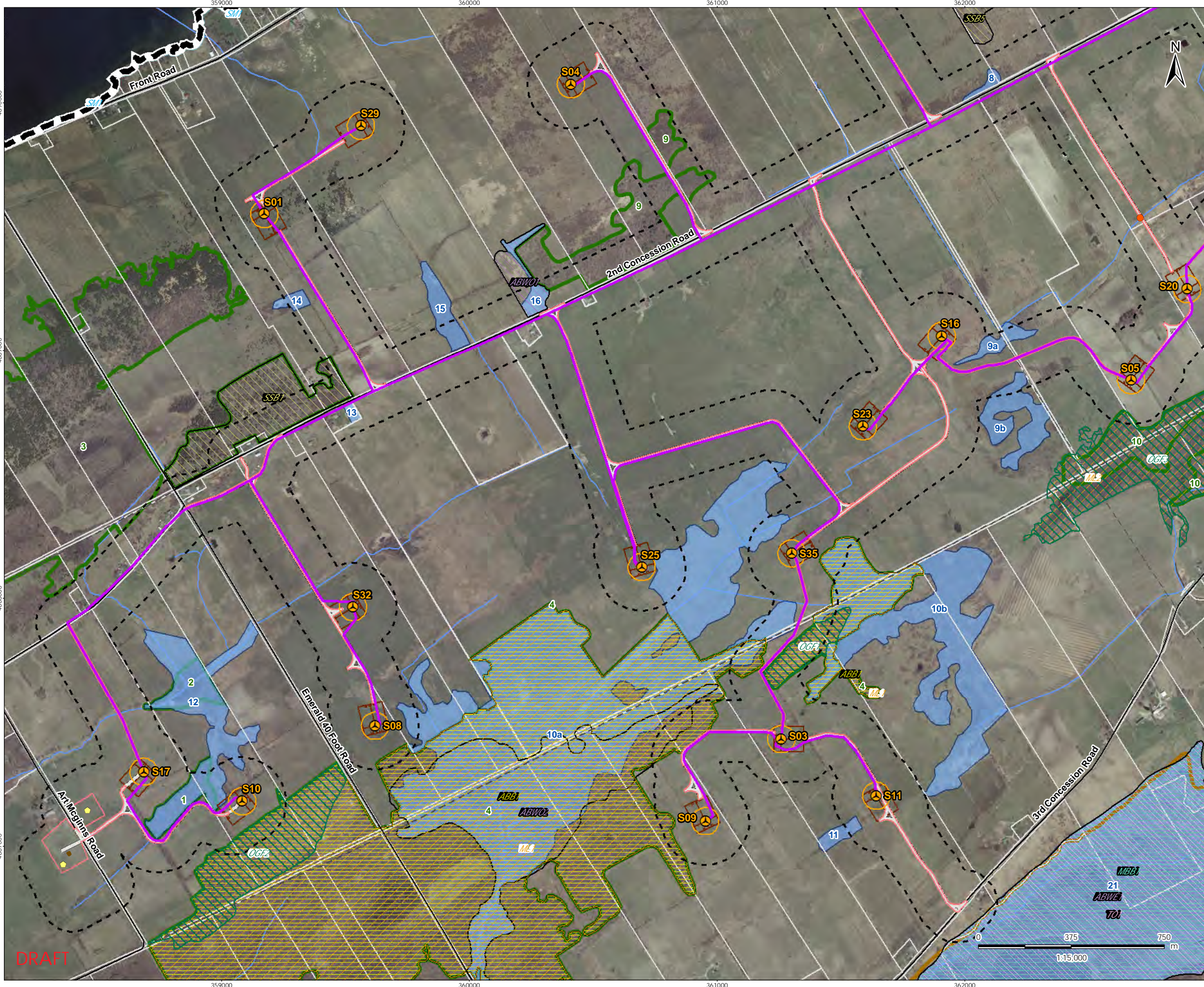

\\cd1220-102\01609\active\60960595\drawing\MXD\Terrestrial\NHA\Wood_Report\160960595_Fig5_SignificantWildlifeHabitat_20141111.mxd
 Revised: 2014-11-12 By: pwnorsell

DRAFT

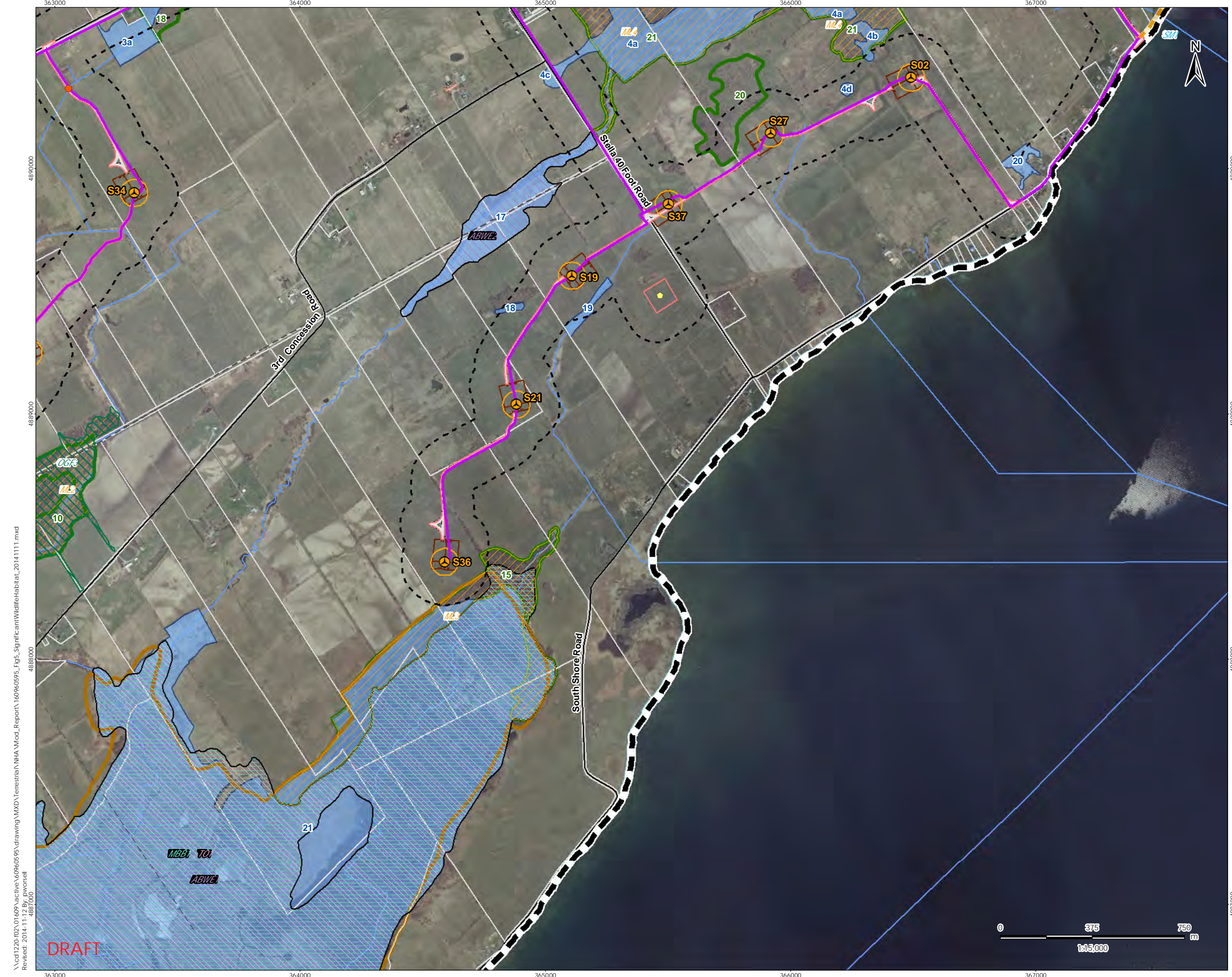

- Legend**
- Study Area
 - 120m Zone of Investigation
 - Project Components**
 - Turbine
 - Met Tower (Potential Location)
 - Access Road
 - Collector Line
 - Collector Line (New)
 - Collector Line (Removed)
 - Submarine Cable Path
 - Laydown Area and Crane Pad
 - Operation and Maintenance Building (Potential Location)
 - Turbine Blade Tip
 - Substation (Potential Location)
 - Potential Culvert Location
 - Point of Common Coupling
 - Mainland Cable Vault (Potential Location)
 - Island Cable Vault
 - Aboveground Storage Tanks (Potential Location)
 - Constructible Area
 - Mainland Dock (Potential Location)
 - Island Dock
 - Batch Plant (Potential Location)
 - Site Office (Potential Location)
 - Storage Shed
 - Transmission Lines**
 - Mainland Option 1
 - Mainland Option 2
 - Island Transmission Line
 - Land Use**
 - Central Staging Area
 - Switching Station (Potential Location)
 - Existing Features**
 - Road
 - Unopened Road Allowance
 - Railway
 - Hydro Line
 - Watercourse
 - Amherst Bay Life Science ANSI
 - Property Line
 - Significant Wildlife Habitat Features**
 - Snake Hibernacula (SN)
 - Amphibian Breeding (ABWO & ABWE)
 - Area-Sensitive Breeding Bird (ABB)
 - Marsh Breeding Bird (MBB)
 - Shrub/Early Successional Bird Breeding (SSB)
 - Turtle Overwintering (TO)
 - Shorebird Migratory Stopover (SM)
 - Landbird Migratory Stopover Area (ML)
 - Waterfowl Stopover & Staging - Terrestrial (WT)
 - Old Growth Forest (OGF)
 - Significant Woodland
 - Significant Wetland

Notes

- Coordinate System: NAD 1983 UTM Zone 18N
- Base features produced under license with the Ontario Ministry of Natural Resources © Queen's Printer for Ontario, 2014.
- Orthoimagery © First Base Solutions, 2014. Imagery taken in 2008.

November 2014
160960595

Client/Project
Windlectric Inc.
Amherst Island Wind Energy Project

Figure No.
5.5 **DRAFT**

Title
Significant Natural Features &
Wildlife Habitat



\\cd1220-102\01609\active\60960595\drawing\MXD\Terrestrial\NHA\Mod_Report\160960595_Fig5_SignificantWildlifeHabitat_20141111.mxd
 Revised: 2014-11-12 By: pwnorsell
 4887000

DRAFT

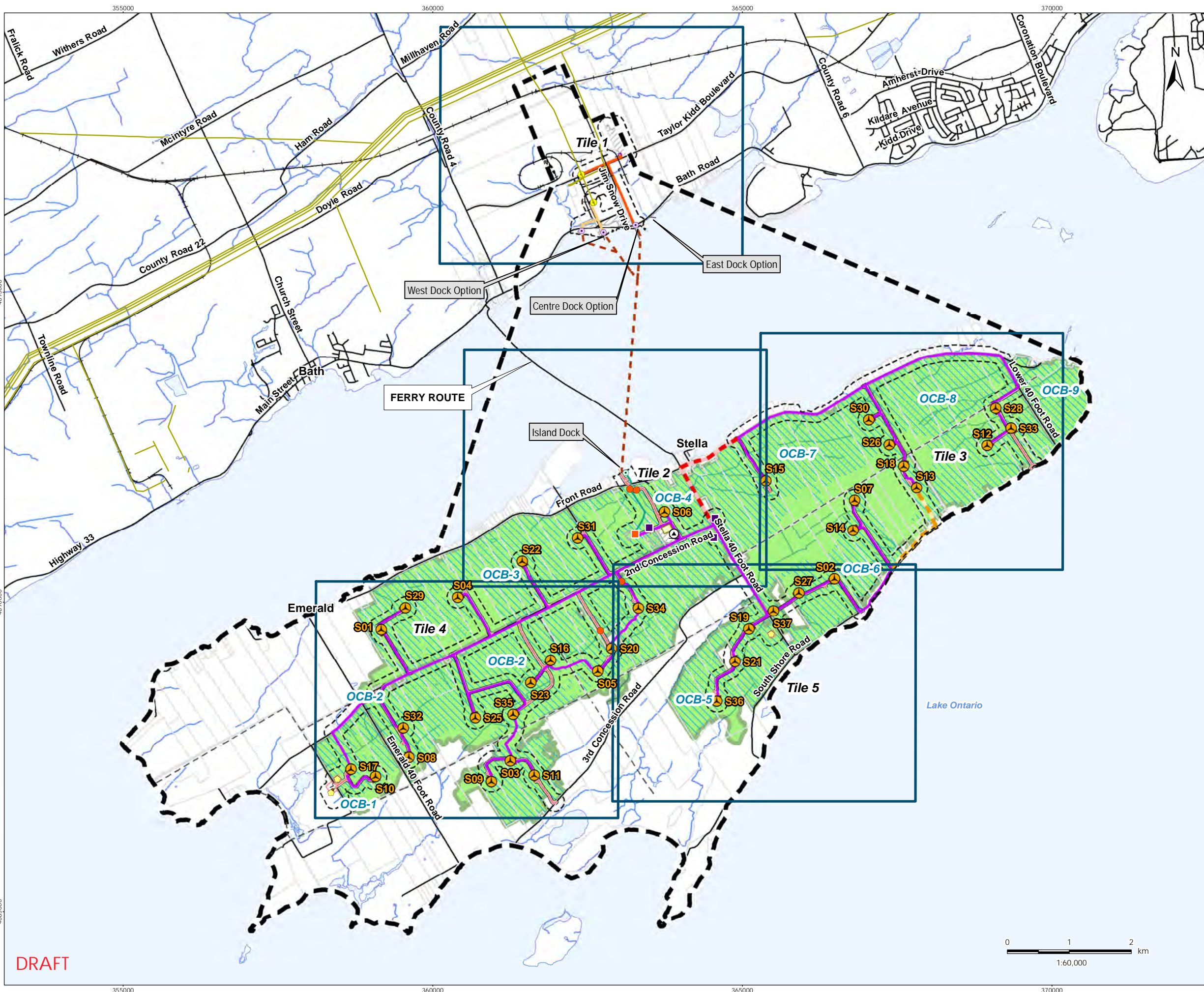

- Legend**
- Study Area
 - 120m Zone of Investigation
 - Project Components**
 - Turbine
 - Met Tower (Potential Location)
 - Substation (Potential Location)
 - Access Road
 - Collector Line
 - Collector Line (New)
 - Collector Line (Removed)
 - Submarine Cable Path
 - Laydown Area and Crane Pad
 - Operation and Maintenance Building (Potential Location)
 - Potential Culvert Location
 - Point of Common Coupling
 - Mainland Cable Vault (Potential Location)
 - Island Cable Vault
 - Aboveground Storage Tanks (Potential Location)
 - Constructible Area
 - Mainland Dock (Potential Location)
 - Island Dock
 - Batch Plant (Potential Location)
 - Site Office (Potential Location)
 - Storage Shed
 - Transmission Lines**
 - Mainland Option 1
 - Mainland Option 2
 - Island Transmission Line
 - Land Use**
 - Central Staging Area
 - Switching Station (Potential Location)
 - Existing Features**
 - Road
 - Unopened Road Allowance
 - Railway
 - Hydro Line
 - Watercourse
 - Waterbody
 - Property Line
 - Open Country Breeding Bird Area (OCB) (OCB habitats are transparent with hatching)
 - Raptor Wintering Area (RWA)

Notes

- Coordinate System: NAD 1983 UTM Zone 18N
- Base features produced under license with the Ontario Ministry of Natural Resources © Queen's Printer for Ontario, 2014.

November 2014
160960595

Client/Project
Windlectric Inc.
Amherst Island Wind Energy Project

Figure No.
6.0

DRAFT

Title
Significant Open Country Breeding Bird & Raptor Wintering Areas - Overview

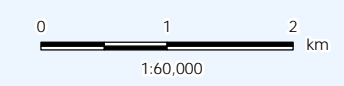

DRAFT

\\cd1220-102\01609\active\60960595\drawing\MXD\Terrestrial\NHA\Mod_Report\160960595_Fig6_SignificantRWA_OCB_Overview_20141111.mxd
 Revised: 2014-11-12 By: p.worsell
 4885000



- Legend**
- Study Area
 - 120m Zone of Investigation
 - Project Components**
 - Turbine
 - Met Tower (Potential Location)
 - Access Road
 - Collector Line
 - Collector Line (New)
 - Collector Line (Removed)
 - Submarine Cable Path
 - Laydown Area and Crane Pad
 - Operation and Maintenance Building (Potential Location)
 - Turbine Blade Tip
 - Substation (Potential Location)
 - Potential Culvert Location
 - Point of Common Coupling
 - Mainland Cable Vault (Potential Location)
 - Island Cable Vault
 - Aboveground Storage Tanks (Potential Location)
 - Constructible Area
 - Mainland Dock (Potential Location)
 - Island Dock
 - Batch Plant (Potential Location)
 - Site Office (Potential Location)
 - Storage Shed
 - Transmission Lines**
 - Mainland Option 1
 - Mainland Option 2
 - Island Transmission Line
 - Land Use**
 - Central Staging Area
 - Switching Station (Potential Location)
 - Existing Features**
 - Road
 - Unopened Road Allowance
 - Railway
 - Hydro Line
 - Watercourse
 - Property Line
 - Open Country Breeding Bird Area (OCB)
(OCB habitats are transparent with hatching)
 - Raptor Wintering Area (RWA)

Notes

- Coordinate System: NAD 1983 UTM Zone 18N
- Base features produced under license with the Ontario Ministry of Natural Resources © Queen's Printer for Ontario, 2014.
- Orthoimagery © First Base Solutions, 2014. Imagery taken in 2008.

November 2014
160960595

Client/Project
Windlectric Inc.
Amherst Island Wind Energy Project

Figure No.
6.1 **DRAFT**

Title
Significant Open Country Breeding Bird & Raptor Wintering Areas



\\cd1220-102\01609\active\60960595\drawing\MXD\Terrestrial\NHA\Mod_Report\160960595_Fig6_SignificantRWA_OCB_20141111.mxd
 Revised: 2014-11-12 By: pworsell

DRAFT

361000 362000 363000 364000 365000

4894000
4893000
4892000
4891000



- Legend**
- Study Area
 - 120m Zone of Investigation
 - Project Components**
 - Turbine
 - Met Tower (Potential Location)
 - Access Road
 - Collector Line
 - Collector Line (New)
 - Collector Line (Removed)
 - Submarine Cable Path
 - Laydown Area and Crane Pad
 - Operation and Maintenance Building (Potential Location)
 - Turbine Blade Tip
 - Substation (Potential Location)
 - Potential Culvert Location
 - Point of Common Coupling
 - Mainland Cable Vault (Potential Location)
 - Island Cable Vault
 - Aboveground Storage Tanks (Potential Location)
 - Constructible Area
 - Mainland Dock (Potential Location)
 - Island Dock
 - Batch Plant (Potential Location)
 - Site Office (Potential Location)
 - Storage Shed
 - Transmission Lines**
 - Mainland Option 1
 - Mainland Option 2
 - Island Transmission Line
 - Land Use**
 - Central Staging Area
 - Switching Station (Potential Location)
 - Existing Features**
 - Road
 - Unopened Road Allowance
 - Railway
 - Hydro Line
 - Watercourse
 - Property Line
 - Open Country Breeding Bird Area (OCB) (OCB habitats are transparent with hatching)
 - Raptor Wintering Area (RWA)



- Notes**
1. Coordinate System: NAD 1983 UTM Zone 18N
 2. Base features produced under license with the Ontario Ministry of Natural Resources © Queen's Printer for Ontario, 2014.
 3. Orthoimagery © First Base Solutions, 2014. Imagery taken in 2008.

November 2014
160960595

Client/Project
Windlectric Inc.
Amherst Island Wind Energy Project

Figure No.
6.2 **DRAFT**

Title
Significant Open Country Breeding Bird & Raptor Wintering Areas

DRAFT
OCB-3

361000 362000 363000 364000 365000

\\cd1220-02\01609\active\60960595\drawing\MXD\Terrestrial\NHA\Mod_Report\160960595_Fig6_SignificantRWA_OCB_20141111.mxd
Revised: 2014-11-12 By: pwnorsell



- Legend**
- Study Area
 - 120m Zone of Investigation
 - Project Components**
 - Turbine
 - Met Tower (Potential Location)
 - Access Road
 - Collector Line
 - Collector Line (New)
 - Collector Line (Removed)
 - Submarine Cable Path
 - Laydown Area and Crane Pad
 - Operation and Maintenance Building (Potential Location)
 - Turbine Blade Tip
 - Substation (Potential Location)
 - Potential Culvert Location
 - Point of Common Coupling
 - Mainland Cable Vault (Potential Location)
 - Island Cable Vault
 - Aboveground Storage Tanks (Potential Location)
 - Constructible Area
 - Mainland Dock (Potential Location)
 - Island Dock
 - Batch Plant (Potential Location)
 - Site Office (Potential Location)
 - Storage Shed
 - Transmission Lines**
 - Mainland Option 1
 - Mainland Option 2
 - Island Transmission Line
 - Land Use**
 - Central Staging Area
 - Switching Station (Potential Location)
 - Existing Features**
 - Road
 - Unopened Road Allowance
 - Railway
 - Hydro Line
 - Watercourse
 - Property Line
 - Open Country Breeding Bird Area (OCB) (OCB habitats are transparent with hatching)
 - Raptor Wintering Area (RWA)

Notes

- Coordinate System: NAD 1983 UTM Zone 18N
- Base features produced under license with the Ontario Ministry of Natural Resources © Queen's Printer for Ontario, 2014.
- Orthoimagery © First Base Solutions, 2014. Imagery taken in 2008.

November 2014
160960595

Client/Project
Windlectric Inc.
Amherst Island Wind Energy Project

Figure No.
6.3 DRAFT

Title
Significant Open Country Breeding Bird & Raptor Wintering Areas

\\cd1220-02\01609\active\60960595\drawing\MXD\Terrestrial\NHA\Mod_Report\160960595_Fig6_SignificantRWA_OCB_20141111.mxd
 Revised: 2014-11-12 By: pworsell

DRAFT



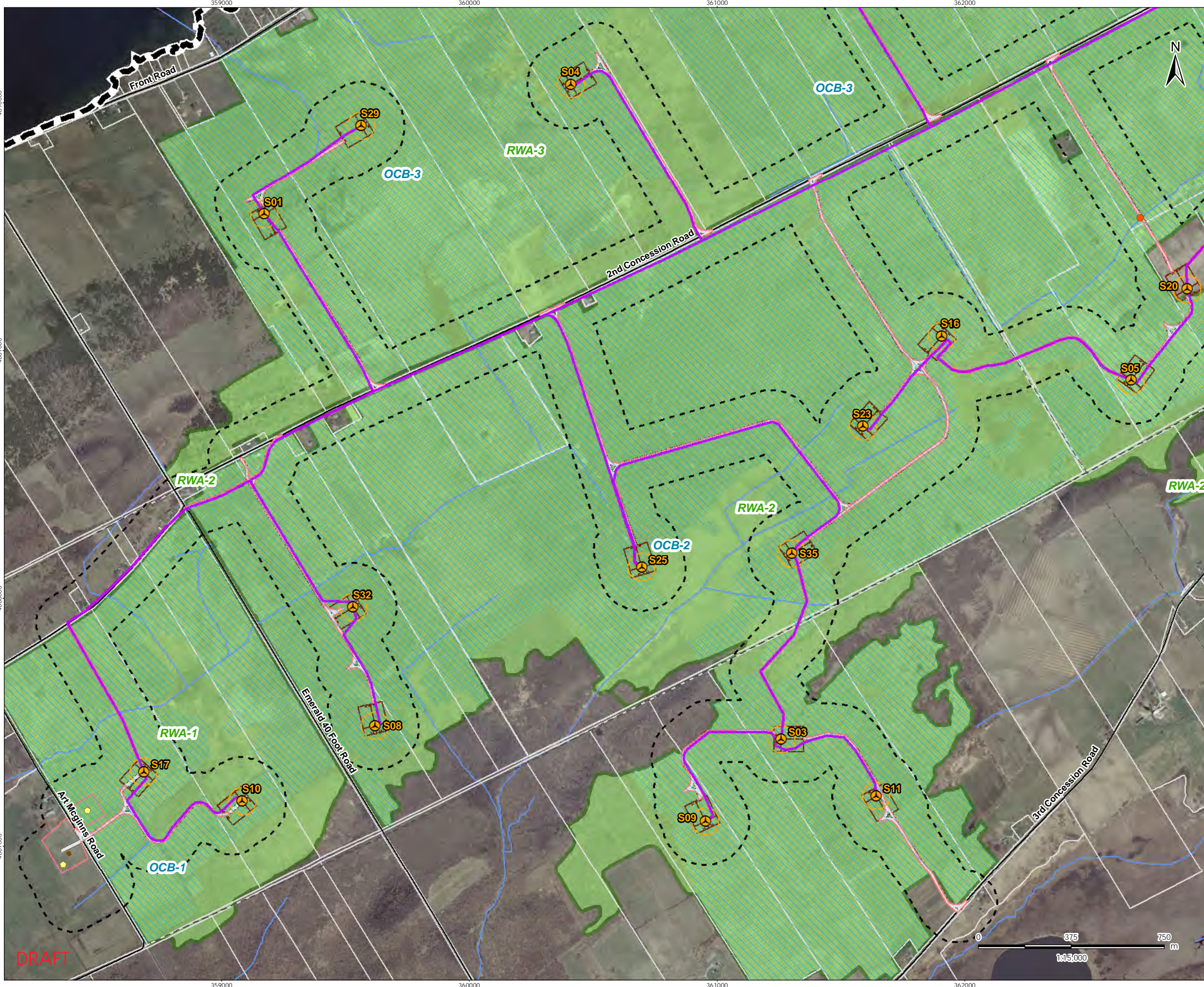

- Legend**
- Study Area
 - 120m Zone of Investigation
 - Project Components**
 - Turbine
 - Met Tower (Potential Location)
 - Access Road
 - Collector Line
 - Collector Line (New)
 - Collector Line (Removed)
 - Submarine Cable Path
 - Laydown Area and Crane Pad
 - Operation and Maintenance Building (Potential Location)
 - Turbine Blade Tip
 - Substation (Potential Location)
 - Potential Culvert Location
 - Point of Common Coupling
 - Mainland Cable Vault (Potential Location)
 - Island Cable Vault
 - Aboveground Storage Tanks (Potential Location)
 - Constructible Area
 - Mainland Dock (Potential Location)
 - Island Dock
 - Batch Plant (Potential Location)
 - Site Office (Potential Location)
 - Storage Shed
 - Transmission Lines**
 - Mainland Option 1
 - Mainland Option 2
 - Island Transmission Line
 - Land Use**
 - Central Staging Area
 - Switching Station (Potential Location)
 - Existing Features**
 - Road
 - Unopened Road Allowance
 - Railway
 - Hydro Line
 - Watercourse
 - Property Line
 - Open Country Breeding Bird Area (OCB) (OCB habitats are transparent with hatching)
 - Raptor Wintering Area (RWA)

Notes

- Coordinate System: NAD 1983 UTM Zone 18N
- Base features produced under license with the Ontario Ministry of Natural Resources © Queen's Printer for Ontario, 2014.
- Orthoimagery © First Base Solutions, 2014. Imagery taken in 2008.

November 2014
160960595

Client/Project
Windlectric Inc.
Amherst Island Wind Energy Project

Figure No.
6.4 **DRAFT**

Title
Significant Open Country Breeding Bird & Raptor Wintering Areas

\\cd1220-102\01609\active\160960595\drawing\MXD\Terrestrial\NHA\Mod_Report\160960595_Fig6_SignificantRWA_OCB_20141111.mxd
 Revised: 2014-11-12 By: pwnorsell

DRAFT

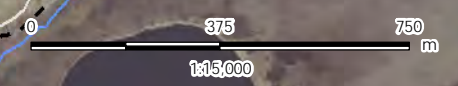



- Legend**
- Study Area
 - 120m Zone of Investigation
 - Project Components**
 - Turbine
 - Met Tower (Potential Location)
 - Access Road
 - Collector Line
 - Collector Line (New)
 - Collector Line (Removed)
 - Submarine Cable Path
 - Laydown Area and Crane Pad
 - Operation and Maintenance Building (Potential Location)
 - Turbine Blade Tip
 - Substation (Potential Location)
 - Potential Culvert Location
 - Point of Common Coupling
 - Mainland Cable Vault (Potential Location)
 - Island Cable Vault
 - Aboveground Storage Tanks (Potential Location)
 - Constructible Area
 - Mainland Dock (Potential Location)
 - Island Dock
 - Batch Plant (Potential Location)
 - Site Office (Potential Location)
 - Storage Shed
 - Transmission Lines**
 - Mainland Option1
 - Mainland Option 2
 - Island Transmission Line
 - Land Use**
 - Central Staging Area
 - Switching Station (Potential Location)
 - Existing Features**
 - Road
 - Unopened Road Allowance
 - Railway
 - Hydro Line
 - Watercourse
 - Property Line
 - Open Country Breeding Bird Area (OCB) (OCB habitats are transparent with hatching)
 - Raptor Wintering Area (RWA)

Notes

- Coordinate System: NAD 1983 UTM Zone 18N
- Base features produced under license with the Ontario Ministry of Natural Resources © Queen's Printer for Ontario, 2014.
- Orthoimagery © First Base Solutions, 2014. Imagery taken in 2008.

November 2014
160960595

Client/Project
Windlectric Inc.
Amherst Island Wind Energy Project

Figure No.
6.5 DRAFT

Title
Significant Open Country Breeding Bird & Raptor Wintering Areas



\\cd1220-102\01609\active\60960595\drawing\MXD\Terrestrial\NHA\Mod_Report\160960595_Fig6_SignificantRWA_OCB_20141111.mxd
 Revised: 2014-11-12 By: pwnorsell
 4887000

DRAFT

Attachment 2

Updates to NHA Tables

Update to Table 7B: Site Investigation Results - Woodlands

Woodland #	Feature Size (ha)	Figure #	Composition	Description	Attributes	Functions	Significance
22	15.03	3	FOD7-2 (Fresh-Moist Ash Lowland Deciduous forest)	<p>Woodland feature 22 is found north of South Shore Rd and is separated from woodland feature 21 by a band of cultural meadow of approximately 100 m, forming a distinct woodland feature.</p> <p>Numerous areas of cultural meadow are found through this feature and are not included in the total area.</p> <p>Land use immediately surrounding the woodland feature is primarily managed agricultural lands, cultural meadow, and to the north woodland feature 21.</p>	<p>Snags were considered rare to occasional with abundant small snags <10 cm dbh.</p> <p>Age structure young to mid age (most trees <10 to 24 cm dbh); with some, rarely, >25 cm dbh</p> <p>No trees were observed that were >25 dbh and contained cavities.</p> <p>Overall canopy cover was primarily <60 %; characterized as open canopy.</p> <p>No specialized wildlife habitat features (hibernacula, stick nests, etc.) observed.</p> <p>Vernal pools absent.</p> <p>No disturbance noted.</p>	<ul style="list-style-type: none"> • Large woodland • Provides connectivity between significant natural features 	Unknown, requires Evaluation of Significance

Update to Table 3.9: Natural Features Carried Forward to Evaluation of Significance

Feature ID	Feature Type	Distance to Project Infrastructure Within 120 m (m)	Identified in Records Review	Evaluation of Significance Required
Woodlands				
21	Woodland	WT-44 UL-3 AR-39 TC-40	No	Yes
22	Woodland	UL - 82	No	Yes
Seasonal Concentration Areas				
RWA-6	Raptor Wintering Area	WT – overlapping AR – overlapping UL – overlapping TC – overlapping BU – overlapping	No	Yes
SM1	Shorebird Migratory Stopover Area	UL – overlapping AR – overlapping	No	Yes
Habitat for Species of Conservation Concern				
OCB-6	Open Country Bird Breeding Habitat	WT – overlapping AR – overlapping UL – overlapping TC – overlapping BU – overlapping	No	Yes
SSB4	Shrub/Early Successional Bird Breeding Habitat	WT – 65 UL – 1 AR – 66 TC - 65	No	Yes
Legend: WT: Wind Turbine; UL: Underground Transmission Line; AR: Access Road, OL: Overhead Transmission Line, TC: Temporary Construction Areas, BU: Building/Substation				

Update to Table 10B: Evaluation of Significance – Woodlands

Woodland #	Size (>4 ha)	Woodland Interior	Proximity to Other Significant Woodlands or Habitats	Linkages	Water Protection	Woodland Diversity Representation	Uncommon Characteristics	Significant Woodland
	Y/N	Y/N	Y/N	Y/N	Y/N	Y/N	Y/N	Y/N
22	Yes	No	No	Yes	No	No	No	Yes

Update to Table 4.8: Summary of Evaluation of Significance of Natural Features

Feature ID	Feature Type	Distance to Project Infrastructure Within 120 m (m)	Located in or within 120 m of Project Location	Significant? (Y/N)	Carried Forward to EIS (Y/N)
Woodlands					
21	Woodland	WT-44 UL-3 AR-39 TC-40	Within 120 m	Yes	Yes
22	Woodland	UL-82	Within 120 m	Yes	Yes
Seasonal Concentration Areas					
RWA-6	Raptor Wintering Area	WT – overlapping AR – overlapping UL – overlapping TC – overlapping BU – overlapping	In	Yes	Yes
SM1	Shorebird Migratory Stopover Area	UL – overlapping AR – overlapping	Within 120 m	Yes	Yes
Habitat for Species of Conservation Concern					
OCB-6	Open Country Bird Breeding Habitat	WT – overlapping AR – overlapping UL – overlapping TC – overlapping BU – overlapping	In	Yes	Yes
SSB-4	Shrub/Early Successional Bird Breeding Habitat	WT – 65 UL – 1 AR – 66 TC - 65	Within 120 m	Yes	Yes
Legend: WT: Wind Turbine; UL: Underground Transmission Line; AR: Access Road, OL: Overhead Transmission Line, TC: Temporary Construction Areas, BU: Building/Substation					

Attachment 3

Sections of NHA/EIS

****note to reviewer: the following text has been copied from previously approved NHA/EIS**

2.0 RECORDS REVIEW

2.1 Methods

This Records Review report was prepared in accordance with O. Reg. 359/09, s. 25 (3).

Background data were collected and reviewed to identify natural features located in, or within, 120 metres of the Project Location (i.e., the Zone of Investigation). Documents reviewed and agencies contacted as part of the Records Review included but were not limited to:

- Ontario Ministry of Natural Resources (MNR). Natural heritage data request and proposed Site Investigation work program submitted May 12, 2011. MNR provided a written response on natural heritage features and Provincially Significant Wetlands (PSW) for the Project Study Area on May 30, 2011 (including Provincially Significant Wetland Evaluations for Wemps Bay Marsh, Nut Island Duck Club Marsh and Long Point Marsh) and during a teleconference on June 3, 2011. Stantec has been in correspondence with the Renewable Energy Planning Ecologist for this region on an on-going basis;
- Natural Heritage Information Centre (NHIC 2010) database. February 2012. Natural Areas and Species records search. Biodiversity explorer, <http://nhic.mnr.gov.on.ca>. OMNR, Peterborough. Accessed February 2012;
- Land Information Ontario (LIO). 2012. LIO digital mapping of natural heritage features;
- Renewable Energy Atlas: bat hibernacula mapping (LIO 2012);
- Ontario Parks Planning and Management Information (<http://www.ontarioparks.com/english/plan-res.html>).
- Historic air photos of Amherst Island (Northway-Photomap Remote Sensing Ltd 1948)

Conservation Authority

- Cataraqui Region Conservation Authority/Loyalist Township. Letter sent to Planner/Chief Building Official of Loyalist Township and copied to General Manager of CRCA on September 16, 2008. Response and screening maps received from Development Officer of CRCA September 26, 2008;
- Letter from Cataraqui Region Conservation Authority (CRCA) to Windlectric Inc. dated March 28, 2011;
- Background information request sent to the General Manager at CRCA on August 17, 2011;
- Windlectric and Stantec met with CRCA representatives on October 6, 2011;
- Cataraqui Region Conservation Authority mapping (2011);
- Cataraqui Region Conservation Authority. Natural Heritage Study Final Report. August 2006.
- Owl Woods Management Strategy (Ecological Services 2011)

Local Municipal Government

- Letter sent to Planner/Chief Building Official of Loyalist Township;
- Windlectric and Stantec met with Loyalist Township representatives on October 6, 2011;
- Loyalist Township Official Plan (2010) and associated Schedules A and B.

Other data sources

- Important Bird Areas (IBA) database (Bird Studies Canada and BirdLife International, undated);
- Ontbirds Archives;
- eBird Canada Checklist;
- Various wildlife atlases (birds, mammals, amphibians and reptiles);
- Kingston Field Naturalists (KFN). Meeting and site walk with Kurt Hennige and Erwin Batalla on May 20, 2011, to visit KFN property and discuss on-island bird communities. Request for bird nesting data sent to Kurt Hennige on June 2, 2011. Bird nesting data received June 24, 2011;
- Geographic and Habitat Fidelity in the Short-eared Owl (*Asio flammeus*) (Keyes 2011); including specific information regarding Short-eared Owls breeding on Amherst Island;
- Amherst Island Beacon Archives;
- Discussion with local bird expert Janet Scott regarding owl populations on Amherst Island;
- Golder and Associates. Report on Fall Migration Bird Monitoring on Amherst Island, Ontario. October 2008. Addendum to Fall Migration Bird Monitoring on Amherst Island, Ontario. December 2008.

3.0 SITE INVESTIGATION

3.1 Methods

The site investigations undertaken detailed the current conditions in and within 120 m of the Project Location, and were based on the information about the Project Location and siting that was current at the time of the respective survey. All surveys conducted within the Study Area were completed by qualified personnel. Land access was available for all land parcels where Project components are proposed, and areas within 120 m of the Project Location were traversed on foot during site investigations where land access was available.

All site investigations were carried out in accordance with O. Reg. 359/09 and the NHA Guide for Renewable Energy Projects (MNR 2011a), using guidance provided in the SWHTG and the Draft SWH Ecoregion 6E Criterion Schedule (MNR 2012).

3.1.1 Alternative Site Investigation Methods

Alternative site investigations consisted of assessments conducted from roadsides and property boundaries in locations within 120 m of the Project Location where access was not required. This occurred in locations where underground transmission lines are proposed within the road right-of-way and the adjacent property is active agriculture or residential property. Alternative site investigations, comprised of visual scans from roadsides and/or property boundaries in combination with air photos, were undertaken in these locations.

3.1.2 Vegetation Community and Vascular Plants Assessment

Ecological Land Classification (ELC) and preliminary botanical inventories of the vegetation communities in and within 120 m of the Project Location were conducted by Stantec on July 26-29, August 2-5, August 17-19, November 11, 2011 and March 27-28, May 18, and August 15, 2012.

Vegetation communities were delineated on aerial photographs and checked in the field. Vascular plant species lists were recorded separately for each community. Community characterizations were then based on the ELC system (Lee et al., 1998). English colloquial names and scientific binomials of plant species generally follow Newmaster et al. (1998). Specific emphasis was placed on searching for plant species of conservation concern identified through the records review with historical occurrences within the study area.

Plant species were considered rare if designated provincially as S1 (critically imperiled), S2 (imperiled) or S3 (vulnerable). Species having a high coefficient of conservatism (9 or 10) as designated by Oldham et al. (1995) were also considered species of note.

3.1.3 Wetland Confirmation and Delineation

Wetlands are defined in the REA regulation as features that are swamp, marsh, bog, or fen that are seasonally or permanently covered by shallow water or has the water table close to the surface, and have hydric soils and vegetation dominated by hydrophytic or water-tolerant plants (OMNR 2011a). Wetlands are identified during ELC surveys and are further evaluated using the Ontario Wetland Evaluation System (OWES).

Previously unidentified wetlands within 120 m of the Project Location identified during the course of the site investigations were delineated during the vegetation community assessment and vascular plant surveys described in **Section 3.1.2**. The wetland boundaries were mapped through reconciling aerial photographs and observations made during the site investigations in accordance with the methods outlined in the OWES Southern Manual (MNR 2002).

3.1.4 Woodlands

Woodlands include treed areas, woodlots, or forested areas, other than cultivated fruit or nut orchards or plantations established for the purpose of producing Christmas trees (OMNR 2011a).

The limits of all woodlands that occur, or partially occur, in or within 120 m of the Project Location were delineated through aerial photo interpretation and confirmed during site investigations.

Woodlands were delineated using the driplines of the trees. Information regarding woodland size, ecological function and uncommon characteristics was collected during ELC surveys and through GIS analysis. Historical air photos were used to determine the age and history of woodlands (Northway-Photomap Remote Sensing Ltd. 1948). Treed areas identified during vegetation surveys were compared to the definition of woodlands provided in O.Reg. 359/09 to delineate the limits of woodlands.

3.1.5 Valleylands

Valleylands are natural areas south and east of the Canadian Shield that have flowing or standing water for some period of the year. They are linear systems stretching across the landscape from headwater areas into other aquatic features such as lakes and wetlands. The boundaries of valleylands are defined based on their geomorphology, either by the stable top-of-bank, the flooding hazard limit, or limits of riparian vegetation. Conservation Authorities can provide regulated mapping and ELC surveys can provide further detail on these natural features. (OMNR 2011a)

Areas in and within 120 m of the Project Location were searched for the presence of characteristics of valleylands as defined within O. Reg. 359/09.

3.1.6 Areas of Natural and Scientific Interest (ANSI)

The Amherst Bay Life Science ANSI is located within 120 m of the Project Location and was identified in the Records Review.

3.1.7 Wildlife and Wildlife Habitat

Site investigations focused on determining whether candidate significant wildlife habitats, as identified during the Records Review, have the potential to occur in or within 120 m of the Project Location. Criteria used to identify candidate significant wildlife habitat were derived from the Significant Wildlife Habitat Technical Guide (MNR 2000) and the Draft SWH Ecoregion 6E Criterion Schedule. Specific emphasis was placed on determining whether the critical habitat features required to support significant wildlife habitat were present in natural features in or within 120 m of the Project Location. Methods for identifying candidate significant wildlife habitats are shown in **Tables 3.1** and **Table 3.3**.

Table 3.1: Characteristics Used to Identify Candidate Seasonal Concentration Areas

Candidate Seasonal Concentration Area	Criteria	Methods
Shorebird Migratory Stopover Area	<ul style="list-style-type: none"> • Shorelines of lakes, rivers and wetlands, including beach areas, bars and seasonally flooded, muddy and un-vegetated shoreline habitats. • Great Lakes coastal shorelines, including groynes and other forms of amour rock lakeshores, are extremely important for migratory shorebirds in May to mid-June and early July to October. • Sewage treatment ponds and storm water ponds do 	<ul style="list-style-type: none"> • The shoreline of Lake Ontario, apart from residential areas, was considered candidate habitat. • The presence of shorebird migratory stopover areas within suitable ELC communities was assessed.

Table 3.1: Characteristics Used to Identify Candidate Seasonal Concentration Areas

Candidate Seasonal Concentration Area	Criteria	Methods
	<ul style="list-style-type: none"> not qualify as a significant wildlife habitat. The following community types: Meadow Marsh (MAM), Beach/Bar (BB), or Sand Dune (SD) 	
Raptor Wintering Area	<ul style="list-style-type: none"> Presence of fields and woodlands. i.e. at least one of the following Community Types: Deciduous Forest (FOD), Mixed Forest (FOM) or Coniferous Forest (FOC), in addition to one of the following Upland Community Types: Meadow (CUM), Thicket (CUT), Savannah (CUS), Woodland (CUW) (<60% cover) that are >20 ha and provide roosting, foraging and resting habitats for wintering raptors. The habitat provides a combination of fields and woodlands that provide roosting, foraging and resting habitats for wintering raptors. Raptor wintering sites need to be > 20 ha with a combination of forest and upland, Least disturbed sites, idle/fallow or lightly grazed field/meadow (>15 ha) with adjacent woodlands. Upland habitat (CUM, CUT, CUS, CUW), must represent at least 15 ha of the 20 ha minimum size. 	<ul style="list-style-type: none"> Vegetation community classifications and size calculations were utilized to assess features within 120 m of the Project Location that would support raptor wintering areas.

Table 3.2: Characteristics Used to Identify Candidate Habitat for Species of Conservation Concern

Candidate Habitat for Species of Conservation Concern	Criteria	Methods
Open Country Bird Breeding Habitat	<ul style="list-style-type: none"> Grassland areas > 30 ha, not Class 1 or Class 2 agricultural lands, with no row-cropping or intensive hay or livestock pasturing in the last 5 years, in the following Community Type: Meadow (CUM). Condition of existing habitat at site (level of disturbance) is an important consideration. For example, fields with intensive agriculture are not considered candidate habitat. Fields with light grazing are considered candidate habitat) Size and location of habitat Potential for long-term protection of the habitat Representation of species/habitat within the municipality. 	<ul style="list-style-type: none"> Site investigations were conducted to assess the potential for grassland communities in and within 120 m of the Project Location to support area-sensitive bird species, through the delineation and verification of grassland communities by ELC. Swallow migratory staging was also included in this type of habitat for Amherst Island because these species use this habitat for foraging during fall migration. More information is provided in Section 4.2.3. The farming practice of hay field cutting before the end of the breeding cycle for grassland birds can reduce breeding success for these species up to 94% and hayfields are not considered to support viable populations of grassland breeding bird species (COSSARO 2010); however, due to the importance of Amherst Island for bird migration and grassland species such as the Short-eared Owl, all hayfields, pastures, and cultural meadows have been identified as candidate significant wildlife

Table 3.2: Characteristics Used to Identify Candidate Habitat for Species of Conservation Concern

Candidate Habitat for Species of Conservation Concern	Criteria	Methods
Shrub/Early Successional Bird Breeding Habitat	<ul style="list-style-type: none"> • Oldfield areas succeeding to shrub and thicket habitats >10 ha, not Class 1 or Class 2 agricultural lands, with no row-cropping or intensive hay or livestock pasturing in the last 5 years, in the following Community Types: Thickets (CUT), Savannahs (CUS), or Woodlands (CUW). • Condition of existing habitat at site. • Size and location of habitat. • Potential for long-term protection of the habitat – should have a history of longevity, either abandoned fields or pasturelands. • Representation of species/habitat within the municipality. 	<p>habitat.</p> <ul style="list-style-type: none"> • Site investigations were conducted to assess the potential for this habitat type using ELC to delineate thicket and savannah type communities.

4.0 EVALUATION OF SIGNIFICANCE

4.1 METHODS

Wetlands and Life Science ANSIs were determined to be provincially significant if they had been identified as such by MNR. This information was obtained from NHIC and through correspondence with the local MNR District. Non-provincially significant wetlands are those that have been evaluated but did not receive sufficient points to be considered provincially significant. Wetlands that have yet to be examined are termed unevaluated. These unevaluated wetlands and those additional wetlands identified during field investigations were assessed during site investigations and desktop analyses using evaluation criteria or procedures established and accepted by MNR.

Valleylands, wildlife habitat and woodlands were considered to be significant if MNR has identified them as such or when evaluated as significant using procedures established by MNR.

Sources used in the Evaluation of Significance for the natural features within 120 m of the Project Location included:

- Ontario Wetland Evaluation System (MNR 2002);
- NHA Guide for Renewable Energy Projects (MNR 2011a);
- Significant Wildlife Habitat Technical Guide (MNR 2000); and
- Draft SWH Ecoregion 6E Criterion Schedule (MNR 2012).

Provincial designations for Special Concern species were obtained from the most recent Committee on the Status of Species at Risk in Ontario (COSSARO 2010) assessments. Federally, designations for Endangered, Threatened and Special Concern species were obtained from the most recent Committee on the Status of Endangered Wildlife in Canada (COSEWIC 2010)

assessments and the schedules of the *Species at Risk Act* (SARA) were used to determine species protection.

Within the context of O. Reg 359/09, Endangered and Threatened species are addressed as part of MNR's *Approval and Permitting Requirements Document for Renewable Energy Projects* (APRD) requirements and are therefore not included as part of this NHA. Information required with regards to endangered and threatened species is being submitted to MNR under separate cover as part of the Amherst Island Wind Energy Project APRD Report. Where this information indicates that approvals or permits are required, these will be addressed separately through the applicable statute and its permitting process.

4.1.1 Wetlands

For the purposes of this evaluation, wetlands previously identified and confirmed by MNR as provincially significant or locally significant are considered to meet the requirements for a determination of significance. Unless field investigations provided evidence to contradict the existing MNR assessment of significance, the designation as assigned by MNR is used. Wetland boundaries as delineated by MNR were confirmed during site investigations by an Ontario Wetland Evaluation System (OWES) trained evaluator. Boundaries as delineated during field investigations were considered accurate for the purposes of this report; however, additional wetland ELC polygons surrounding the two PSWs (Nut Island Duck Club Marsh and Long Point Marsh) were identified, which were included in the final boundaries for these two wetlands (**Table 5B, Appendix A**).

During site investigations additional wetland communities were identified within 120 m of the Project Location. Data were collected through desktop procedures (e.g. aerial photograph interpretation) to supplement on-site field investigations. The Wetland Characteristics and Ecological Functions Assessment (WCEFA) for Renewable Energy Projects approach provided in Appendix C of the NHA Guide for Renewable Energy Projects (MNR 2011a) was used to assess previously-unevaluated wetlands identified in LIO (LIO 2012) and to assess additional wetlands identified during field investigations. Although this procedure does not evaluate the significance of these wetlands with the same level of rigour as the OWES, it provides a procedure by which the significance of these wetlands can be assumed and their functions assessed based on the criteria established within the OWES manual.

4.1.2 Woodlands

Guidance provided in Section 6.2.2 of the NHA Guide for Renewable Energy Projects (MNR 2011a) was used to evaluate woodlands. The local planning authority has a responsibility for designating significant woodlands, using criteria that are provided in the NHA Guide. The Study Area falls within the Township of Loyalist within the County of Lennox and Addington. For woodlands on Amherst Island, the CRCA study utilized a 4 ha minimum threshold when determining significance based on size. This 4 ha threshold was determined based on the 5–15% total percent woodland cover on Amherst Island alone as opposed to the total woodland cover within Loyalist Township. As described in **Section 3.2.3**, 32 woodlands were located within 120 m of the Project Location, and required an Evaluation of Significance.

4.1.3 Wildlife and Wildlife Habitat

Although specific site visits are assigned to target particular groups (i.e. amphibians, reptiles, birds), all visits were conducted by qualified ecologists. All observations made over the duration

of the field program are compiled within the list of wildlife for the Study Area and are considered in the assessment of wildlife use of the site.

Given a review of available background information and an analysis of candidate significant wildlife habitat components that occurred in or within 120 m of the Project Location, a four-season pre-construction field survey program was conducted.

Collectively, these multiple surveys, the habitats they cover, and the period over which they occur (season and time of day) offer a comprehensive set of field observations for fauna species on site. Methods for evaluating candidate significant wildlife habitats are shown in **Tables 4.1** and **Table 4.3**.

Table 4.1: Criteria and Methods Used to Evaluate Seasonal Concentration Areas of Animals

Candidate Seasonal Concentration Area	Criteria	Methods	Seasonal Timing
<p>Shorebird Migratory Stopover Area</p>	<ul style="list-style-type: none"> • Presence of 3 or more of listed species (Greater Yellowlegs, Lesser Yellowlegs, Marbled Godwit, Hudsonian Godwit, Black-bellied Plover, American Golden Plover, Semipalmated Plover, Solitary Sandpiper, Spotted Sandpiper, Semipalmated Sandpiper, Pectoral Sandpiper, White-rumped Sandpiper, Baird's Sandpiper, Least Sandpiper, Purple Sandpiper, Stilt Sandpiper, Short-billed Dowitcher, Red-necked Phalarope, Whimbrel, Ruddy Turnstone, Sanderling, Dunlin) and >1000 shorebird use days during spring or fall migration period • >100 Whimbrel for 3 or more years is considered significant 	<ul style="list-style-type: none"> • Studies were completed during the spring migratory season. Evaluation methods followed "Bird and Bird Habitats: Guidelines for Wind Power Projects" for stopover driving transects and point counts • Stopover counts were conducted by driving a set transect, stopping at candidate habitats and conducting shorebird counts to estimate numbers and species • Counts were timed to coincide with peak numbers (dates and times) 	<ul style="list-style-type: none"> • April-May
<p>Raptor Wintering Area</p>	<ul style="list-style-type: none"> • One or more Short-eared Owls or at least 10 individuals of two of the listed species (Rough-legged Hawk, Red-tailed Hawk, Northern Harrier, American Kestrel, and Snowy Owl) • Site must be used regularly (3 in 5 years) for a minimum of 20 days 	<ul style="list-style-type: none"> • Studies were completed during the winter roosting season. Evaluation methods followed MNR protocols for raptor wintering area surveys • Walking transects were conducted along the interface of upland and forest transects once per week at each location, during daylight hours • Driving transects were also conducted between habitats to supplement data 	<ul style="list-style-type: none"> • November - March

Table 4.2: Criteria and Methods Used to Evaluate Habitat for Species of Conservation Concern

Candidate Habitat for Species of Conservation Concern	Criteria	Methods	Seasonal Timing
Open Country Bird Breeding Habitat	<ul style="list-style-type: none"> • Presence of nesting or breeding of 2 or more of the listed species (Upland Sandpiper, Grasshopper Sparrow, Vesper Sparrow, Northern Harrier, Savannah Sparrow) or a field with 1 or more breeding Short-eared Owl is considered significant wildlife habitat • Area of the significant wildlife habitat is contiguous ELC ecosite field areas • Swallow migratory staging is not included in the draft Ecoregion 6E Criteria as a significant wildlife habitat, but for the purposes of this study, it was included under open country breeding bird habitat as providing the ecological functions required for staging swallows 	<ul style="list-style-type: none"> • Studies were completed in spring and early summer when birds were singing and defending their territories. Evaluation methods followed “Bird and Bird Habitats: Guidelines for Wind Power Projects” for standardized point counts and line transects • Staging swallow surveys were conducted during fall migration when swallows are migrating south, staging before crossing Lake Ontario. • Standardized point counts and walking transects were conducted within the candidate habitat during the early morning hours. 	<ul style="list-style-type: none"> • May-June (grassland birds) • July-September (staging swallows)
Shrub/Early Successional Bird Breeding Habitat	<ul style="list-style-type: none"> • Presence of nesting or breeding of 1 of the indicator species (Brown Thrasher, Clay-coloured Sparrow) and at least 2 of the common species (Field Sparrow, Black-billed Cuckoo, Eastern Towhee, Willow Flycatcher), or a field with breeding Yellow-breasted Chat or Golden-winged Warbler is considered significant • Area of the significant wildlife habitat is the contiguous ELC ecosite field/thicket area 	<ul style="list-style-type: none"> • Studies were completed in spring and early summer when birds were singing and defending their territories. Evaluation methods followed “Bird and Bird Habitats: Guidelines for Wind Power Projects” for standardized point counts and line transects • Standardized point counts and walking transects were conducted within the candidate habitat during the early morning hours 	<ul style="list-style-type: none"> • May-June

5.0 ENVIRONMENTAL IMPACT STUDY

5.4 Other General Construction Mitigation

To fully identify all mitigation measures that are recommended for this development, the following section provides best management practices and other measures intended to minimize or mitigate potential adverse impacts on adjacent significant natural features. These measures will be implemented, where required and reasonable, during the construction and decommissioning of the various turbines, access roads and collector lines.

5.4.1 Vegetation Removal

Natural features where habitat will be removed include grasslands, wetlands and scattered trees. Where vegetation removal is proposed, the following mitigation measures will be applied:

- As appropriate, and prior to construction, the limits of vegetation clearing will be staked in the field. The Construction Contractor will ensure that no construction disturbance occurs beyond the staked limits and that edges of sensitive areas adjacent to the work areas are not disturbed. Regular monitoring of the limits of clearing will be implemented to ensure the objective of minimal disturbance. Should monitoring reveal that clearing occurred beyond defined limits, mitigation action will be taken that could include rehabilitation of the disturbed area to pre-disturbance conditions at the direction of a qualified ecologist (with enhancement of any disturbed areas).
- To the extent practical, tree and/or brush clearing and grassland removal will be completed prior to, or after, the core nesting season for breeding birds (May 1 to July 31). Should clearing be required during the breeding bird season, prior to construction, surveys will be undertaken by a qualified biologist to identify the presence/absence of nesting birds or breeding habitat. If a nest is located, a designated buffer will be marked off within which no construction activity will be allowed while the nest is active. The radius of the buffer will range from 5 - 60 m, depending on the species. Buffer widths are based on the species' sensitivity and on buffer width recommendations that have been reviewed and approved by Environment Canada.
- Prior to the start of construction activity, the topsoil/seedbank will be stripped and preserved; material will be reapplied in suitable rehabilitation areas post construction.
- Excavated soil from crane pads will be re-used on site, as feasible. If not feasible, the soil will be disposed of at an approved off-site facility. Temporary laydown areas will be returned to pre-construction conditions.
- Following construction, topsoil in areas of temporary disturbance will be replaced/restored. Disturbed areas in agricultural fields will be reseeded with a hay mix. Disturbed areas in wetlands 6 and 7 will be reseeded with a native wetland grass mix. Reseeded areas will be monitored for one year to ensure regeneration success.

5.4.2 Sediment and Erosion Control Measures

In order to minimize erosion and the introduction of sediment into significant natural features during grading and construction activities, erosion and sediment (E&S) control measures will be implemented prior to the initiation of any construction.

The proximity of adjacent significant natural features increases the risk of sedimentation within a construction area. As such, all significant natural features identified within 30 m of any proposed construction area are at higher risk of sediment transfer and erosion from grading and topsoil removal.

E&S control measures will be installed to minimize erosion impacts adjacent to significant natural features, as appropriate. The following measures/guidelines will be implemented, as required, during the construction of the Amherst Island Wind Project components:

- Sediment control measures, which may include perimeter silt fencing, mud mats (access roads), check dams (rock or straw bales), and sediment bags (dewatering);
- Silt barriers (e.g., fencing) will be erected along wetland and woodland community edges located within 30 m of construction areas (including staging areas and laydown areas) to

minimize potential sediment transport to the significant natural features. These barriers will be regularly monitored and properly maintained during and following construction until soils in the construction area are re-stabilized with vegetation; and

- Where culverts are proposed within 30 m of a significant natural feature, enhanced sediment and erosion control measure (i.e. straw bales, double rows of sediment fencing, check dams) will be installed as added protection to filter runoff and further minimize potential sedimentation within the downstream features (wetland, woodland). This added protection is proposed to reduce environmental risk.

Specific E&S control measures will be selected, located and sized by an engineer during the detailed design stage to ensure proper functioning of these measures. All E&S controls will be installed prior to construction and will be maintained during and following construction to ensure their effectiveness at protecting the adjacent significant natural features.

5.4.3 Dewatering

Site specific geotechnical investigations to be completed prior to construction activities will provide further details related to geologic conditions. Dewatering requirements will be re-assessed as part of the geotechnical investigations.

If groundwater is encountered during excavations, good construction practices will be used, such as minimizing the length of time that the excavation is open and monitoring seepage into the excavation. Should pumping be required to dewater excavated areas, water will be directed into the nearest drain or spread across the buildable area and appropriate energy dissipation techniques will be used to reduce the potential for erosion and scouring. Discharge piping will be free of leaks and will be properly anchored to prevent bouncing and snaking during surging. The rate of discharge will be monitored to ensure no erosion or flooding occurs. If energy dissipation measures are found to be inadequate, the rate of dewatering will be reduced or ceased until satisfactory mitigation measures are in place.

In order to mitigate any impacts to significant natural features during dewatering activities, the following measures will be implemented, as required and necessary:

- The area to be used for dewatering will be clearly marked with flagging and/or snow-fencing prior to work commencing;
- During site preparation, silt fencing will be included to retain sediments on site so they do not enter any significant natural feature. All sediment control structures will be inspected regularly, and repaired/maintained as necessary;
- All water pumped during dewatering activities will be directed away from significant natural features and not directly into wetlands;
- The use of sediment bags (or filter rings) will be used as appropriate to filter out suspended sediment prior to discharge. Any sediment bags or filter rings will be monitored during pumping to ensure their efficacy, with any clogging or failures to be rectified immediately; and
- After the staging area and dewatering work area is no longer required, any remaining disturbed soils will be returned to pre-disturbance conditions and/or reseeded.

Further dewatering recommendations will be reviewed upon the completion of the detailed engineering design. Additional detail is provided in the Amherst Island Construction Plan Report (separate cover, Stantec 2012b).

5.4.4 Other General Mitigation Measures

Table 5.1 summarizes the general mitigation measures which will be implemented during construction, including the mitigation objective and specific location where each mitigation measure should be applied.

Mitigation Measure	Objective(s)	Location(s)
Any vegetation removal required along roadside collector lines should be minimized, and occur entirely within the road right-of-way.	Minimize vegetation removal and impacts on wildlife habitats	Underground Collector Lines/ or overhead collector lines
Any accidentally damaged trees should be pruned through the implementation of proper arboricultural techniques.	Protect tree species from permanent damage	Entire Project
Suspend work if high runoff volume is noted or excessive sediment discharge occurs.	Minimize erosion impacts on features when construction activities are proposed within 30 m of significant natural features	Within 30 m of any significant feature, including significant woodlands and wetlands and significant wildlife habitat*
No vehicle traffic on exposed soils, and no heavy machinery traffic on slopes	Limit unnecessary risk of increased erosion, turbidity or sedimentation	Entire Project
Re-vegetate temporary access roads or crane paths to pre-construction conditions as soon as possible.	Limit the potential for erosion or sedimentation due to exposed soil conditions	Entire Project
Maintain existing vegetation buffers around water bodies	Minimize the potential for erosion, and protect wildlife habitat, within riparian areas	Entire Project
Any stockpiled material will be stored more than 30 m from a significant wetland, woodland, or water body	Limit the potential for increased erosion within 30 m of significant natural features	Entire Project
All maintenance activities, vehicle refueling or washing, and chemical storage will be located more than 30 m from any significant feature.	Minimize the risk of contamination of chemical spill around significant natural features	Entire Project
Develop a spill response plan, train staff on appropriate procedures, and keep emergency spill kits on site.	Minimize potential long-term effects or significant contaminations in the event an accidental spill occurs	Entire Project
Dispose of waste material by authorized and approved offsite vendors	Limit the potential for contamination of significant natural features	Entire Project
Implement infiltration techniques to the maximum extent possible.	Minimize potential impacts to soil moisture regime and	Entire Project

Table 5.1: Summary of Construction Phase Mitigation Measures Recommended

Mitigation Measure	Objective(s)	Location(s)
	groundwater stores	
Design roads to promote infiltration.	Minimize potential impacts to soil moisture regime and groundwater stores	Entire Project
No herbicides will be used within significant features or wildlife habitats.	Avoid impacts to natural vegetation species, significant features, and wildlife habitats	Significant woodlands and wetlands, and significant wildlife habitat*
Minimize grading activities to maintain existing drainage patterns, to the fullest extent possible.	Maintain existing surface water drainage patterns	Entire Project
Control rate and timing of water pumping, and restrict taking of water during periods of extreme low flow.	Limit potential impacts on water temperature, surface water storage, and wildlife habitat	Entire Project
Implementation of storm water discharge best management practices.	Avoid potential contamination of water sources	Entire Project
Collect drill cuttings as they are generated and placed in a soil bin or bag for off-site disposal	Limit the potential for soil or water contamination	Horizontal Directional Drilling
Restore and re-vegetate entry/exit pits to pre-construction conditions as soon as possible after construction	Minimize the presence of exposed soil to reduce the potential for erosion	Horizontal Directional Drilling

* Only if these habitats evaluated as significant in this report or are determined to be significant through pre-construction surveys described in **Section 5.6.3.3**

Appendix E:
Correspondence with MTCS



Stantec Consulting Ltd.
70 Southgate Drive, Suite 1, Guelph ON N1G 4P5

December 2, 2014
File: 160960595

Attention: Paige Campbell
Ministry of Tourism, Culture and Sport
435 S. James Street, Suite 334
Thunder Bay ON P7E 5S7

Dear Ms. Campbell ,

**Reference: Amherst Island Wind Energy
Project Layout Modifications**

The purpose of this letter is to provide the Ministry of Tourism, Culture and Sports (MTCS) with details regarding proposed project layout modifications to the Amherst Island Wind Energy Project (the "Project"). Please accept this correspondence as a formal request for your office to expedite the review of the information described below due to the fact that a modification submission to the Ministry of the Environment and Climate Change (MOECC) is required as soon as possible to meet the Project schedule.

These Project updates have been discussed with the MOECC, who has verified the proposed modifications would be classified as Technical Changes and a Project Design Change, pursuant to the classification system outlined in the Ministry of the Environment's Technical Guide to Renewable Energy Approvals (October, 2013).

The amendments include the following:

- a) The reduction in the number of Wind Turbines by changing the Turbine Model (Siemens 2.942 MW and 2.772 MW) (see **Figure 1A, Attachment 1**);
- b) The addition of an underground collector line along a previously approved access road between T16/T23 and T35 (see **Figure 1A, Attachment 1**); and
- c) The addition of an underground collector line along South Shore Road and up to S13 (see **Figure 1, Attachment 1**). Along with the removal of the portions of the proposed underground collector line along Stella 40 Foot Road and Front Road.

Amendment Details

Technical Change Modifications:

- a) Reducing the number of Wind Turbines by changing Turbine Model (Siemens 2.942 MW and 2.772 MW)

Design with community in mind



December 2, 2014
Paige Campbell
Page 2 of 3

**Reference: Amherst Island Wind Energy
Project Layout Modifications**

This technical change involves changing the Project's turbines from a combination of Siemens 2.3 MW and 2.221 MW to a combination of Siemens 2.942 MW and 2.772 MW, and thereby reducing the number of turbines from 36 to 27. The new turbines would be physically identical, specifically with a hub height of 99.5 m and rotor diameter of 113 m. The modification will decrease the Project Location size by reducing the number of turbine sites from 36 to 27. All of these 27 turbine sites are in previously studied and proposed locations.

b) Collection System Route Change – Reducing Impacts on 2nd Concession

Another technical change would involve the addition of an underground collector line along a previously approved access road between T16/T23 and T35. This underground collector line has been incorporated into the design of the access road between T16/23 and T35. Because the collector line will use the same corridor as the previously studied and proposed access road, the Project Location will not be changed, and therefore there will be no new features to be considered within 120 m of the Project Location. The addition of the underground collector line route provides Windlectric Inc. with greater design flexibility. The construction and installation activities for this underground collector line will be completed in the same manner as the collector lines which are described in the Construction Plan Report, submitted as part of the Renewable Energy Approval (REA) Application.

The two technical amendments described above do not require additional Stage 2 archaeological assessments.

Project Design Change Modifications:

c) Collection System Route Change – Avoiding the Village of Stella

This proposed modification would involve rerouting the collection system to avoid the Village of Stella. In doing so, this modification would remove a significant portion of the existing collection system from S30 entrance along Front Road, including removing approximately 4 km of road allowance trenching (including through Stella). The modification would also require a new collection corridor from S13 to South Shore Rd. and west to S14 entrance, which would consist of approximately 1 km in road allowance and 700 m of in pasture field. The modification will decrease the Project Location size by resulting in a net reduction of approximately 2 km of collection system trenching.

The project modification has been discussed with the Ministry of the Environment and Climate Change (MOECC). The MOECC has verified this project modification is a Project Design Change



December 2, 2014
Paige Campbell
Page 3 of 3

**Reference: Amherst Island Wind Energy
Project Layout Modifications**

as pursuant to the classification system outlined in the Ministry of the Environment's *Technical Guide to Renewable Energy Approvals* (October, 2013).

Additional Stage 2 archaeological work was necessary to determine the presence of potential archaeological resources on the manicured private lawn (lot 13) south of Turbine S13. This work was undertaken and is described in the attached report titled: Attachment 2: Stage 2 Archaeological Assessment: Amherst island Wind Energy Project, Collector Line Modification.

The results of the Stage 2 work indicates no archaeological resources were identified during the field assessment, therefore, no further archaeological assessment of the study area is required.

CLOSING

Stantec Consulting Ltd. prepared this letter report for Windlectric Inc. for the Amherst Island Wind Energy Project. Windlectric Inc. is committed to implementing the appropriate protection and mitigation measures as they apply to the construction and operation of the proposed Project.

Regards,

STANTEC CONSULTING LTD.

A handwritten signature in blue ink that reads "Kerrie Skillen".

Kerrie Skillen
Project Manager
Phone: (519) 836-6966
kerrie.skillen@stantec.com

c. Alex Tsopelas, Algonquin Power Co.
Sean Fairfield, Algonquin Power Co.
Colin Varley, Stantec Consulting Ltd.

Attachments:

Attachment 1: Project Location & Study Area: Proposed Modifications
Attachment 2: Stage 2 Archaeological Assessment: Amherst island Wind Energy Project, Collector Line Modification

ks \\cd1220-f02\work_group\01609\active\60960595\reports\03_modification reports\rep_modification_no. 3_draft\arch assessment modifications\ltr_60595_aiwip-aa_tcand pdc_20141128_final.docx

Attachment 1:

Project Location & Study Area: Proposed Modifications

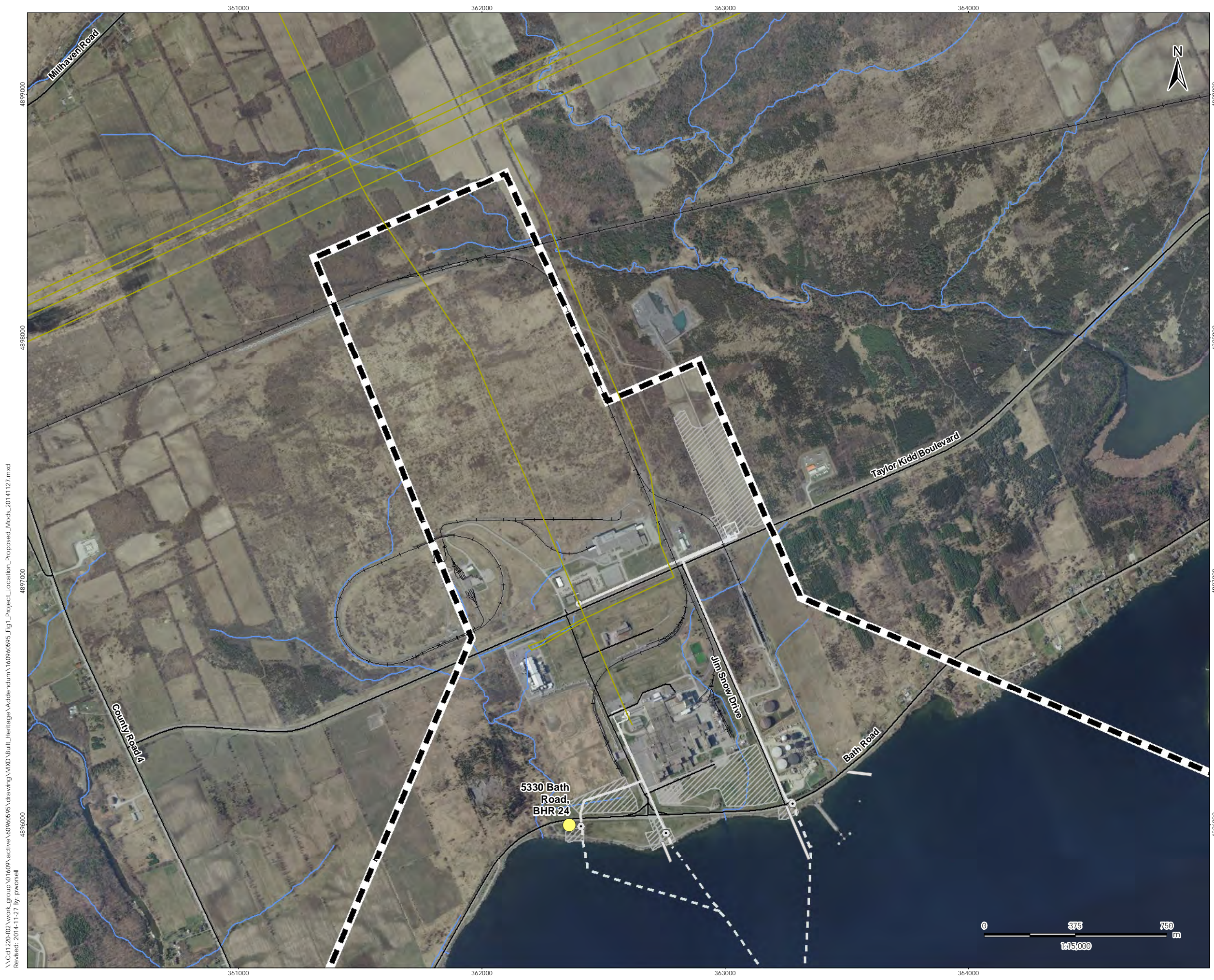

Legend

- Study Area
- Built Heritage Resource
- Protected Property
- Cultural Heritage Landscape
- Stone Fence
- Project Components**
- ⊙ Turbine (No Changes Proposed)
- ⊘ Turbine (Removed)
- ⊙ Met Tower - Potential Location (No Changes Proposed)
- ⊘ Met Tower - Potential Location (Removed)
- Other Project Component (No Changes Proposed)
- Other Project Component (New)
- Other Project Component (Removed)
- Existing Features**
- Road
- Unopened Road Allowance
- Railway
- Hydro Line
- Watercourse
- Property Line

Notes

1. Coordinate System: NAD 1983 UTM Zone 18N
2. Base features produced under license with the Ontario Ministry of Natural Resources © Queen's Printer for Ontario, 2014.
3. Orthoimagery © First Base Solutions, 2014. Imagery taken in 2008.

November 2014
160960595

Client/Project

Windlectric Inc.
Amherst Island Wind Energy Project

Figure No.

1.1

Title

Project Location & Study Area:
Proposed Modifications



\\Cd1220-102\work_group\01609\active\60960595\drawing\MXD\Built_Heritage\Addendum\160960595_Fig1_Project_Location_Proposed_Mods_20141127.mxd
 Revised: 2014-11-27 By: p.worsell

Legend

- Study Area
- Built Heritage Resource
- Protected Property
- Cultural Heritage Landscape
- Stone Fence
- Project Components**
- Turbine (No Changes Proposed)
- Turbine (Removed)
- Met Tower - Potential Location (No Changes Proposed)
- Met Tower - Potential Location (Removed)
- Other Project Component (No Changes Proposed)
- Other Project Component (New)
- Other Project Component (Removed)
- Existing Features**
- Road
- Unopened Road Allowance
- Railway
- Hydro Line
- Watercourse
- Property Line

Notes

1. Coordinate System: NAD 1983 UTM Zone 18N
2. Base features produced under license with the Ontario Ministry of Natural Resources © Queen's Printer for Ontario, 2014.
3. Orthoimagery © First Base Solutions, 2014. Imagery taken in 2008.

November 2014
160960595

Client/Project

Windlectric Inc.
Amherst Island Wind Energy Project

Figure No.

1.2

Title

Project Location & Study Area:
Proposed Modifications



\\C:\1220-102\work_group\01609\active\60960595\drawing\MXD\Built_Heritage\Addendum\160960595_Fig_1_Project_Location_Proposed_Mods_20141127.mxd
 Revised: 2014-11-27 By: pworsell

366000 367000 368000 369000 370000



Legend

- Study Area
- Built Heritage Resource
- Protected Property
- Cultural Heritage Landscape
- Stone Fence
- Project Components
 - Turbine (No Changes Proposed)
 - Turbine (Removed)
 - Met Tower - Potential Location (No Changes Proposed)
 - Met Tower - Potential Location (Removed)
 - Other Project Component (No Changes Proposed)
 - Other Project Component (New)
 - Other Project Component (Removed)
- Existing Features
 - Road
 - Unopened Road Allowance
 - Railway
 - Hydro Line
 - Watercourse
 - Property Line

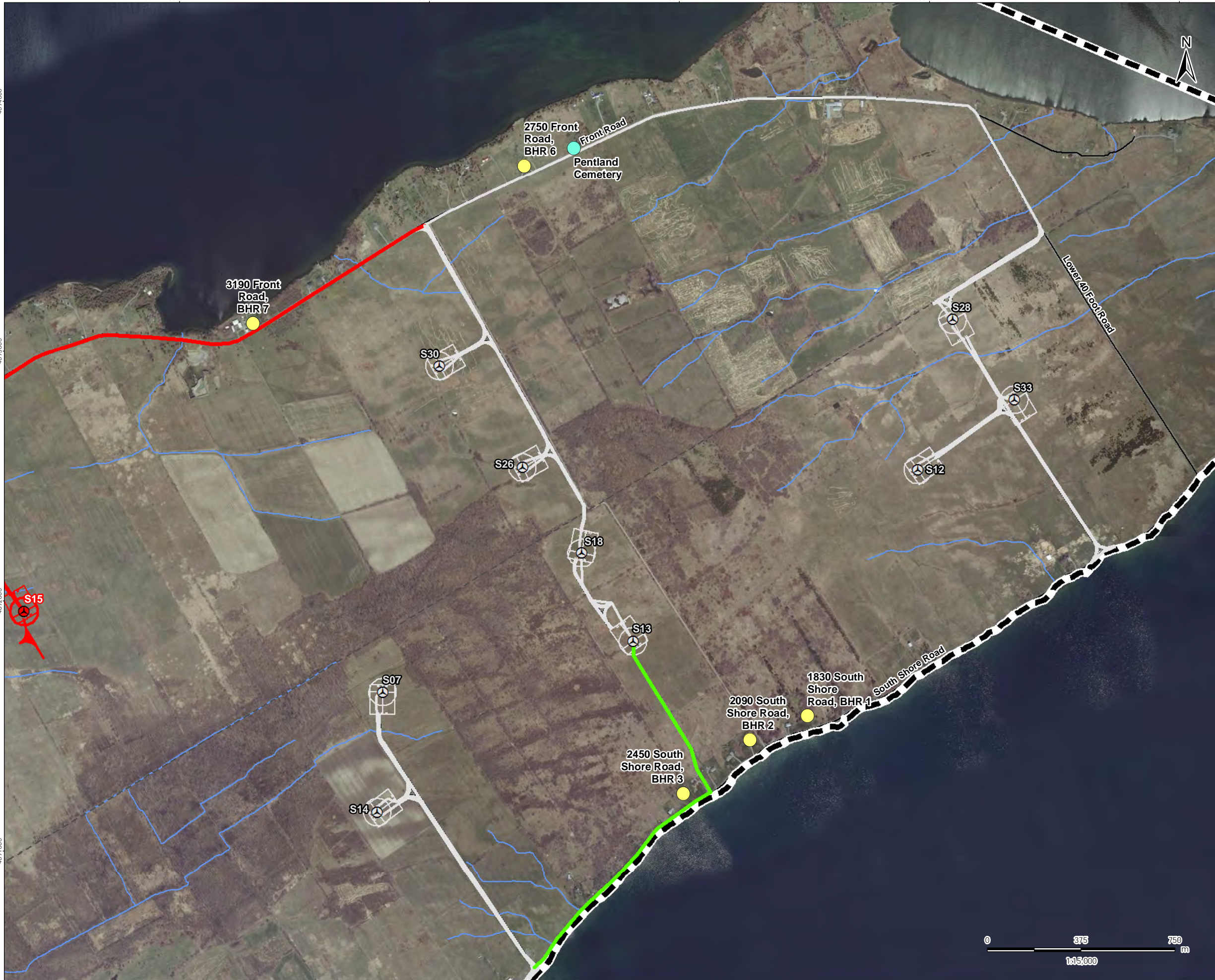

Notes

1. Coordinate System: NAD 1983 UTM Zone 18N
2. Base features produced under license with the Ontario Ministry of Natural Resources © Queen's Printer for Ontario, 2014.
3. Orthoimagery © First Base Solutions, 2014. Imagery taken in 2008.

November 2014
160960595

Client/Project
Windlectric Inc.
Amherst Island Wind Energy Project

Figure No.
1.3

Title
Project Location & Study Area:
Proposed Modifications



366000 367000 368000 369000 370000

\\C:\1220-102\work_group\01609\active\60960595\drawing\MXD\Built_Heritage\Addendum\160960595_Fig1_Project_Location_Proposed_Mods_20141117.mxd
 Revised: 2014-11-27 By: p.worsell

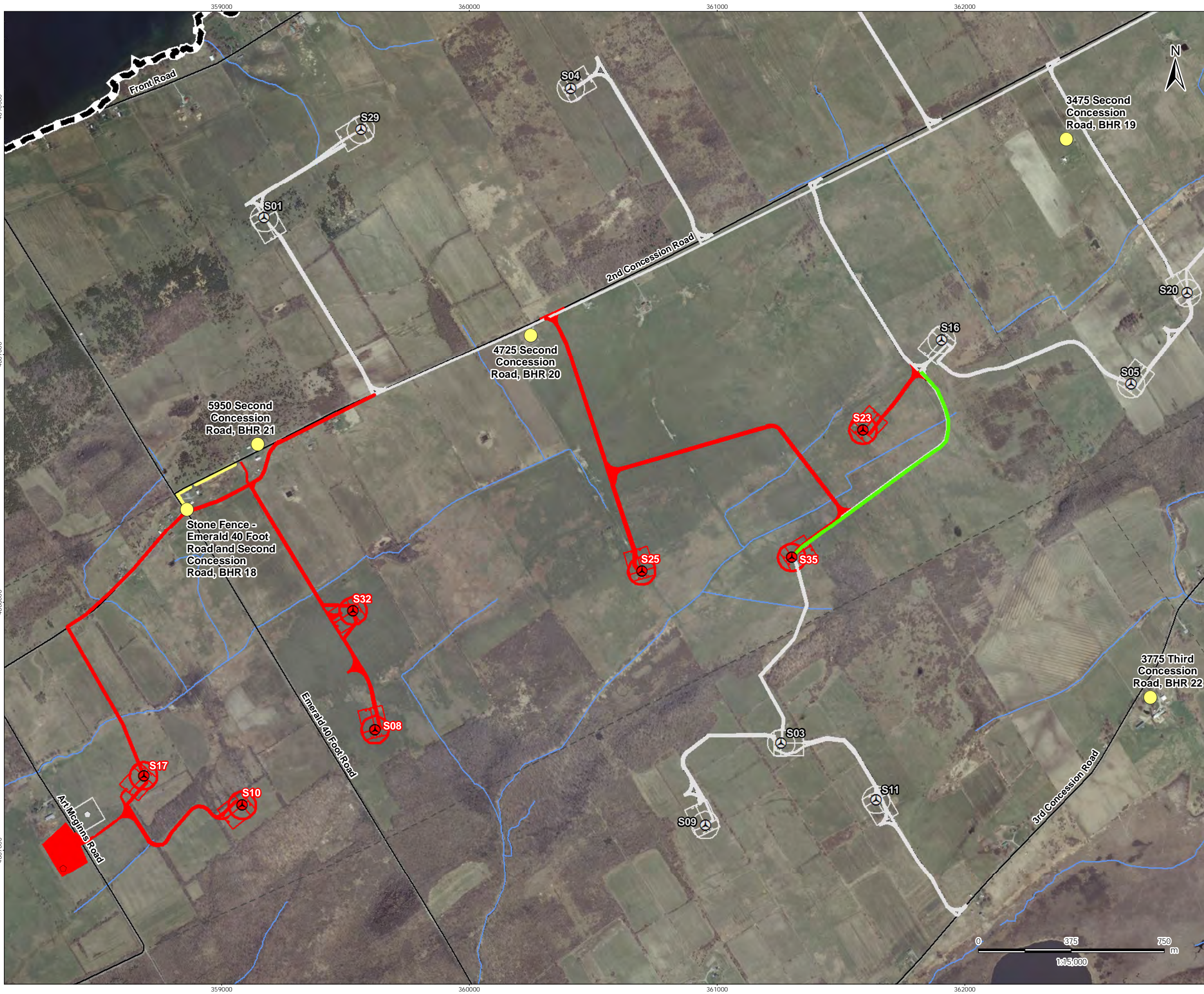

Legend

- Study Area
- Built Heritage Resource
- Protected Property
- Cultural Heritage Landscape
- Stone Fence

Project Components

- Turbine (No Changes Proposed)
- Turbine (Removed)
- Met Tower - Potential Location (No Changes Proposed)
- Met Tower - Potential Location (Removed)
- Other Project Component (No Changes Proposed)
- Other Project Component (New)
- Other Project Component (Removed)

Existing Features

- Road
- Unopened Road Allowance
- Railway
- Hydro Line
- Watercourse
- Property Line

Notes

1. Coordinate System: NAD 1983 UTM Zone 18N
2. Base features produced under license with the Ontario Ministry of Natural Resources © Queen's Printer for Ontario, 2014.
3. Orthoimagery © First Base Solutions, 2014. Imagery taken in 2008.

November 2014
160960595

Client/Project
Windlectric Inc.
Amherst Island Wind Energy Project

Figure No.
1.4

Title
Project Location & Study Area:
Proposed Modifications

\\C:\1220-102\work_group\01609\active\60960595\drawing\MXD\Built_Heritage\Addendum\160960595_Fig1_Project_Location_Proposed_Mods_20141127.mxd
 Revised: 2014-11-27 By: p.worsell



Legend

- Study Area
- Built Heritage Resource
- Protected Property
- Cultural Heritage Landscape
- Stone Fence
- Project Components**
- Turbine (No Changes Proposed)
- Turbine (Removed)
- Met Tower - Potential Location (No Changes Proposed)
- Met Tower - Potential Location (Removed)
- Other Project Component (No Changes Proposed)
- Other Project Component (New)
- Other Project Component (Removed)
- Existing Features**
- Road
- Unopened Road Allowance
- Railway
- Hydro Line
- Watercourse
- Property Line

Notes

1. Coordinate System: NAD 1983 UTM Zone 18N
2. Base features produced under license with the Ontario Ministry of Natural Resources © Queen's Printer for Ontario, 2014.
3. Orthoimagery © First Base Solutions, 2014. Imagery taken in 2008.

November 2014
160960595

Client/Project

Windlectric Inc.
Amherst Island Wind Energy Project

Figure No.

1.5

Title

Project Location & Study Area:
Proposed Modifications

\\Cd1220-102\work_group\01609\active\60960595\drawing\MXD\BUILT_Heritage\Addendum\160960595_Fig1_Project_Location_Proposed_Mods_20141127.mxd
 Revised: 2014-11-27 By: pwnorsell
 4887000

Attachment 2:

Stage 2 Archaeological Assessment:
Amherst island Wind Energy Project, Collector Line Modification

**Stage 2 Archaeological
Assessment: Amherst Island
Wind Energy Project, Collector
Line Modification**

Part of Lot 13, South Shore
Concession, Amherst Island,
County of Lennox and
Addington, Ontario



Prepared for:
Windlelectric Inc.
2845 Bristol Circle
Oakville, Ontario L6H 7H7

Prepared by:
Stantec Consulting Ltd.
1331 Clyde Ave, Suite 400
Ottawa, ON K2C 3G4

Licensee: Patrick Hoskins, MA
License Number: P415
PIF Number: P415-0020-2014
Project Number: 160960595

FIT Number: FUT3NOX

ORIGINAL REPORT

December 1, 2014

Table of Contents

EXECUTIVE SUMMARY	III
PROJECT PERSONNEL	IV
ACKNOWLEDGEMENTS.....	IV
1.0 PROJECT CONTEXT.....	1.1
1.1 DEVELOPMENT CONTEXT	1.1
1.1.1 Objectives.....	1.2
1.2 HISTORICAL CONTEXT	1.2
1.2.1 Post-contact Aboriginal Resources.....	1.2
1.2.2 Euro-Canadian Resources	1.3
1.2.3 Recent Reports	1.4
1.3 ARCHAEOLOGICAL CONTEXT.....	1.5
1.3.1 The Natural Environment	1.5
1.3.2 Pre-contact Aboriginal Resources	1.5
1.3.3 Previously Known Archaeological Sites and Surveys.....	1.10
1.3.4 Existing Conditions	1.11
2.0 FIELD METHODS	2.1
3.0 RECORD OF FINDS.....	3.1
4.0 ANALYSIS AND CONCLUSIONS	4.1
5.0 RECOMMENDATIONS.....	5.1
6.0 ADVICE ON COMPLIANCE WITH LEGISLATION.....	6.1
7.0 BIBLIOGRAPHY AND SOURCES	7.1
8.0 IMAGES.....	8.1
8.1 PHOTOS	8.1
9.0 MAPS	9.1
10.0 CLOSURE.....	10.1

STAGE 2 ARCHAEOLOGICAL ASSESSMENT: AMHERST ISLAND WIND ENERGY PROJECT, COLLECTOR LINE MODIFICATION

LIST OF TABLES

Table 1: Southern Ontario Prehistoric Cultural Chronology, Years Before Present (BP) ... 1.5
Table 2: Field and Weather Conditions 2.1
Table 3: Inventory of the Documentary Record 3.1

LIST OF FIGURES

Figure 1: Site Location 9.2
Figure 2: Site Plan 9.3
Figure 3: Meacham's 1878 Historic Mapping Overlaid by Project Components 9.4
Figure 4: Location of Stage 2 AA Testing 9.5
Figure 5: Stage 2 Assessment Results 9.6



Executive Summary

Stantec Consulting Ltd. (Stantec) was retained by Windlectric Inc. to complete a Stage 2 assessment of a proposed, Collector Line Modification for a section of the Amherst Island Wind Energy Project, located on part of Lot 13, South Shore Concession, Amherst Island, County of Lennox and Addington, Ontario. Windlectric Inc. (the Proponent or Windlectric) is proposing to develop, construct, and operate the 56 - 75 megawatt (MW) Amherst Island Wind Energy Project within Loyalist Township in the County of Lennox and Addington in eastern Ontario, in response to the Government of Ontario's initiative to promote the development of renewable electricity in the province.

The basic components of the proposed Project include up to 36 Siemens wind turbines. The final layout will result in a total installed nameplate capacity of approximately 56 - 75 MW. The number of wind turbines will be dependent upon final selection of the model of the wind turbine most appropriate to the proposed Project.

The proposed Project will also include a 34.5 kilovolt (kV) underground and/or overhead electrical power line collector system, fibre optic data lines from each turbine and/or wireless technology for the communication of data, a transmission line, truck turnaround areas, a submarine cable, an operations and maintenance building, permanent dock, a substation, a switching station, an un-serviced storage shed, one connection point to the existing electrical system, cable vault areas, meteorological tower(s) (met tower(s)), access road(s) to the met tower site(s), and turbine access roads with culvert installations, as required, at associated watercourse crossings.

The Stage 2 archaeological assessment was conducted October 24, 2014 under PIF #P415-0020-2014 issued to Patrick Hoskins, MA, by the Ministry of Tourism, Culture and Sport (MTCS). An area approximately 90 metres north-south by 15 metres east-west was assessed during the Stage 2 archaeological assessment conducted on behalf of Winelectric Inc.

The Stage 2 archaeological assessment resulted in the identification of no archaeological resources, and therefore **it is recommended that no further archaeological assessment of the study area is required.**

The Ministry of Tourism, Culture and Sport is asked to accept this report into the Ontario Public Register of Archaeological Reports.

The Executive Summary highlights key points from the report only; for complete information and findings, the reader should examine the complete report.



STAGE 2 ARCHAEOLOGICAL ASSESSMENT: AMHERST ISLAND WIND ENERGY PROJECT, COLLECTOR LINE MODIFICATION

Project Personnel

Licensed Archaeologist:	Patrick Hoskins, MA (P415)
Project Manager:	Colin Varley, MA, RPA Associate, Senior Archaeologist (P002)
Licensed Field Directors:	Tavis Maplesden, BA (R467)
Field Technicians:	Patrick Hokins, MA (P415)
Report Writer:	Patrick Hoskins, MA (P415)
GIS Specialist:	Nicole Cruikshank, B.Sc. CertGIS
Technical Review:	Colin Varley, MA, RPA (P002)
Senior Review:	Jim Wilson, MA, Archaeology Discipline Lead, (P001)

Acknowledgements

Ministry of Tourism, Culture and Sport: Mr. Robert von Bitter



STAGE 2 ARCHAEOLOGICAL ASSESSMENT: AMHERST ISLAND WIND ENERGY PROJECT, COLLECTOR LINE MODIFICATION

Project Context
December 1, 2014

1.0 PROJECT CONTEXT

1.1 DEVELOPMENT CONTEXT

Stantec Consulting Ltd. (Stantec) was retained by Windlectric Inc. to complete a Stage 2 assessment of a proposed Collector Line Modification for a section of the Amherst Island Wind Energy Project, located on part of Lot 13, South Shore Concession, Amherst Island, County of Lennox and Addington, Ontario (Figures 1 and 2). Windlectric Inc. (the Proponent or Windlectric) is proposing to develop, construct, and operate the 56 - 75 megawatt (MW) Amherst Island Wind Energy Project within Loyalist Township in the County of Lennox and Addington in eastern Ontario, in response to the Government of Ontario's initiative to promote the development of renewable electricity in the province.

The basic components of the proposed Project include up to 36 Siemens wind turbines. The final layout will result in a total installed nameplate capacity of approximately 56 - 75 MW. The number of wind turbines will be dependent upon final selection of the model of the wind turbine most appropriate to the proposed Project.

The proposed Project will also include a 34.5 kilovolt (kV) underground and/or overhead electrical power line collector system, fibre optic data lines from each turbine and/or wireless technology for the communication of data, a transmission line, truck turnaround areas, a submarine cable, an operations and maintenance building, permanent dock, a substation, a switching station, an un-serviced storage shed, one connection point to the existing electrical system, cable vault areas, meteorological tower(s) (met tower(s)), access road(s) to the met tower site(s), and turbine access roads with culvert installations, as required, at associated watercourse crossings.

Temporary components during construction may include staging areas for the turbines, access roads, met tower(s), collector lines and transmission line as well as crane paths, a temporary dock, site office(s), batch plant, central staging areas, and associated watercourse crossings. The electrical power line collector system would transport the electricity generated from each turbine to the substation, along the submarine cable to the mainland and then to a switching station located near to an existing Hydro One Networks Inc. (HONI) 115 kV transmission line.



STAGE 2 ARCHAEOLOGICAL ASSESSMENT: AMHERST ISLAND WIND ENERGY PROJECT, COLLECTOR LINE MODIFICATION

Project Context
December 1, 2014

The REA application considered the following alternative Project configurations:

- two alternative mainland transmission line routes;
- two alternative switching station locations and corresponding point of common coupling with the HONI line;
- three alternative mainland temporary dock locations along the mainland;
- a submarine cable with three alternative submarine cable routes near the mainland;
- three alternative mainland submarine cable landing locations and corresponding cable vault locations;
- up to three alternative met tower locations; and,
- up to three potential locations for an operations and maintenance building.

Final selection of the sites to be used would be based on the results of consultation activities, detailed design / engineering work, and the conditions experienced during construction.

This current Stage 2 assessment was required in order to assess the addition of an underground collector line along South Shore Road within the road right-of-way and on private land from the access road for S14 to S13. The rerouting of the proposed collector line would occur from the end of a previously surveyed section of the Project through a lawn area in Lot 13. The collector line will run south through the property to the disturbed road Right of Way at South Shore Road. The total width of the proposed project work will be maximally 10 m wide.

1.1.1 Objectives

The objectives of the Stage 2 archaeological assessment are to document archaeological resources present within the subject property, to determine whether any of the resources might be artifacts or archaeological sites with cultural heritage value or interest requiring further assessment, and to provide specific Stage 3 direction for the protection, management, and/or recovery of the identified archaeological resources (Government of Ontario 2011).

1.2 HISTORICAL CONTEXT

The study area comprises an area approximately 90 metres north-south by 15 metres east-west with in part of Lot 13, South Shore Concession, Amherst Island, County of Lennox and Addington.

1.2.1 Post-contact Aboriginal Resources

The study area is situated within the County of Lennox and Addington, Ontario. The area was subjected to the Crawford's Purchase in 1783. The purchase consisted of lands "...from the mouth of the Gananoque River to the mouth of the Trent River was purchased from the



STAGE 2 ARCHAEOLOGICAL ASSESSMENT: AMHERST ISLAND WIND ENERGY PROJECT, COLLECTOR LINE MODIFICATION

Project Context
December 1, 2014

Mississaug[a]... [and] includes the southern portions of the Counties of Hastings, Lennox and Addington, and Frontenac." (Morris 1943:16-17)

1.2.2 Euro-Canadian Resources

The following historical overview is based on that found in the Stage 1 AA report for the project (Stantec 2012). Originally part of the historic Midland District, the Counties of Lennox and Addington were created as part of the United Counties of Frontenac, Lennox and Addington by the 1792 decree of Governor John Graves Simcoe. In 1864, there was a further separation leading to what are now the two counties of Frontenac and of Lennox and Addington. Unlike other historic counties with multiple names, Lennox and Addington only ever existed as separate entities on paper and never needed to be united. The townships were named for Charles Lennox and Henry Addington, both members the British aristocracy and parliament.

The original settlers of the Lennox and Addington area were United Empire Loyalists (UEL), fleeing a post-Revolution United States for the relative safety of Canada in and around 1784. Prior to their arrival most of the land remained in wilderness and, as it had never been surveyed, little was known about its condition. The large numbers of Loyalists fleeing America for Nova Scotia and New Brunswick eventually caused a land shortage that forced the British to look for other areas to open. Thus, the north shore of Lake Ontario, from Kingston westward, was quickly surveyed and land allotments distributed (Herrington 1915). Initial land grants were for 200 acres per person with larger allotments given to those who had actively fought for the Crown in the Revolutionary War. Each applicant drew a number that corresponded with a certain parcel of land in one of the five 'Towns' laid out. It was their responsibility to clear and cultivate the land (Herrington 1913).

The first European claimant of Amherst Island (historically Isle de Tonti/Ile Tonti) was the French explorer Robert de la Salle (La Salle) who named it for his lieutenant Henri de Tonti. Prior to that, it had been known by its Aboriginal name Kaouenesgo. De la Salle was a key figure in opening up the Lake Ontario region for trade. He set up Fort Frontenac at what is now Kingston, to capitalize on the fur trade and included Amherst Island in his seigniory as a seat of control of water access to the Bay of Quinte.

In 1792, Amherst Island was designated as part of the historic County of Ontario. It consisted of the islands of the St. Lawrence River, and existed until 1800 when the county was dissolved and the islands attached to their respective counties on the north shore of Lake Ontario (Herrington 1913). The islands were not initially included in the UEL land grants, and were to remain in the hands of First Nations, but when it was noted that the major ones, including Amherst, were essentially the size of townships, they were reallocated to European settlement (Burleigh 1980).

In 1796, the western half of the island was granted to Sir John Johnson, a Loyalist Brigadier General and leader of the King's Royal Regiment of New York, with the eastern half being granted to him at a later date. Johnson, an American-born aristocrat, was forced to abandon a



STAGE 2 ARCHAEOLOGICAL ASSESSMENT: AMHERST ISLAND WIND ENERGY PROJECT, COLLECTOR LINE MODIFICATION

Project Context
December 1, 2014

sizable estate when he fled to Canada with his followers and tenants. After the war he was appointed by Governor Frederick Haldimand to supervise the settling along the St. Lawrence and Bay of Quinte. He was regarded by the Loyalist settlers in the region as their leader and was a front runner for first Governor of Upper Canada which he lost to John Graves Simcoe. Johnson was also appointed Inspector of Indian Affairs and championed their causes, even putting stop to certain proposed practices by the British government when he felt that they were detrimental to Native interests (Earle 2000). Johnson never settled on the island but instead left his son to act as his agent. Johnson also gave 500 acres of island land to John Stuart, the former chaplain of the King's Royal Regiment of New York, himself a Loyalist and important clergyman and educator who settled in Kingston in 1785 (Millman 2000). The island as an entire holding subsequently changed hands a number of times, including one memorable account whereby the sister of Johnson, a Maria Bowes, lost it in a game of cards to the Earl of Mountcashel, whose later financial troubles forced its seizure by the Sherriff in 1857 (Burleigh 1980).

By 1803, the northern shore of the island had begun to be settled and, over the next few decades, the population steadily climbed until by the early 1840s there were over 2000 inhabitants. As a popular stop over and harbour for boats travelling Lake Ontario between Kingston and parts west the island flourished but, like many marine settlements, with the advent of rail and road travel, floundered as its importance waned.

Meacham's 1878 map (Figure 3) shows in greater detail the further development of the island, with at least four churches of different denominations, including one Catholic church established to accommodate the large wave of Irish immigration to the island mid-century (Burleigh 1980). Two cemeteries are depicted at either end of the north shore of the island and there were three schools, including one serving the southern shore. Also evident are the shipping docks and a Post Office associated with the hamlet of Emerald, as well as a store and blacksmiths in both Emerald and Stella. There is also a note regarding a sulphur spring on the eastern outskirts of Emerald. The map shows that Lot 13, South Shore Concession, the current study area, was settled by Charles Girvin.

1.2.3 Recent Reports

The only archaeological reports that discusses the Project Area or land within 50 metres of it is related to the current project: the Stage 1 archaeological assessment report, entitled *Amherst Island Wind Energy Project, Stage 1 Archaeological Assessment, Various lots, South Shore Concession, North Shore Concession, Concession 1-3, Amherst island; and Lot 19, Concession 1; part of Lots 16-26, Concession 1; part of Lots 16-27, Broken Front, Township of Ernestown, Loyalist County, ON* (Stantec 2012), and the Stage 2 archaeological assessment report, entitled *Amherst Island Wind Energy Project, Stage 2 Archaeological Assessment, Various lots, South Shore Concession, North Shore Concession, Concession 1-3, Amherst Island; and Lot 19, Concession 1; part of Lots 16-26, Concession 1; part of Lots 16-27, Broken Front, Township of Ernestown, Loyalist County, ON* (Stantec 2013).



STAGE 2 ARCHAEOLOGICAL ASSESSMENT: AMHERST ISLAND WIND ENERGY PROJECT, COLLECTOR LINE MODIFICATION

Project Context
December 1, 2014

1.3 ARCHAEOLOGICAL CONTEXT

1.3.1 The Natural Environment

The study area is located in the Napanee Plain physiographic region, encompassing a geographic area of approximately 700 square miles around the Town of Napanee. The Napanee Plain is characterized by a flat to undulating plain of Limestone with Clay deposits to the south and a small amount of long, thin Drumlins (Chapman and Putnam 1984).

The soils of the study area consist of Lansdowne Clay, a calcareous, stone-free clay with imperfect drainage (Gillespie *et al.* 1963).

The major topographic feature of the area is Lake Ontario, which is approximately 15 metres to the south of the study area.

1.3.2 Pre-contact Aboriginal Resources

Overall, archaeological research in many parts of Eastern Ontario has been fairly limited, at least compared to adjoining areas in Southern Ontario and northern New York State, resulting in only a limited understanding of the cultural processes that occurred in this part of the province. The following summary of the prehistoric occupation of Eastern Ontario (see Table 1 for chronological chart) is based on syntheses in Archaeologix (2008), Ellis and Ferris (1990), Jacques Whitford (2008), Pilon (1999) and Wright (1995).

Identifiable human occupation of Ontario begins just after the end of the Wisconsin Glacial period. The first human settlement can be traced back 11,000 years, when this area was settled by Native groups that had been living to the south of the emerging Great Lakes. This initial occupation is referred to as the "Palaeo-Indian" archaeological culture.

Table 1: Southern Ontario Prehistoric Cultural Chronology, Years Before Present (BP)

Archaeological Period	Time	Characteristics
Early Paleo-Indian	11,000–10,400 BP	caribou and extinct Pleistocene mammal hunters, small camps
Late Paleo-Indian	10,400–10,000 BP	smaller but more numerous sites
Early Archaic	10,000–8,000 BP	slow population growth, emergence of woodworking industry, development of specialised tools
Middle Archaic	8,000–4,500 BP	environment similar to present, fishing becomes important component of subsistence, wide trade networks for exotic goods
Late Archaic	4,500–3,100 BP	increasing site size, large chipped lithic tools, introduction of bow hunting



STAGE 2 ARCHAEOLOGICAL ASSESSMENT: AMHERST ISLAND WIND ENERGY PROJECT, COLLECTOR LINE MODIFICATION

Project Context
December 1, 2014

Terminal Archaic	3,100-2,950 BP	emergence of true cemeteries with inclusion of exotic trade goods
Early Woodland	2,950-2,400 BP	introduction of pottery, continuation of Terminal Archaic settlement and subsistence patterns
Middle Woodland	2,400-1,400 BP	increased sedentism, larger settlements in spring and summer, dispersed smaller settlement in fall and winter, some elaborate mortuary ceremonialism
Transitional Woodland	1,400-1,100 BP	incipient agriculture in some locations, seasonal hunting & gathering
Late Woodland (Early Iroquoian)	1,100-700 BP	limited agriculture, development of small village settlement, small communal longhouses
Late Woodland (Middle Iroquoian)	700-600 BP	shift to agriculture as major component of subsistence, larger villages with large longhouses, increasing political complexity
Late Woodland (Late Iroquoian)	600- 350 BP	very large villages with smaller houses, politically allied regional populations, increasing trading network

Early Palaeo-Indian (EPI) (11,000-10,400 before present BP) settlement patterns suggest that small groups, or "bands", followed a pattern of seasonal mobility extending over large territories. Many (although by no means all) of the EPI sites were located on former beach ridges associated with Lake Algonquin, the post-glacial lake occupying the Lake Huron/Georgian Bay basin, and research/evidence indicates that the vegetative cover of these areas would have consisted of open spruce parkland, given the cool climatic conditions. Sites tend to be located on well-drained loamy soils, and on elevations in the landscape, such as knolls. The fact that assemblages of artifacts recovered from EPI sites are composed exclusively of stone skews our understanding of the general patterns of resource extraction and use. However, the taking of large game, such as caribou, mastodon and mammoth, appears to be of central importance to the sustenance of these early inhabitants. Moreover, EPI site location often appears to be located in areas which would have intersected with migratory caribou herds. In the Ottawa Valley it appears that the palaeo-environment had not recovered sufficiently from the former glaciations to have allowed an EPI occupation. There is, however, some evidence of EPI incursion to the Rideau Lakes area.

The Late Palaeo-Indian (LPI) period (10,400-10,000 BP) is poorly understood compared to the EPI, the result of less research focus than the EPI. As the climate warmed the spruce parkland was gradually replaced and the vegetation of Southern Ontario began to be dominated by closed coniferous forests. As a result many of the large game species that had been hunted in the EPI period either moved north with the more open vegetation, or became locally extinct. Like the EPI, LPI peoples covered large territories as they moved around to exploit different resources. Environmental conditions in Eastern Ontario and the Ottawa Valley were sufficient to allow for a Late Palaeo-Indian occupation, although the evidence of such is still very limited.



STAGE 2 ARCHAEOLOGICAL ASSESSMENT: AMHERST ISLAND WIND ENERGY PROJECT, COLLECTOR LINE MODIFICATION

Project Context
December 1, 2014

The transition from the Palaeo-Indian period to the Archaic archaeological culture of Ontario prehistory is evidenced in the archaeological record by the development of new tool technologies, the result of using an increasing number of resources as compared to peoples from earlier archaeological cultures, and developing a broader based series of tools to more intensively exploit those resources. During the Early Archaic period (10,000-8,000 BP), the jack and red pine forests that characterized the LPI environment were replaced by forests dominated by white pine with some associated deciduous elements. Early Archaic projectile points differ from Palaeo-Indian forms most notably by the presence of side and corner notching on their bases. A ground stone tool industry, including celts and axes, also emerges, indicating that woodworking was an important component of the technological development of Archaic peoples. Although there may have been some reduction in the degree of seasonal mobility, it is still likely that population density during the Early Archaic was low, and band territories large.

The development of more diversified tool technology continued into the Middle Archaic period (8,000-4,500 BP). The presence of grooved stone net-sinkers suggests an increase in the importance of fishing in subsistence activities. Another new tool, the bannerstone, also made its first appearance during this period. Bannerstones are ground stone weights that served as counterbalance for "atlatls" or spear-throwers, again indicating the emergence of a new technology. The increased reliance on local, often poor quality chert resources for chipped stone tools suggests that in the Middle Archaic groups inhabited smaller territories lacking high quality raw materials. In these instances lower quality materials which had been glacially deposited in local tills and river gravels were used.

This reduction in territory size appears to have been the result of gradual region-wide population growth, which forced a reorganization of subsistence patterns, as a larger population had to be supported from the resources of a smaller area. Stone tools designed specifically for the preparation of wild plant foods suggest that subsistence catchment was being widened and new resources being more intensively exploited. A major development of the later part of the Middle Archaic period was the initiation of long distance trade. In particular, native copper tools manufactured from sources near Lake Superior were being widely traded.

During the later part of the Middle Archaic (5,500-4,500 BP) a distinctive occupation, or tradition, known as the Laurentian Archaic, appears in south-eastern Ontario, western Quebec, northern New York and Vermont. Laurentian Archaic sites are found only within the transitional zone between the deciduous forests to the south and coniferous forests to the north known as the Canadian Biotic Province and are identifiable through the association of certain diagnostic tool types, including ground slate semi-lunar knives (or "ulus"), plummets for use in fishing, ground slate points and knives, and ground stone gouges, adzes and grooved axes. It is thought that there was less reliance on plant foods and a greater reliance on hunting and fishing in this region than for Archaic peoples in southern and south-western Ontario. Laurentian Archaic sites have been found in the middle Ottawa River valley, along the Petawawa and Trent River watersheds and at Brockville.



STAGE 2 ARCHAEOLOGICAL ASSESSMENT: AMHERST ISLAND WIND ENERGY PROJECT, COLLECTOR LINE MODIFICATION

Project Context
December 1, 2014

The trend towards decreased territory size and a broadening subsistence base continued during the Late Archaic (4,500-2,900 BP). Late Archaic sites are far more numerous than either Early or Middle Archaic sites. It appears that the increase in numbers of sites at least partly represents an increase in population. However, around 4,500 BP water levels in the Great Lakes began to rise, taking their modern form. It is likely that the relative paucity of earlier Archaic sites is due to their being inundated under the rising lake levels.

The appearance of the first true cemeteries occurs during the Late Archaic. Prior to this period, individuals were interred close to the location where they died. However, with the advent of the Late Archaic and local cemeteries individuals who died at a distance from the cemetery would be returned for final burial at the group cemetery often resulting in disarticulated skeletons, occasionally missing minor bone elements (e.g. finger bones). The emergence of local group cemeteries has been interpreted as being a response to both increased population densities and competition between local groups for access to resources, in that cemeteries would have provided symbolic claims over a local territory and its resources.

Increased territoriality and more limited movement are also consistent with the development of distinct local styles of projectile points. The trade networks which began in the Middle Archaic expand during this period, and begin to include marine shell artifacts (such as beads and gorgets) from as far away as the Mid-Atlantic coast. These marine shell artifacts and native copper implements show up as grave goods, indicating the value of the items. Other artifacts such as polished stone pipes and slate gorgets also appear on Late Archaic sites. One of the more unusual of the Late Archaic artifacts is the "birdstone", a small, bird-like effigy usually manufactured from green banded slate.

The Early Woodland period (2,900-2,200 BP) is distinguished from the Late Archaic period primarily by the addition of ceramic technology. While the introduction of pottery provides a useful demarcation point for archaeologists, it may have made less difference in the lives of the Early Woodland peoples. The first pots were very crudely constructed, thick walled, and friable. It has been suggested that they were used in the processing of nut oils by boiling crushed nut fragments in water and skimming off the oil. These vessels were not easily portable, and individual pots must not have enjoyed a long use life. There have also been numerous Early Woodland sites located at which no pottery was found, suggesting that these poorly constructed, undecorated vessels had yet to assume a central position in the day-to-day lives of Early Woodland peoples.

Other than the introduction of this rather limited ceramic technology, the life-ways of Early Woodland peoples show a great deal of continuity with the preceding Late Archaic period. For instance, birdstones continue to be manufactured, although the Early Woodland varieties have "pop-eyes" which protrude from the sides of their heads. Likewise, the thin, well-made projectile points which were produced during the terminal part of the Archaic period continue in use. However, the Early Woodland variants were side-notched rather than corner-notched, giving them a slightly altered and distinctive appearance. The trade networks which were established



STAGE 2 ARCHAEOLOGICAL ASSESSMENT: AMHERST ISLAND WIND ENERGY PROJECT, COLLECTOR LINE MODIFICATION

Project Context
December 1, 2014

in the Middle and Late Archaic also continued to function, although there does not appear to have been as much traffic in marine shell during the Early Woodland period. These trade items were included in increasingly sophisticated burial ceremonies, including construction of burial mounds.

In terms of settlement and subsistence patterns, the Middle Woodland (2,200 B.C.-1,100 BP) provides a major point of departure from the Archaic and Early Woodland periods. While Middle Woodland peoples still relied on hunting and gathering to meet their subsistence requirements, fish were becoming an even more important part of the diet. Middle Woodland vessels are often heavily decorated with hastily impressed designs covering the entire exterior surface and upper portion of the vessel interior. Consequently, even very small fragments of Middle Woodland vessels are easily identifiable.

It is also at the beginning of the Middle Woodland period that rich, densely occupied sites appear along the margins of major rivers and lakes. While these areas had been utilized by earlier peoples, Middle Woodland sites are significantly different in that the same location was occupied off and on for as long as several hundred years. Because this is the case, rich deposits of artifacts often accumulated. Unlike earlier seasonally utilized locations, these Middle Woodland sites appear to have functioned as base camps, occupied off and on throughout the course of the year. There are also numerous small upland Middle Woodland sites, many of which can be interpreted as special purpose camps from which localized resource patches were exploited. This shift towards a greater degree of sedentism continues the trend witnessed from the Middle Archaic, and provides a prelude to the developments that follow during the Late Woodland period.

There are three complexes of Middle Woodland culture in Ontario. The complex specific to eastern Ontario is known as "Princess Point" most notably represented by ceramics decorated with a stamped zigzag pattern applied at various angles to the exterior of the vessel, known as "pseudo scallop shell". Another common decorative style is the dentate stamp, a comb-like tool creating square impressions.

The relatively brief period of the Transitional Woodland period is marked by the acquisition of cultivar plants species, such as maize and squash, from communities living south of the Great Lakes. The appearance of these plants began a transition to food production, which consequently led to a much reduced need to acquire naturally occurring food resources. Sites were thus occupied for longer periods and by larger populations. Transitional Woodland sites have not been undiscovered in eastern Ontario.

The Late Woodland period in southern Ontario is associated with societies referred to as the Ontario Iroquois Tradition. This period is often divided into three temporal components; Early, Middle and Late Iroquoian (see Table 3.1). In eastern Ontario, especially in the Ottawa River Valley, there is considerable overlap of people continuing to practice a hunting and gathering economy and those using limited horticulture as a supplement to gathered plants. For the most



STAGE 2 ARCHAEOLOGICAL ASSESSMENT: AMHERST ISLAND WIND ENERGY PROJECT, COLLECTOR LINE MODIFICATION

Project Context
December 1, 2014

part, however, classic Late Woodland sites in eastern Ontario are limited to an area at the east end of Lake Ontario and along the St. Lawrence River valley. Middle Iroquoian sites have not been identified east of Kingston.

During the Late Iroquoian period a distinctive material culture emerges at the east end of Lake Ontario and along the St. Lawrence River up to Québec City, known as the St. Lawrence Iroquois (SLI). SLI sites are characterized by large semi-permanent villages and associated satellite settlements. The inhabitants of these villages and satellites practiced horticulture of staple crops which made up the bulk of their diet. Other food resources were hunted, fished and gathered. SLI village sites can be extensive, up to 10 acres or more in size and composed of a number of longhouse structures. Special purpose satellite settlements, such as hunting and fishing camps, are smaller in area and in the number and size of structures within the settlement. The inhabitants of these villages and satellites practiced horticulture of staple crops which made up the bulk of the diet. Other food resources were hunted, fished and gathered (cf. Pendergast 1974; Jaimeson 1990; Stewart 1992). Late Woodland village sites can be extensive, up to 10 acres or more in size and composed of a number of longhouse structures. Satellite settlements are smaller in extent and in the number and size of structures within the settlement. SLI sites are located in territory on either side of the St. Lawrence River, from the east end of Lake Ontario to the vicinity of Quebec City (Jamieson 1990).

Overall conditions in the study area are considered very favourable for prehistoric occupation, including access to a wide variety of econiches for the harvesting of plant, fish and animal resources, and access to major transportation routes along the Lake Ontario shoreline.

1.3.3 Previously Known Archaeological Sites and Surveys

In order to compile an inventory of archaeological resources, the registered archaeological site records kept by the MTCS were consulted. In Ontario, information concerning archaeological sites stored in the archaeological sites database (ASDB) maintained by the MTCS. This database contains archaeological sites registered according to the Borden system. Under the Borden system, Canada is divided into grid blocks based on latitude and longitude. A Borden Block is approximately 13 kilometres east to west and approximately 18.5 kilometres north to south. Each Borden Block is referenced by a four-letter designator and sites within a block are numbered sequentially as they are found. The Project Area under review is located within Borden Block BaGd.

Information concerning specific site locations is protected by provincial policy, and is not fully subject to the *Freedom of Information and Protection of Privacy Act*. The release of such information in the past has led to looting or various forms of illegally conducted site destruction. Confidentiality extends to all media capable of conveying location, including maps, drawings, or textual descriptions of a site location. The MTCS will provide information concerning site location to the party or an agent of the party holding title to a property, or to a licensed archaeologist with relevant cultural resource management interests.



STAGE 2 ARCHAEOLOGICAL ASSESSMENT: AMHERST ISLAND WIND ENERGY PROJECT, COLLECTOR LINE MODIFICATION

Project Context
December 1, 2014

The Stage 1 report indicated that much of the study area had high potential for the presence for archaeological resources and a Stage 2 archaeological assessment would need to be completed prior to construction activities (Stantec 2012). During the Stage 2 assessment conducted by Stantec (Stnatec 2013), seven (7) archaeological sites wre identified, including:, five (5) Euro-Canadian sites; one (1) pre-contact Aboriginal site; and one (1) indeterminate site. None of these sites are located within 1 kilometre of the present study area.

1.3.4 Existing Conditions

The study area is located on a manicured lawn and encompasses an area approximately 90 metres north-south by 15 metres east-west (Figure 4).

STAGE 2 ARCHAEOLOGICAL ASSESSMENT: AMHERST ISLAND WIND ENERGY PROJECT, COLLECTOR LINE MODIFICATION

Field Methods
December 1, 2014

2.0 FIELD METHODS

Prior to the property survey all available archaeological reports were reviewed. The Stage 2 assessment of the Amherst Island Wind Energy Project, Collector Line Modification study area was conducted on October 24, 2014 under archaeological consulting license P415 issued to Patrick Hoskins, MA, of Stantec by the MTCS. The study area comprises an area approximately 90 metres north-south by 15 metres east-west in size of manicured lawn, located on part of Lot 13, South Shore Concession, Amherst Island, County of Lennox and Addington, Ontario.

During the Stage 2 survey, assessment conditions were excellent and at no time were the field, weather, or lighting conditions detrimental to the recovery of archaeological material (Table 22). Photos 1 to 2 in Section 8.1 of this report confirm that field conditions met the requirements for a Stage 2 archaeological assessment using a test pit excavation methodology, as per Section 2.1.2, Standard 1D of the MTCS' 2011 *Standards and Guidelines for Consultant Archaeologists* (Section 7.8.6 Standard 1a; Government of Ontario 2011). Figure 5 provides an illustration of the Stage 2 assessment methods, as well as photograph locations and directions.

Table 2: Field and Weather Conditions

Date	Activity	Weather	Field Conditions
October 24, 2014	Stage 2 test pit survey	Sunny, warm	85-95% visibility

The study area was subjected to a Stage 2 test pit survey at a five metre interval (Photos 1-2) in accordance with Section 2.1.2 of the MTCS's 2011 *Standards and Guidelines for Consultant Archaeologists* (Government of Ontario 2011). Each test pit was approximately 30 centimetres in diameter and excavated five centimetres into sterile subsoil (Photos 3-4). The soils were then examined for stratigraphy, cultural features, or evidence of fill. All soil was screened through six millimeter mesh hardware cloth to facilitate the recovery of small artifacts and then used to backfill the pit. No test pit excavation occurred within the disturbed roadway or ditch at the south end of the study area.

STAGE 2 ARCHAEOLOGICAL ASSESSMENT: AMHERST ISLAND WIND ENERGY PROJECT, COLLECTOR LINE MODIFICATION

Record of Finds
December 1, 2014

3.0 RECORD OF FINDS

The Stage 2 archaeological assessment was conducted employing the methods described in Section 2.0. An inventory of the documentary record generated by fieldwork is provided in Table 3 below.

Table 3: Inventory of the Documentary Record

Document Type	Current Location of Document Type	Additional Comments
1 pages of field notes	Stantec office in Ottawa	In original field book and scanned into project folder
1 map provided by client	Stantec office in Ottawa	Hard and digital copies in project file
6 Digital Photographs	Stantec office in Ottawa	Stored digitally in project file

No material culture remains were identified or collected during the Stage 2 assessment of the proposed Amherst Island Wind Energy Project, Collector Line Modification.

STAGE 2 ARCHAEOLOGICAL ASSESSMENT: AMHERST ISLAND WIND ENERGY PROJECT, COLLECTOR LINE MODIFICATION

Analysis and Conclusions
December 1, 2014

4.0 ANALYSIS AND CONCLUSIONS

Stantec was retained by Windlectric Inc. to conduct a Stage 2 archaeological assessment for the proposed Amherst Island Wind Energy Project, Collector Line Modification. The study area was subjected to a Stage 2 test pit survey. No archaeological resources were identified during the Stage 2 assessment of the study area.



STAGE 2 ARCHAEOLOGICAL ASSESSMENT: AMHERST ISLAND WIND ENERGY PROJECT, COLLECTOR LINE MODIFICATION

Recommendations
December 1, 2014

5.0 RECOMMENDATIONS

The Stage 2 archaeological assessment of the proposed Amherst Island Wind Energy Project, Collector Line Modification resulted in the recovery of no archaeological resources. **It is recommended that no further archaeological assessment of the study area is required.**

The *Ministry of Tourism, Culture and Sport* is asked to accept this report into the Ontario Public Register of Archaeological Reports.

STAGE 2 ARCHAEOLOGICAL ASSESSMENT: AMHERST ISLAND WIND ENERGY PROJECT, COLLECTOR LINE MODIFICATION

Advice on Compliance with Legislation
December 1, 2014

6.0 ADVICE ON COMPLIANCE WITH LEGISLATION

This report is submitted to the Minister of Tourism, Culture and Sport as a condition of licensing in accordance with Part VI of the *Ontario Heritage Act*, R.S.O. 1990, c 0.18. The report is reviewed to ensure that it complies with the standards and guidelines that are issued by the Minister, and that the archaeological fieldwork and report recommendations ensure the conservation, protection and preservation of the cultural heritage of Ontario. When all matters relating to archaeological sites within the project area of a development proposal have been addressed to the satisfaction of the Ministry of Tourism, Culture and Sport, a letter will be issued by the ministry stating that there are no further concerns with regard to alterations to archaeological sites by the proposed development.

It is an offence under Sections 48 and 69 of the *Ontario Heritage Act* for any party other than a licensed archaeologist to make any alteration to a known archaeological site or to remove any artifact or other physical evidence of past human use or activity from the site, until such time as a licensed archaeologist has completed fieldwork on the site, submitted a report to the Minister stating that the site has no further cultural heritage value or interest, and the report has been filed in the Ontario Public Register of Archaeology Reports referred to in Section 65.1 of the *Ontario Heritage Act*.

Should previously undocumented archaeological resources be discovered, they may be a new archaeological site and therefore subject to Section 48(1) of the *Ontario Heritage Act*. The proponent or person discovering the archaeological resources must cease alteration of the site immediately and engage a licensed consultant archaeologist to carry out archaeological fieldwork, in compliance with Section 48(1) of the *Ontario Heritage Act*.

The *Cemeteries Act*, R.S.O. 1990 c. C.4 and the *Funeral, Burial and Cremation Services Act*, 2002, S.O. 2002, c.33 (when proclaimed in force) require that any person discovering human remains must notify the police or coroner and the Registrar of Cemeteries at the Ontario Ministry of Consumer Services.

Archaeological sites recommended for further archaeological fieldwork or protection remain subject to Section 48(1) of the *Ontario Heritage Act* and may not be altered, or have artifacts removed from them, except by a person holding an archaeological license.

STAGE 2 ARCHAEOLOGICAL ASSESSMENT: AMHERST ISLAND WIND ENERGY PROJECT, COLLECTOR LINE MODIFICATION

Bibliography and Sources
December 1, 2014

7.0 BIBLIOGRAPHY AND SOURCES

- Archaeologix, 2008. *Archaeological Assessment (Stage 1) Shell Proposed Refinery Project, St. Clair Township, Lambton County, Ontario*. Report prepared for Jacques Whitford Limited, Markham, Ontario. (PIF # P084-109-2007).
- Burleigh, H.C. 1980. *Tales of Amherst Island*. Kingston: Brown & Martin Limited.
- Chapman, L.J. and D.F. Putnam. 1984. *The Physiography of Southern Ontario*. Third Edition. Ontario Geological Survey. Special Volume 2.
- Earle, Thomas. 2000. *Dictionary of Canadian Biography Online: Sir John Johnson*. University of Toronto/Université de Laval. www.biographi.ca/009004-119.01-e.php?&id_nbr=2937.
- Ellis, Chris J. and Neal Ferris (editors). 1990. *The Archaeology of Southern Ontario to A.D. 1650*. Occasional Publication of the London Chapter, Ontario Archaeological Society, Number 5.
- Gillespie, J.E., R.E. Wicklund and B.C. Matthews. 1963. *The Soil Survey of Lennox and Addington County*. Report No. 36 of the Ontario Soil Survey. Ottawa: Department of Agriculture.
- Government of Ontario. 1990. *Ontario Heritage Act, R.S.O. 1990, CHAPTER O.18*. Last amendment: 2009, c. 33, Sched. 11, s. 6. Electronic document: http://www.e-laws.gov.on.ca/html/statutes/english/elaws_statutes_90o18_e.htm. Last accessed July 7, 2014.
- Government of Ontario. 2011. *Standards and Guidelines for Consultant Archaeologists*. Toronto: Ministry of Tourism, Culture and Sport.
- Government of Ontario. n.d. *Archaeological Sites Database Files*. Toronto: Archaeology Programs Unit, Ministry of Tourism, Culture and Sport.
- Herrington, Walter S. 1913. *History of the County of Lennox and Addington*. Macmillan Publishing: Toronto.
- Herrington, Walter S. 1915. *Pioneer life among the loyalists in Upper Canada*. Macmillan Publishing: Toronto.
- Jacques Whitford, 2008. *Stage 1 Archaeological Impact Assessment - Interconnecting and Third Party Pipelines*. Report prepared for Shell Canada Products, Sarnia, ON. (PIF # P002-128-2007).



STAGE 2 ARCHAEOLOGICAL ASSESSMENT: AMHERST ISLAND WIND ENERGY PROJECT, COLLECTOR LINE MODIFICATION

Bibliography and Sources
December 1, 2014

- Jamieson, J. Bruce. 1990. The Archaeology of the St. Lawrence Iroquoians, in *The Archaeology of Southern Ontario to A.D. 1650*. Chris J. Ellis and Neal Ferris (eds.). Occasional Publication of the London Chapter, Ontario Archaeological Society, No. 5.
- Meacham, J.H. 1878. *Illustrated Historical Atlas of the Counties of Frontenac, Lennox and Addington, Ontario*. Toronto: J.H. Meacham & Co.
- Millman, T.R. 2000. *Dictionary of Canadian Biography Online: John Stuart*. University of Toronto/Université de Laval. www.biographi.ca/009004-119.01-e.php?&id_nbr=2677
- Morris, J.L. 1943. *Indians of Ontario*. 1964 reprint. Toronto: Department of Lands and Forests.
- Pendergast, James F. 1974. The Sugarbush Site: A Possible Iroquoian Maplesugar Camp. *Ontario Archaeology*, 23:31-61.
- Pilon, Jean-Luc (ed), 1999. *La préhistoire de l'Outaouais - Ottawa Valley Prehistory*. Institut d'histoire et de recherches sur l'Outaouais, Hull, Quebec.
- Stantec Consulting Ltd., 2012. *Stage 1 Archaeological Assessment, Various lots, South Shore Concession, North Shore Concession, Concessions 1-3, Amherst Island; Lot 19, Concession 1; part Lots 16-26, Concession 1; part Lots 16-27, Broken Front, Township of Ernestown, Loyalist County, ON*. Report on file with the Ministry of Tourism, Culture and Sport, Toronto, Ontario.
- Stantec Consulting Ltd., 2013. *Stage 2 Archaeological Assessment, Various lots, South Shore Concession, North Shore Concession, Concessions 1-3, Amherst Island; Lot 19, Concession 1; part Lots 16-26, Concession 1; part Lots 16-27, Broken Front, Township of Ernestown, Loyalist County, ON*. Report on file with the Ministry of Tourism, Culture and Sport, Toronto, Ontario.
- Stewart, Frances L. 1992. Faunal Findings from Three Longhouses of the McKeown Site (BeFv-1), A St. Lawrence Iroquoian Village. *Ontario Archaeology*, 54:17-36.
- Wright, J.V., 1995. *A History of the Native People of Canada Volume 1 (10,000 – 1,000 B.C.)*. Museum of Civilization, Mercury Series, Archaeology Paper 152. Gatineau, PQ: Canadian Museum of Civilization.

STAGE 2 ARCHAEOLOGICAL ASSESSMENT: AMHERST ISLAND WIND ENERGY PROJECT, COLLECTOR LINE MODIFICATION

Images
December 1, 2014

8.0 IMAGES

8.1 PHOTOS

Photo 1: Test Pit Survey at 5 Metre Intervals, facing northwest



Photo 2; Test Pit Survey at 5 Metre Intervals, facing west



STAGE 2 ARCHAEOLOGICAL ASSESSMENT: AMHERST ISLAND WIND ENERGY PROJECT, COLLECTOR LINE MODIFICATION

Images
December 1, 2014

Photo 3: View of Test Pit



Photo 4: View of Test Pit



STAGE 2 ARCHAEOLOGICAL ASSESSMENT: AMHERST ISLAND WIND ENERGY PROJECT, COLLECTOR LINE MODIFICATION

Maps
December 1, 2014

9.0 MAPS

All mapping with will follow on succeeding pages. Maps identifying exact site locations do not form part of this public report; they may be found in the Supplementary Documentation.





Legend

-  Project Study Area
-  Railway
-  Watercourse

Notes

1. Coordinate System: UTM NAD 83 - Zone 18 (N).
2. Base features produced under license with the Ontario Ministry of Natural Resources © Queen's Printer for Ontario, 2012.
3. Imagery Source: First Base Solutions ©, 2012. Imagery Date: 2008.



Stantec

November 2012
160960595

Client/Project	WINDLECTRIC INC. AMHERST ISLAND WIND ENERGY PROJECT
Figure No.	1
Title	Site Location

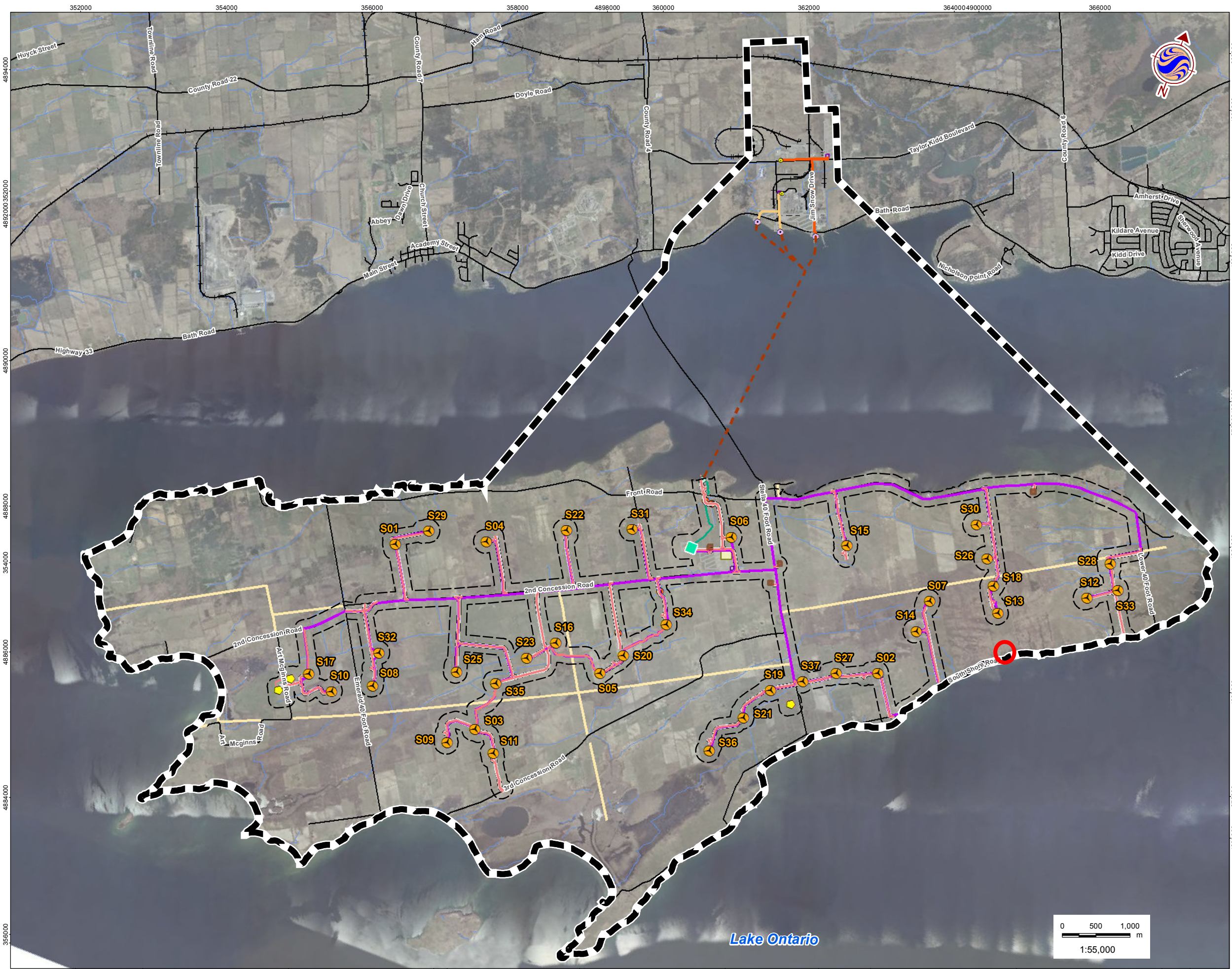

Legend

Project Components

- Project Study Area
- 120m Zone of Investigation
- Turbine
- Met Tower (Potential Location)
- Substation (Potential Location)
- Collector Lines
- Access Road
- Submarine Cable Path
- Laydown Area and Crane Pad
- Potential Culvert Location
- Point of Common Coupling
- Mainland Cable Vault (Potential Location)
- Island Cable Vault
- Turbine Blade Tips
- Constructible Area
- Mainland Dock (Potential Location)
- Island Dock
- Batch Plant (Potential Location)
- Site Office (Potential Location)
- Storage Shed
- Operation and Maintenance Building (Potential Location)

TransmissionLine

- Mainland Option 1
- Mainland Option 2
- Island Transmission Line

Land Use

- Central Staging Area
- Switching Station (Potential Location)

Existing Features

- Road
- Unopened Road Allowance
- Railway
- Watercourse
- Current Study Area

Notes

- Coordinate System: UTM NAD 83 - Zone 18 (N).
- Base features produced under license with the Ontario Ministry of Natural Resources © Queen's Printer for Ontario, 2012.
- Imagery Source: First Base Solutions ©, 2012. Imagery Date: 2008.



December 2012
160960595

Client/Project
**WINDLECTRIC INC.
AMHERST ISLAND WIND ENERGY PROJECT**

Figure No.
2

Title
Site Plan

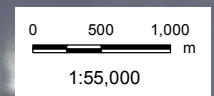



Legend

- Project Study Area
- 120m Zone of Investigation
- Project Components**
 - Turbine
 - Met Tower (Potential Location)
 - Substation (Potential Location)
 - Collector Lines
 - Access Road
 - Submarine Cable Path
 - Potential Culvert Location
 - Point of Common Coupling
 - Mainland Cable Vault (Potential Location)
 - Island Cable Vault
 - Turbine Blade Tips
 - Constructible Area
 - Mainland Dock (Potential Location)
 - Island Dock
 - Batch Plant (Potential Location)
 - Site Office (Potential Location)
 - Storage Shed
 - Operation and Maintenance Building (Potential Location)
- TransmissionLine**
 - Mainland Option 1
 - Mainland Option 2
 - Island Transmission Line
- MainlandComponents**
 - Central Staging Area
 - Switching Station (Potential Location)
- Existing Features**
 - Road
 - Unopened Road Allowance
 - Railway
 - Watercourse
- Current Study Area

Notes

- Coordinate System: UTM NAD 83 - Zone 18 (N).
- Base features produced under license with the Ontario Ministry of Natural Resources © Queen's Printer for Ontario, 2012.



November 2014
160960595

Client/Project
WINDLECTRIC INC.
AMHERST ISLAND WIND ENERGY PROJECT

Figure No.
3

Title
Meacham's 1878 Historic Mapping Overlaid by Project Components (Eastern Portion)

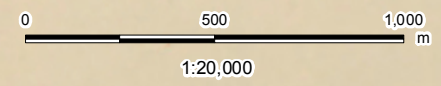



Legend

- Study Area
- 120m Zone of Investigation
- Project Components**
 - Turbine
 - Met Tower
 - Access Road
 - Collector Lines
 - Laydown Area and Crane Path
 - Submarine Cable Path
 - Dock Footprint
 - Laydown and Storage Area (Potential Location)
 - Operation and Maintenance Building (Potential Location)
 - Shed
 - Turbine Blade Tips
 - Substation (Potential Location)
 - Potential Culvert Location
 - Point of Common Coupling
- Transmission Lines**
 - Overhead - Option 1
 - Underground - Option 1
 - Overhead - Option 2
 - Underground - Option 2
- Land Use**
 - Laydown, Storage, Parking & Office
 - Optional Cable Landing
 - Proposed Rail and Unloading Crane Pad
 - Proposed Switching Station
- Existing Features**
 - Road
 - Unopened Road Allowance
 - Railway
 - Watercourse
 - Property Line
- Current Study Area

- ### Notes
- Coordinate System: UTM NAD 83 - Zone 18 (N).
 - Base features produced under license with the Ontario Ministry of Natural Resources © Queen's Printer for Ontario, 2012. Project layout S19 - revision 3.
 - Imagery Source: First Base Solutions ©, 2012. Imagery Date: 2008



October 2012
160960595

Client/Project
WINDLECTRIC INC.
AMHERST ISLAND WIND ENERGY PROJECT

Figure No. 4

Title **Location of Stage 2 AA Testing**





Legend

- Study Area
- 120m Zone of Investigation
- Photo Location
- Project Components**
- Turbine
- Met Tower
- Access Road
- Collector Lines
- Laydown Area and Crane Path
- Submarine Cable Path
- Dock Footprint
- Laydown and Storage Area (Potential Location)
- Operation and Maintenance Building (Potential Location)
- Shed
- Turbine Blade Tips
- Substation (Potential Location)
- Potential Culvert Location
- Point of Common Coupling
- Transmission Lines**
- Overhead - Option 1
- Underground - Option 1
- Overhead - Option 2
- Underground - Option 2
- Land Use**
- Laydown, Storage, Parking & Office
- Optional Cable Landing
- Proposed Rail and Unloading Crane Pad
- Proposed Switching Station
- Existing Features**
- Road
- Unopened Road Allowance
- Railway
- Watercourse
- Property Line
- Ploughed Areas**
- Ploughed for Pedestrian Survey
- Not Surveyed
- Test Pit Survey

Notes

1. Coordinate System: UTM NAD 83 - Zone 18 (N).
2. Base features produced under license with the Ontario Ministry of Natural Resources © Queen's Printer for Ontario, 2012. Project layout S19 - revision 3.
3. Imagery Source: First Base Solutions ©, 2012. Imagery Date: 2008



November 2014
160960595

Client/Project	WINDLECTRIC INC. AMHERST ISLAND WIND ENERGY PROJECT
Figure No.	5
Title	Location of Additional Stage 2 AA Testing Property R337



STAGE 2 ARCHAEOLOGICAL ASSESSMENT: AMHERST ISLAND WIND ENERGY PROJECT, COLLECTOR LINE MODIFICATION

Closure
December 1, 2014

10.0 CLOSURE

This report has been prepared for the sole benefit the Winlectric Inc. and may not be used by any third party without the express written consent of Stantec Consulting Ltd., and Winlectric Inc.. Any use which a third party makes of this report is the responsibility of such third party.

We trust this report meets your current requirements. Please do not hesitate to contact us should you require further information or have additional questions about any facet of this report.

Project Manager Review _____
(signature) 

Colin Varley, MA, RPA (P002)

Licensee Review _____
(signature) 

Patrick Hoskins, MA (P415)

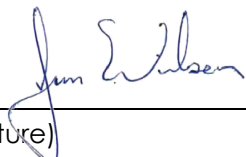
Senior Review _____
(signature) 

Jim Wilson, MA (P001)



Skillen, Kerrie

From: Sean Fairfield <Sean.Fairfield@algonquinpower.com>
Sent: Tuesday, January 06, 2015 2:38 PM
To: Campbell, Paige (MTCS)
Cc: Alex Tsopelas; Varley, Colin; Skillen, Kerrie
Subject: RE: Amherst Island Wind Energy

Hi Paige – thank you.

Regards,

Sean Fairfield | Algonquin Power Co. | Senior Manager - Project Planning
P: 905-465-4518 | C: 905-466-1360 | F: 905-465-4514
E: sean.fairfield@algonquinpower.com
354 Davis Road, Oakville, Ontario L6J 2X1

Safety, Make it Personal...

N O T I C E - This message is intended only for the use of the individual or entity to which it is addressed and may contain information which is privileged, confidential or proprietary. Internet communications cannot be guaranteed to be secure or error-free as information could be intercepted, corrupted, lost, arrive late or contain viruses. By communicating with us via e-mail, you accept such risks. When addressed to our clients, any information, drawings, opinions or advice (collectively, "information") contained in this e-mail is subject to the terms and conditions expressed in the governing agreements. Where no such agreement exists, the recipient shall neither rely upon nor disclose to others, such information without our written consent. Unless otherwise agreed, we do not assume any liability with respect to the accuracy or completeness of the information set out in this e-mail. If you have received this message in error, please notify us immediately by return e-mail and destroy and delete the message from your computer.

From: Campbell, Paige (MTCS) [<mailto:Paige.Campbell@ontario.ca>]
Sent: Tuesday, January 06, 2015 2:02 PM
To: Sean Fairfield
Subject: Amherst Island Wind Energy

Sean,

I have reviewed and accepted the Stage 2 collector line modification report, for which no sites were found and no further work is recommended. The other modifications to the project involve reduction of project areas, so the existing Stage 2 report which covered the full extent of the original project is still valid and no additional Stage 2 work is required on the remainder of the project.

Seven archaeological sites were identified during the Stage 2 work and recommended for Stage 3. From my conversations with you and the archaeologists at Stantec I understand that all these sites will still undergo Stage 3 assessment in the upcoming field season(s), so the ministry is satisfied that all matters of archaeological concern for this project are being dealt with in a satisfactory manner and we have no additional concerns or comments at this time.

Paige Campbell
Archaeology Review Officer
Archaeology Program Unit

Ministry of Tourism, Culture and Sport
435 S. James Street, Suite 334
Thunder Bay, ON P7E 6S7
807-475-1628



Stantec Consulting Ltd.
49 Frederick Street, Kitchener ON N2H 6M7

December 1, 2014
File: 160960595

Attention: Laura Hatcher, MCIP, RPP, Team Lead: Heritage Land Use Planning

Culture Services Unit
Programs and Services Branch
Ministry of Tourism, Culture and Sport
401 Bay Street Suite
1700 Toronto ON M7A 0A7

Dear Ms. Hatcher,

Reference: Amherst Island Wind Energy Project Heritage Assessment – Project Layout Modifications

Algonquin Power (on behalf of Windlectric Inc.) is developing the Amherst Island Wind Energy Project (the Project), a proposed 75MW wind energy project on Amherst Island, located within Loyalist Township in the County of Lennox and Addington in eastern Ontario. As discussed with Ministry of Tourism, Culture and Sport (MTCS) on Tuesday, November 4, 2014, Algonquin Power is considering three modifications to the REA application for the Project.

This letter is submitted as an addendum to the Project Renewable Energy Approval Application – *Heritage Assessment* that was submitted to the MTCS in April 2013 and for which a letter of satisfaction was received on April 17, 2013.

The purpose of this letter is to provide the MTCS with an understanding of modifications that have been made to the location of the Project (details are listed below) since the *Heritage Assessment* was confirmed by the MTCS, and to provide an assessment of the proposed modifications in order to identify any additional potential effects, mitigation measures, or monitoring requirements that were not included in the *Heritage Assessment*. For the purposes of this summary, only additional infrastructure was assessed.

PROJECT DESCRIPTION

The basic components of the proposed Project include up to 36 Siemens wind turbines. The final layout will result in a total installed nameplate capacity of approximately 56 - 75 MW. The number of wind turbines will be dependent upon final selection of the model of the wind turbine most appropriate to the proposed Project.

At the time of the 2013 *Heritage Assessment*, the turbine model proposed utilized 36 turbine pad locations that have been subject to the assessment required under REA. The layout in the original REA application included 34 Siemens SWT-2.3-113 2300 kW and two (2) Siemens SWT-2.3-113 2221 kW model wind turbines.

Design with community in mind



December 1, 2014

Laura Hatcher, MCIP, RPP, Team Lead: Heritage Land Use Planning

Page 2 of 12

Reference: Amherst Island Wind Energy Project Heritage Assessment – Project Layout Modifications

The proposed Project will also include a 34.5 kilovolt (kV) underground and/or overhead electrical power line collector system, fibre optic data lines from each turbine and/or wireless technology for the communication of data, a transmission line, truck turnaround areas, a submarine cable, an operations and maintenance building, permanent dock, a substation, a switching station, an un-serviced storage shed, one connection point to the existing electrical system, cable vault areas, meteorological tower(s) (met tower(s)), access road(s) to the met tower site(s), and turbine access roads with culvert installations, as required, at associated watercourse crossings. It is understood that the collector system, including the collector and transmission lines, will be positioned below ground.

Temporary components during construction may include staging areas for the turbines, access roads, met tower(s), collector lines and transmission line as well as crane paths, a temporary dock, site office(s), batch plant, central staging areas, and associated watercourse crossings. The electrical power line collector system would transport the electricity generated from each turbine to the substation, along the submarine cable to the mainland and then to a switching station located near to an existing Hydro One Networks Inc. (HONI) 115 kV transmission line.

HERITAGE CONTEXT

Stantec was retained by Algonquin Power Co. on behalf of the Proponent to undertake the cultural heritage and protected properties assessments for the Project as required by *Ontario Regulation 359/09*. Both Reports received written comments expressing satisfaction from the MTCS in April, 2013. Representatives from Algonquin Power Co., Stantec, and the MTCS met via tele-conference to discuss proposed modifications on November 4, 2014. It was determined during that time that, as is the standard process for filing modifications following receipt of a letter of satisfaction, Stantec would prepare a letter summarizing the proposed changes and implications, if any, on cultural heritage resources.

PROPOSED MODIFICATION DESCRIPTION

There are three modifications which have been proposed following the completion of the *Heritage Assessment* (see Figure 1). These are: (1) a change in turbine model and associated reduction in the number of turbines, (2) a change in collection system routing to avoid the Village of Stella and (3) changes to the road and collection system to avoid some activities on 2nd Concession.

Further detail is provided below regarding the proposed modifications.

1. Reducing the number of Wind Turbines by changing Turbine Model (Siemens 2.942 MW and 2.772 MW)



December 1, 2014

Laura Hatcher, MCIP, RPP, Team Lead: Heritage Land Use Planning

Page 3 of 12

Reference: Amherst Island Wind Energy Project Heritage Assessment – Project Layout Modifications

This modification involves changing the Project's turbines from a combination of Siemens 2.3 MW and 2.221 MW to a combination of Siemens 2.942 MW and 2.772 MW, and thereby reducing the number of turbines from 36 to 27. The new turbines would be physically identical, specifically with a hub height of 99.5 m and rotor diameter of 113 m. The modification will decrease the Project Location size by reducing the number of turbine sites from 36 to 27. All of these 27 turbine sites are in previously studied and proposed locations.

The project modification has been discussed with the Ministry of the Environment and Climate Change (MOECC). The MOECC has verified this project modification is a Technical Change as pursuant to the classification system outlined in the Ministry of the Environment's *Technical Guide to Renewable Energy Approvals* (October, 2013). Given the nature of this technical update, the *Heritage Assessment* does not require any additional assessment. As such, the update is being provided for MTCS's information.

2. Collection System Route Change 1 – Avoiding the Village of Stella

This proposed modification would involve rerouting the collection system to avoid the Village of Stella. In doing so, this modification would remove a significant portion of the existing collection system from S30 entrance along Front Road, including by removing approximately 4 km of road allowance trenching (including through Stella). The modification would also require a new collection corridor from S13 to South Shore Rd. and west to S14 entrance, which would consist of approximately 1 km in road allowance and 700 m of in pasture field. The modification will decrease the Project Location size by resulting in a net reduction of approximately 2 km of collection system trenching.

The project modification has been discussed with the Ministry of the Environment and Climate Change (MOECC). The MOECC has verified this project modification is a Project Design Change as pursuant to the classification system outlined in the Ministry of the Environment's *Technical Guide to Renewable Energy Approvals* (October, 2013). Additional assessment to determine the presence of potential heritage resources is necessary along South Shore Road in between Turbines S13 and S14. This was undertaken as described in the text below.

3. Collection System Route Change 2 – Reducing Impacts on 2nd Concession

This modification would involve the addition of an underground collector line along a previously approved access road between T16/T23 and T35. The collector line has been incorporated into the design of the access road between T16/23 and T35. The modification will decrease the Project Location size by eliminating the need to install a second collection circuit trench on approximately 3 km of 2nd Concession.



Reference: Amherst Island Wind Energy Project Heritage Assessment – Project Layout Modifications

The project modification has been discussed with the Ministry of the Environment and Climate Change (MOECC). The MOECC has verified this project modification is a Technical Change as pursuant to the classification system outlined in the Ministry of the Environment's *Technical Guide to Renewable Energy Approvals* (October, 2013). Given the nature of this technical update, the *Heritage Assessment* does not require any additional assessment. As such, the update is being provided for MTCS's information.

REPORT REVIEW

Stantec reviewed the *Heritage Assessment*. There were 24 built heritage resources and four cultural heritage landscapes identified as part of the study. Recommendations were prepared to mitigate any potential impacts identified based on an understanding of the Project at that time. These recommendations were as follows:

A total of 24 built heritage resources and four cultural heritage landscapes have been identified and assessed by this study for potential Project-related negative impacts. A summary of potentially affected resources and landscapes and recommended mitigation is presented in Table 25.

Table 25 Summary of Recommended Mitigation

BHR/CHL #	Address/Name	Recommended Mitigation
BHR 4 BHR 5 BHR 6 BHR 19 BHR 20 BHR 21	3500 South Shore Road 4125 South Shore Road 2750 Front Road 3475 Second Concession Road 4725 Second Concession Road 5950 Second Concession Road	<ul style="list-style-type: none"> • Avoid Project activities within a 50 m bufferzone of structures on the property. • In the event that Project activities within a 50 m bufferzone cannot be avoided, it is recommended that maximum acceptable vibration, or peak particle velocity (PPV), levels be determined by a qualified engineer prior to Project activities and that activities be monitored to ensure that maximum PPV levels are not exceeded. • All Project activities should cease if levels are exceeded until a solution can be determined.
BHR 7	3190 Front Road	<ul style="list-style-type: none"> • Avoid Project activities within a 50 m bufferzone of structures or dry stone walls on the property.



Reference: Amherst Island Wind Energy Project Heritage Assessment – Project Layout Modifications

BHR/CHL #	Address/Name	Recommended Mitigation
BHR 18	Emerald 40 Foot Road and Second Concession Road	<ul style="list-style-type: none"> In the event that Project activities within a 50 m bufferzone cannot be avoided, it is recommended that maximum acceptable vibration, or peak particle velocity (PPV), levels be determined by a qualified engineer prior to Project activities be monitored to ensure that maximum PPV levels are not exceeded. Prior to any Project activities within 50 m of the property, the dry stone wall and any building containing heritage value should be documented. Any damage resulting from the construction should be repaired to a pre-Project state immediately following construction.
CHL 4	Ferry Landscape	<ul style="list-style-type: none"> Documentation of ferry landscape prior to the construction of permanent and temporary Project infrastructure.
CHL 1	Village of Stella	<ul style="list-style-type: none"> Avoid Project activities within a 50 m bufferzone of any structures in the CHL. In the event that Project activities within a 50 m bufferzone cannot be avoided, it is recommended that maximum acceptable vibration, or peak particle velocity (PPV), levels be determined by a qualified engineer prior to Project activities and that activities be monitored to ensure that maximum PPV levels are not exceeded. Photographically record condition of burial vault and monitor its physical condition during construction process. All Project activities should cease if levels are exceeded until a solution can be determined.
CHL 3	St. Paul's Presbyterian Church	

In order to lessen or avoid potential indirect negative impacts from construction vibrations on BHRs 4, 5, 6, 19, 20 and 21 and components of CHLs 1 and 3, the following recommendations have been made:

- Project activities should be avoided within 50 m of identified BHRs and any structures or buildings within identified CHLs.



December 1, 2014

Laura Hatcher, MCIP, RPP, Team Lead: Heritage Land Use Planning

Page 6 of 12

Reference: Amherst Island Wind Energy Project Heritage Assessment – Project Layout Modifications

- *If Project activities within a 50 m bufferzone cannot be avoided, maximum acceptable vibration levels, or peak particle velocity (PPV) levels, should be determined by a qualified engineer with previous experience working with built heritage resources under similar circumstances.*
- *Project activities within the 50 m bufferzone should be monitored to ensure that PPV levels are not exceeded.*
- *All Project activities should cease immediately if levels are exceeded until a solution can be determined.*

With respect to the dry stone walls associated with BHRs 7 and 18, the following recommendations have been made:

- *It is recommended that Project activities be avoided within a 50 m bufferzone of any dry stone walls.*
- *In the event that Project activities cannot be avoided within 50 m of any dry stone wall, the wall should be documented prior to the commencement of said activities.*
- *The stone wall should be assessed periodically by a qualified individual during Project activities to ensure that no damage is occurring.*
- *Project activities should cease immediately if vibrations are found to be resulting in damage until the wall can be adequately reinforced or supported.*
- *The stone wall should be evaluated by a qualified mason or engineer following Project activities to ensure that no damage has occurred and any damage to the wall should be repaired immediately following Project activities.*
- *Finally, prior to construction of shoreline Project infrastructure, views from the Ferry Landscape should be more thoroughly documented, particularly towards the proposed locations of new permanent and temporary infrastructure. This documentation should include, at the very least, a photographic record of existing conditions and views.*

It was determined that the impact assessment contained within the Report is valid but requires updating to reflect the proposed modifications. Specifically, 2450 South Shore Road (BHR 3) was evaluated for impacts associated with turbines positioned at the rear of the property. This assessment must be expanded to include potential impacts associated with the installation of collector lines at the front of the property and along the public road allowance.

Finally, it was determined that in four cases, where potential impacts were identified as a result of proposed Project infrastructure, this infrastructure had been removed. Therefore, potential impacts



Reference: Amherst Island Wind Energy Project Heritage Assessment – Project Layout Modifications

were no longer anticipated in these cases. In one case, additional project infrastructure was proposed. This is summarized in Table 1.

Municipal Address, BHR/CHL #	Relationship to Additional Infrastructure	Relationship to Removed Infrastructure	Additional Assessment Required
1830 South Shore Road, BHR 1	None	None	No
2090 South Shore Road, BHR 2	None	None	No
2450 South Shore Road, BHR 3	Adjacent	None	Yes
3500 South Shore Road, BHR 4	None	None	No
4125 South Shore Road, BHR 5	None	None	No
2750 Front Road, BHR 6	None	None	No
3190 Front Road, BHR 7	None	Adjacent	No
12405 Front Road, BHR 8	None	None	No
12515 Front Road, BHR 9	None	None	No
12525 Front Road, BHR 10	None	None	No
12675 Front Road, BHR 11	None	None	No
12945 Front Road, BHR 12	None	None	No
13555 Front Road, BHR 13	None	None	No
13895 Front Road, BHR 14	None	None	No
14005 Front Road, BHR 15	None	None	No
14005 Front Road, BHR 15	None	None	No
15095 Front Road, BHR 16	None	None	No
20 Emerald 40 Foot Road, BHR 17	None	None	No
Emerald 40 Foot Road & Second Concession Road, BHR 18	None	Adjacent	No
3475 Second Concession Road, BHR 19	None	None	No
4725 Second Concession Road, BHR 20	None	Adjacent	No



December 1, 2014

Laura Hatcher, MCIP, RPP, Team Lead: Heritage Land Use Planning

Page 8 of 12

Reference: Amherst Island Wind Energy Project Heritage Assessment – Project Layout Modifications

Municipal Address, BHR/CHL #	Relationship to Additional Infrastructure	Relationship to Removed Infrastructure	Additional Assessment Required
5950 Second Concession Road, BHR 21	None	Adjacent	No
3775 Third Concession Road, BHR 22	None	None	No
Lighthouse, BHR 23	None	None	No
5330 Bath Road, BHR 24	None	None	No
Village of Stella Cultural Heritage Landscape, CHL 1	None	None	No
Catholic Cemetery, CHL 2	None	None	No
St. Paul's Presbyterian Church, CHL 3	None	None	No
Ferry Landscape, CHL 4	None	None	No

FIELD ASSESSMENT

In order to identify the presence of potential heritage resources where modifications are proposed, a field assessment was completed. The assessment was undertaken by Meaghan Rivard, Heritage Consultant with Stantec, on Monday, October 27, 2014 under clear conditions. The field assessment was restricted to properties where new Project infrastructure is proposed and thus was limited to South Shore Road between Turbines S13 and S14, and the north portion of 2nd Concession Road, west of Stella 40 Foot Road and east of Kerr Point Road.

IMPACT ASSESSMENT

Impact assessments contained within the *Heritage Assessment* were determined to remain valid for all properties excluding BHR 3, 7, 18, 20, and 21. While in some cases the assessment addressed turbines which are no longer proposed or residences that no longer exist, it is only in the case of 2450 South Shore Road (BHR 3) where new infrastructure is proposed near the location that has not been assessed. Therefore, an impact assessment was undertaken in addition to the assessment completed as part of the *Heritage Assessment*.

The findings of the impact assessment are summarized in Table 2. It was determined that, given the vicinity of the resource to the newly proposed collector lines positioned underground within the municipal right of way (approximately 40 metres), there are no direct Project related negative impacts expected. However, there is the potential for indirect impacts resulting from construction

Design with community in mind



December 1, 2014

Laura Hatcher, MCIP, RPP, Team Lead: Heritage Land Use Planning

Page 9 of 12

Reference: Amherst Island Wind Energy Project Heritage Assessment – Project Layout Modifications

vibrations. With the identification of a new potential impact resulting from proposed Project modifications, mitigation measures are required.

Table 2 Direct and Indirect Impacts	
Potential Impact	Relevance to 2450 South Shore Road (BHR 3)
Destruction of any, or part of any, significant heritage attributes or features	No direct Project related negative impacts expected with respect to destruction; however, there is the potential for indirect impacts resulting from construction vibrations.
Alteration that is not sympathetic, or is incompatible, with the historic fabric and appearance	Not anticipated; alterations are restricted to the municipal right of way and are not anticipated to enter onto the property.
Shadows created that alter the appearance of a heritage attribute or change the viability of a natural feature or plantings, such as a garden	Not anticipated; below ground collector cables will not result in the creation of shadows.
Isolation of a heritage attribute from its surrounding environment, context or a significant relationship	Not anticipated; identified heritage attributes will remain connected with the surrounding area.
Direct or indirect obstruction of significant views or vistas within, from, or of built and natural features	Not anticipated; no significant views or vistas identified.
A change in land use such as rezoning a battlefield from open space to residential use, allowing new development or sit alteration to fill the formerly open spaces	Not anticipated; the land use will remain unaltered.
Land disturbances such as a change in grade that alters soils, and drainage patterns that adversely affect an archaeological resource	Not applicable; archaeological resources are considered in the Archaeological Assessment Reports (various stages).

RECOMMENDED MITIGATION

The potential for indirect impacts resulting from construction vibrations was identified during an impact assessment of 2450 South Shore Road (BHR 3). The impact was similar to that identified for BHRs 4, 5, 6, 19, 20, and 21 in the 2013 *Heritage Assessment*. Given the similarity in distance anticipated between the construction area and the resource, it was determined that mitigation recommendations contained within the Report would be appropriate. Therefore, Project activities should first be avoided within a 50 metre bufferzone surrounding the residence. Where this is activity cannot be avoided, maximum acceptable vibration levels should be determined and



Reference: Amherst Island Wind Energy Project Heritage Assessment – Project Layout Modifications

monitored. If these levels are exceeded, all Project activities should cease until a solution can be determined.

RECOMMENDATIONS

Based on these findings, it was determined the recommendations contained within the *Heritage Assessment* should be modified to reflect areas where additional assessment was undertaken as well as those where recommendations are no longer valid. We ask that the MTCS review the attached figures illustrating the proposed Project modification as well as the impact assessment contained within this letter. Following review, if appropriate, we request revision of the confirmation letter received by Stantec on April 17, 2013, to incorporate the revised recommendations as follows:

A summary of potentially affected resources and landscapes and recommended mitigation is presented in the table below.

Summary of Recommended Mitigation

BHR/CHL #	Address/Name	Recommended Mitigation
BHR 3 BHR 4 BHR 5 BHR 6 BHR 19	2400 South Shore Road 3500 South Shore Road 4125 South Shore Road 2750 Front Road 3475 Second Concession Road	<ul style="list-style-type: none">• Avoid Project activities within a 50 m bufferzone of structures on the property.• In the event that Project activities within a 50 m bufferzone cannot be avoided, it is recommended that maximum acceptable vibration, or peak particle velocity (PPV), levels be determined by a qualified engineer prior to Project activities and that activities be monitored to ensure that maximum PPV levels are not exceeded.• All Project activities should cease if levels are exceeded until a solution can be determined.
CHL 4	Ferry Landscape	<ul style="list-style-type: none">• Documentation of ferry landscape prior to the construction of permanent and temporary Project infrastructure.



Reference: Amherst Island Wind Energy Project Heritage Assessment – Project Layout Modifications

BHR/CHL #	Address/Name	Recommended Mitigation
CHL 1 CHL 3	Village of Stella St. Paul's Presbyterian Church	<ul style="list-style-type: none"> • Avoid Project activities within a 50 m bufferzone of any structures in the CHL. • In the event that Project activities within a 50 m bufferzone cannot be avoided, it is recommended that maximum acceptable vibration, or peak particle velocity (PPV), levels be determined by a qualified engineer prior to Project activities and that activities be monitored to ensure that maximum PPV levels are not exceeded. • Photographically record condition of burial vault and monitor its physical condition during construction process. • All Project activities should cease if levels are exceeded until a solution can be determined.

In order to lessen or avoid potential indirect negative impacts from construction vibrations on BHRs 4, 5, 6, and 19 and components of CHLs 1 and 3, the following recommendations have been made:

- Project activities should be avoided within 50 m of identified BHRs and any structures or buildings within identified CHLs.
- If Project activities within a 50 m bufferzone cannot be avoided, maximum acceptable vibration levels, or peak particle velocity (PPV) levels, should be determined by a qualified engineer with previous experience working with built heritage resources under similar circumstances.
- Project activities within the 50 m bufferzone should be monitored to ensure that PPV levels are not exceeded.
- All Project activities should cease immediately if levels are exceeded until a solution can be determined.

With respect to the dry stone walls associated with BHRs 7 and 18, while potential impacts are not anticipated, the following recommendations have been made and should be applied to previously identified resources as well as those encountered during Project construction activities:

- It is recommended that Project activities be avoided within a 50 m bufferzone of any dry stone walls.



December 1, 2014

Laura Hatcher, MCIP, RPP, Team Lead: Heritage Land Use Planning

Page 12 of 12

Reference: Amherst Island Wind Energy Project Heritage Assessment – Project Layout Modifications

- *In the event that Project activities cannot be avoided within 50 m of any dry stone wall, the wall should be documented prior to the commencement of said activities.*
- *The stone wall should be assessed periodically by a qualified individual during Project activities to ensure that no damage is occurring.*
- *Project activities should cease immediately if vibrations are found to be resulting in damage until the wall can be adequately reinforced or supported.*
- *The stone wall should be evaluated by a qualified mason or engineer following Project activities to ensure that no damage has occurred and any damage to the wall should be repaired immediately following Project activities.*

Finally, prior to construction of shoreline Project infrastructure, views from the Ferry Landscape should be more thoroughly documented, particularly towards the proposed locations of new permanent and temporary infrastructure. This documentation should include, at the very least, a photographic record of existing conditions and views.

Regards,

STANTEC CONSULTING LTD.

A handwritten signature in black ink that reads "Meaghan Rivard".

Meaghan Rivard, MA, CAHP

Heritage Specialist

Phone: 519-575-4114

Meaghan.Rivard@stantec.com

Attachment: Project Location & Study Area: Proposed Modifications

c. Colin Varley, Stantec Consulting Ltd.

Kerrie Skillen, Stantec Consulting Ltd.

rm \\cd1220-f02\root\work_group\01609\active\60960595\reports\03_modification reports\rep_modification_no. 3_draft\ha assessment mod\let_60595_heritage_addendum_final.docx

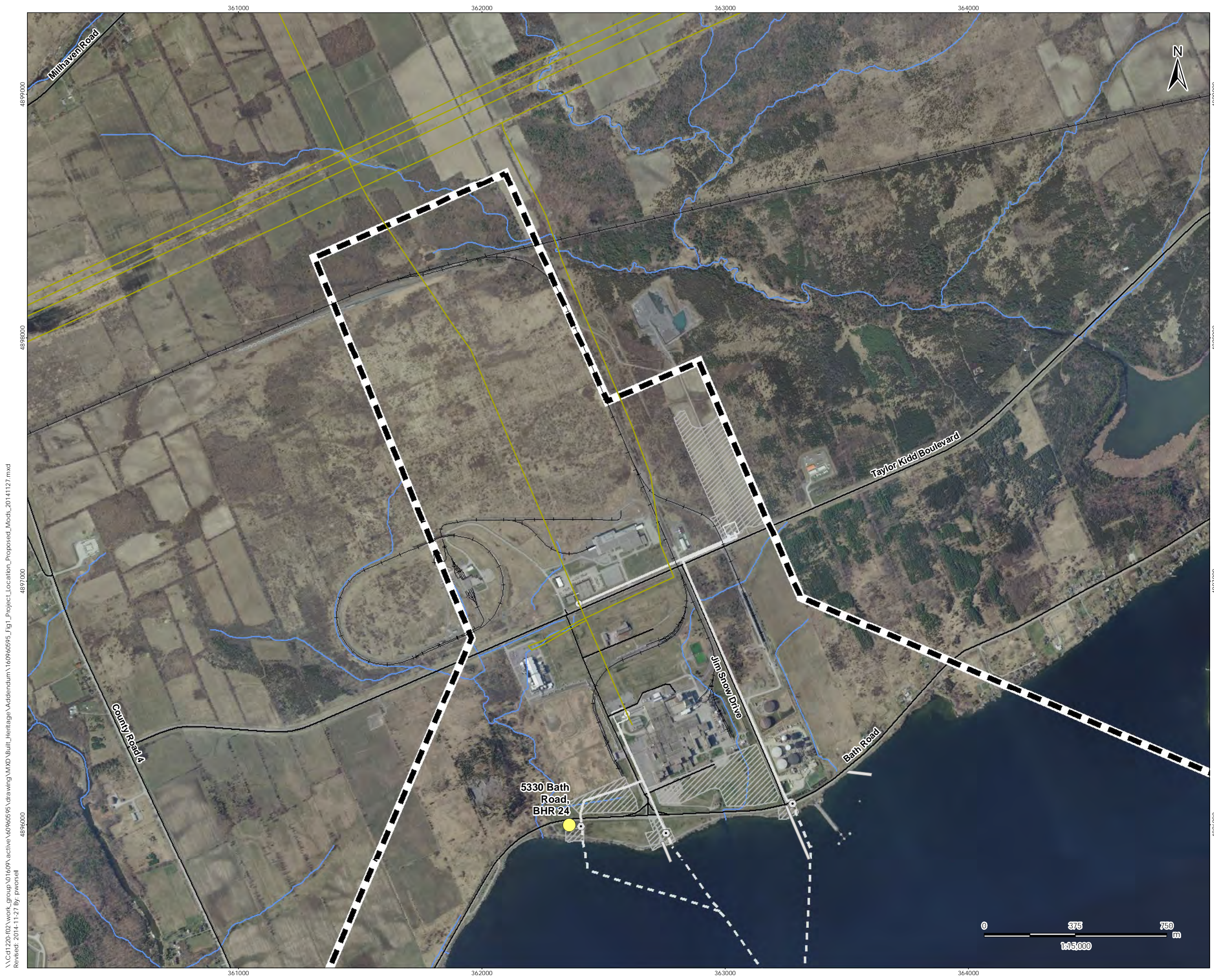

Legend

- Study Area
- Built Heritage Resource
- Protected Property
- Cultural Heritage Landscape
- Stone Fence
- Project Components**
- Turbine (No Changes Proposed)
- Turbine (Removed)
- Met Tower - Potential Location (No Changes Proposed)
- Met Tower - Potential Location (Removed)
- Other Project Component (No Changes Proposed)
- Other Project Component (New)
- Other Project Component (Removed)
- Existing Features**
- Road
- Unopened Road Allowance
- Railway
- Hydro Line
- Watercourse
- Property Line

Notes

1. Coordinate System: NAD 1983 UTM Zone 18N
2. Base features produced under license with the Ontario Ministry of Natural Resources © Queen's Printer for Ontario, 2014.
3. Orthoimagery © First Base Solutions, 2014. Imagery taken in 2008.

November 2014
160960595

Client/Project

Windlectric Inc.
Amherst Island Wind Energy Project

Figure No.

1.1

Title

Project Location & Study Area:
Proposed Modifications



\\Cd1220-102\work_group\01609\active\60960595\drawing\MXD\Built_Heritage\Addendum\160960595_Fig1_Project_Location_Proposed_Mods_20141127.mxd
 Revised: 2014-11-27 By: p.worsell

Legend

- Study Area
- Built Heritage Resource
- Protected Property
- Cultural Heritage Landscape
- Stone Fence
- Project Components**
- Turbine (No Changes Proposed)
- Turbine (Removed)
- Met Tower - Potential Location (No Changes Proposed)
- Met Tower - Potential Location (Removed)
- Other Project Component (No Changes Proposed)
- Other Project Component (New)
- Other Project Component (Removed)
- Existing Features**
- Road
- Unopened Road Allowance
- Railway
- Hydro Line
- Watercourse
- Property Line

Notes

1. Coordinate System: NAD 1983 UTM Zone 18N
2. Base features produced under license with the Ontario Ministry of Natural Resources © Queen's Printer for Ontario, 2014.
3. Orthoimagery © First Base Solutions, 2014. Imagery taken in 2008.

November 2014
160960595

Client/Project

Windlectric Inc.
Amherst Island Wind Energy Project

Figure No.

1.2

Title

Project Location & Study Area:
Proposed Modifications



\\C:\1220-102\work_group\01609\active\60960595\drawing\MXD\Built_Heritage\Addendum\160960595_Fig1_Project_Location_Proposed_Mods_20141127.mxd
 Revised: 2014-11-27 By: pworsell

366000 367000 368000 369000 370000



Legend

- Study Area
- Built Heritage Resource
- Protected Property
- Cultural Heritage Landscape
- Stone Fence
- Project Components
 - Turbine (No Changes Proposed)
 - Turbine (Removed)
 - Met Tower - Potential Location (No Changes Proposed)
 - Met Tower - Potential Location (Removed)
 - Other Project Component (No Changes Proposed)
 - Other Project Component (New)
 - Other Project Component (Removed)
- Existing Features
 - Road
 - Unopened Road Allowance
 - Railway
 - Hydro Line
 - Watercourse
 - Property Line



- Notes
1. Coordinate System: NAD 1983 UTM Zone 18N
 2. Base features produced under license with the Ontario Ministry of Natural Resources © Queen's Printer for Ontario, 2014.
 3. Orthoimagery © First Base Solutions, 2014. Imagery taken in 2008.

November 2014
160960595

Client/Project
Windlectric Inc.
Amherst Island Wind Energy Project

Figure No.
1.3

Title
Project Location & Study Area:
Proposed Modifications



366000 367000 368000 369000 370000

\\C:\1220-102\work_group\01609\active\60960595\drawing\MXD\Built_Heritage\Addendum\160960595_Fig1_Project_Location_Proposed_Mods_20141117.mxd
Revised: 2014-11-27 By: p.worsell

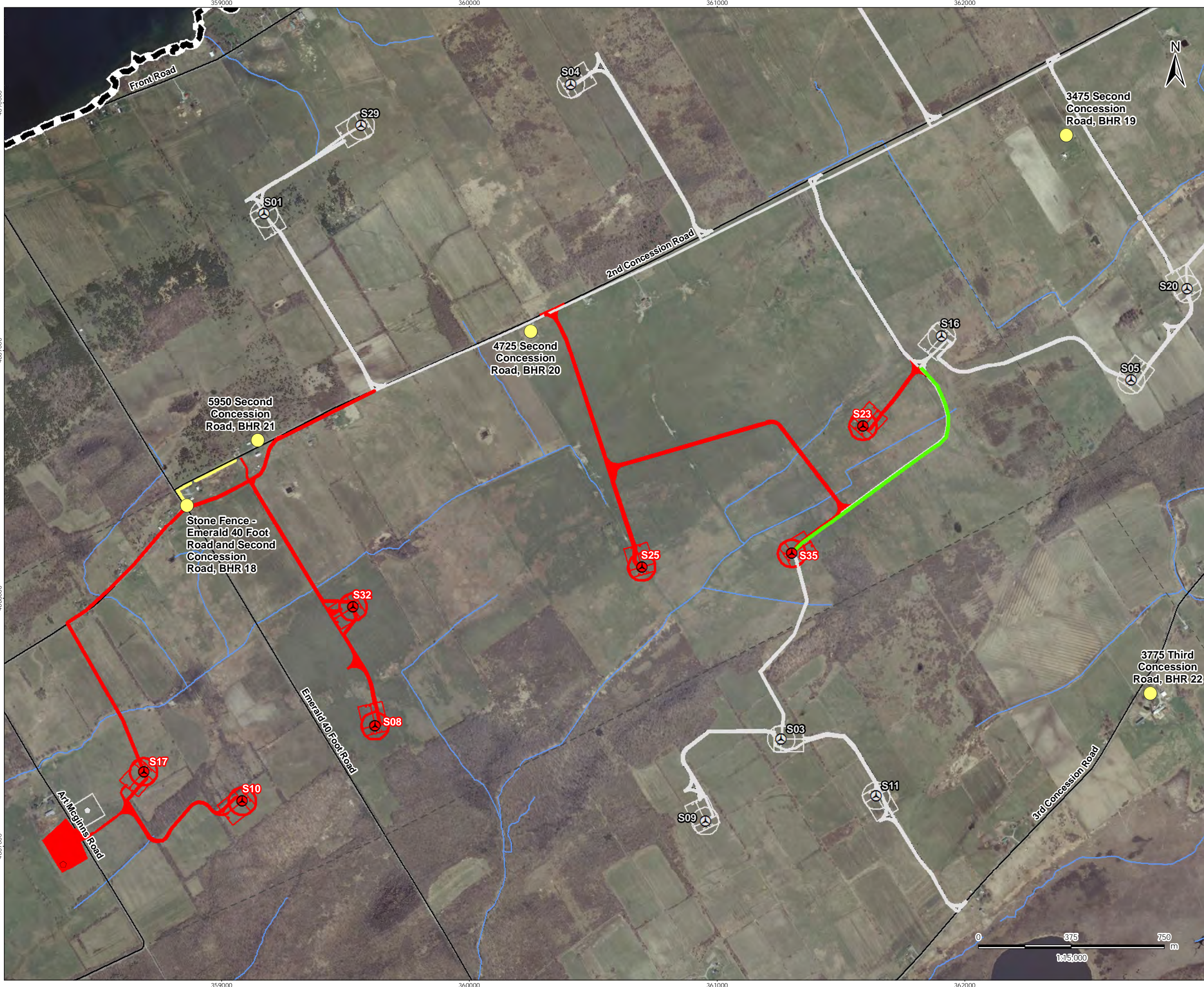

Legend

- Study Area
- Built Heritage Resource
- Protected Property
- Cultural Heritage Landscape
- Stone Fence

Project Components

- Turbine (No Changes Proposed)
- Turbine (Removed)
- Met Tower - Potential Location (No Changes Proposed)
- Met Tower - Potential Location (Removed)
- Other Project Component (No Changes Proposed)
- Other Project Component (New)
- Other Project Component (Removed)

Existing Features

- Road
- Unopened Road Allowance
- Railway
- Hydro Line
- Watercourse
- Property Line

Notes

1. Coordinate System: NAD 1983 UTM Zone 18N
2. Base features produced under license with the Ontario Ministry of Natural Resources © Queen's Printer for Ontario, 2014.
3. Orthoimagery © First Base Solutions, 2014. Imagery taken in 2008.

November 2014
160960595

Client/Project
Windlectric Inc.
Amherst Island Wind Energy Project

Figure No.
1.4

Title
Project Location & Study Area:
Proposed Modifications

\\C:\1220-102\work_group\01609\active\60960595\drawing\MXD\Built_Heritage\Addendum\160960595_Fig1_Project_Location_Proposed_Mods_20141127.mxd
 Revised: 2014-11-27 By: p.worsell



Legend

- Study Area
- Built Heritage Resource
- Protected Property
- Cultural Heritage Landscape
- Stone Fence
- Project Components**
- Turbine (No Changes Proposed)
- Turbine (Removed)
- Met Tower - Potential Location (No Changes Proposed)
- Met Tower - Potential Location (Removed)
- Other Project Component (No Changes Proposed)
- Other Project Component (New)
- Other Project Component (Removed)
- Existing Features**
- Road
- Unopened Road Allowance
- Railway
- Hydro Line
- Watercourse
- Property Line

Notes

1. Coordinate System: NAD 1983 UTM Zone 18N
2. Base features produced under license with the Ontario Ministry of Natural Resources © Queen's Printer for Ontario, 2014.
3. Orthoimagery © First Base Solutions, 2014. Imagery taken in 2008.

November 2014
160960595

Client/Project

Windlectric Inc.
Amherst Island Wind Energy Project

Figure No.

1.5

Title

Project Location & Study Area:
Proposed Modifications





\\Cd1220-102\work_group\01609\active\60960595\drawing\MXD\Built_Heritage\Addendum\160960595_Fig1_Project_Location_Proposed_Mods_20141117.mxd
 Revised: 2014-11-27 By: pwnorsell
 4887000

367900

368000

368100

Legend

-  Study Area
 -  Built Heritage Resource
 -  Collector Line (New)
- Existing Features**
-  Road
 -  Property Line



\\C:\1220-102\work_group\01609\active\60960595\drawing\MXD\Built_Heritage\Addendum\160960595_Fig2_2450_South_Shore_Road_20141127.mxd
 Revised: 2014-11-27 By: pworthell
 4891100



Notes

1. Coordinate System: NAD 1983 UTM Zone 18N
2. Base features produced under license with the Ontario Ministry of Natural Resources © Queen's Printer for Ontario, 2014.
3. Orthoimagery © First Base Solutions, 2014. Imagery taken in 2008.

November 2014
160960595

Client/Project
Windlectric Inc.
Amherst Island Wind Energy Project

Figure No.
2

Title
**Built Heritage Resources -
2450 South Shore Road (BHR3)**

367900

368000

368100

4891300

4891200

4891100

4891300

4891200

4891100

**Ministry of Tourism, Culture
and Sport**

Culture Services Unit
Programs and Services Branch
Culture Division
401 Bay Street, Suite 1700
Toronto ON M7A 0A7
Tel: 416 314-7620
Fax: 416 212-1802

**Ministère du Tourisme, de la Culture
et du Sport**

Unité des services culturels
Direction des programmes et des services
Division de culture
401, rue Bay, bureau 1700
Toronto ON M7A 0A7
Tél: 416 314-7620
Télé: 416 212-1802



December 19, 2014

Ms. Meaghan Rivard
Heritage Consultant
Stantec
49 Frederick Street
Kitchener ON
N2H 6M7

Project: Amherst Island Wind Energy Project
OPA Reference Number: F-004563-WIN-130-601
Report Title: Addendum to Heritage Assessment - Project Layout
Modifications
Applicant: Windlectric Inc.
Location: Amherst Island, Township of Loyalist, County of Lennox and
Addington
MTCS File No.: 16EA025

Dear Ms. Rivard:

This office has reviewed the above-mentioned addendum to the heritage assessment report (the "Addendum"), which has been submitted to this ministry as required under O. Reg. 359/09, as amended (Renewable Energy Approvals under the *Environmental Protection Act*) (the "REA regulation") to address changes to the project layout. This letter constitutes the Ministry of Tourism, Culture and Sport (the "Ministry") comments for the purposes of section 23(3)(a) of the REA regulation regarding the heritage assessment undertaken for the above project, and replaces our previous comment letter from April 17, 2013.

The Addendum recommends the following:

RECOMMENDATIONS

Based on these findings, it was determined the recommendations contained within the *Heritage Assessment* should be modified to reflect areas where additional assessment was undertaken as well as those where recommendations are no longer valid. We ask that the MTCS review the attached figures illustrating the proposed Project modification as well as the impact assessment contained within this letter. Following review, if appropriate, we request revision of the confirmation letter received by Stantec on April 17, 2013, to incorporate the revised recommendations as follows:

BHR/CHL #	Address/Name	Recommended Mitigation
BHR 3 BHR 4 BHR 5 BHR 6 BHR 19	2400 South Shore Road 3500 South Shore Road 4125 South Shore Road 2750 Front Road 3475 Second Concession Road	<ul style="list-style-type: none"> • Avoid Project activities within a 50 m bufferzone of structures on the property. • In the event that Project activities within a 50 m bufferzone cannot be avoided, it is recommended that maximum acceptable vibration, or peak particle velocity (PPV), levels be determined by a qualified engineer prior to Project activities and that activities be monitored to ensure that maximum PPV levels are not exceeded. • All Project activities should cease if levels are exceeded until a solution can be determined.
CHL 4	Ferry Landscape	<ul style="list-style-type: none"> • Documentation of ferry landscape prior to the construction of permanent and temporary Project infrastructure.
CHL 1 CHL 3	Village of Stella St. Paul's Presbyterian Church	<ul style="list-style-type: none"> • Avoid Project activities within a 50 m bufferzone of any structures in the CHL. • In the event that Project activities within a 50 m bufferzone cannot be avoided, it is recommended that maximum acceptable vibration, or peak particle velocity (PPV), levels be determined by a qualified engineer prior to Project activities and that activities be monitored to ensure that maximum PPV levels are not exceeded. • Photographically record condition of burial vault and monitor its physical condition during construction process. • All Project activities should cease if levels are exceeded until a solution can be determined.

In order to lessen or avoid potential indirect negative impacts from construction vibrations on BHRs 4, 5, 6, and 19 and components of CHLs 1 and 3, the following recommendations have been made:

- Project activities should be avoided within 50m of identified BHRs and any structures or buildings within identified CHLs.
- If Project activities within a 50 m bufferzone cannot be avoided, maximum acceptable vibration levels, or peak particle velocity (PPV) levels, should be determined by a qualified engineer with previous experience working with built heritage resources under similar circumstances.
- Project activities within the 50 m bufferzone should be monitored to ensure that PPV levels are not exceeded.
- All Project activities should cease immediately if levels are exceeded until a solution can be determined.

With respect to the dry stone walls associated with BHRs 7 and 18, while potential impacts are not anticipated, the following recommendations have been made and should be applied to previously identified resources as well as those encountered during Project construction activities:

- It is recommended that Project activities be avoided within a 50 m bufferzone of any dry stone walls.
- In the event that Project activities cannot be avoided within 50 m of any dry stone wall, the wall should be documented prior to the commencement of said activities.
- The stone wall should be assessed periodically by a qualified individual during Project activities to ensure that no damage is occurring.
- Project activities should cease immediately if vibrations are found to be resulting in damage until the wall can be adequately reinforced or supported.
- The stone wall should be evaluated by a qualified mason or engineer following Project activities to ensure that no damage has occurred and any damage to the wall should be repaired immediately following Project activities.

Finally, prior to construction of shoreline Project infrastructure, views from the Ferry Landscape should be more thoroughly documented, particularly towards the proposed locations of new permanent and temporary infrastructure. This documentation should include, at the very least, a photographic record of existing conditions and views.

Based on the information contained in the Addendum and the heritage assessment report, the Ministry is satisfied that the heritage assessment process and reporting are consistent with the applicable heritage assessment requirements established in s. 23 of O. Reg. 359/09. Please note that the Ministry makes no representation or warranty as to the completeness, accuracy or quality of the heritage assessment report (please see Note 1).

This letter does not waive any requirements under the *Ontario Heritage Act*.

This letter does not constitute approval of the renewable energy project. Approvals or licences for the project may be required under other statutes and regulations. Please ensure that you obtain all required approvals and/or licences.

Please ensure that the proponent is aware that, if new information or substantive project changes arise after issuance of this letter, the applicant should discuss them with you to determine if any additional assessment or reporting is required. If additional reporting or revisions are required, they should be submitted to the Ministry for review. Upon completion of that review, the Ministry will determine if any revisions to the content of this letter are required.

Should you have any questions or require further information, please do not hesitate to contact me.

Sincerely,

Laura Hatcher

Team Lead (A) – Heritage Land Use Planning

416-314-3108

laura.e.hatcher@ontario.ca

cc. Sean Fairfield, Senior Project Manager
Algonquin Power

Agatha Garcia-Wright, Director
Environmental Approvals Access & Service Integration Branch, Ministry of the Environment

Sarah Paul, Director
Environmental Approvals Branch, Ministry of the Environment

Paula Kulpa, Manager (A)
Culture Services Unit, Ministry of Tourism, Culture and Sport

Note 1: In no way will the Ministry be liable for any harm, damages, costs, expenses, losses, claims or actions that may result: (a) if the Report or its recommendations are discovered to be inaccurate, incomplete, misleading or fraudulent; or (b) from the issuance of this letter. Further measures may need to be taken in the event that additional heritage resources are identified or the Report is otherwise found to be inaccurate, incomplete, misleading or fraudulent.



Stantec Consulting Ltd.
49 Frederick Street, Kitchener ON N2H 6M7

December 1, 2014
File: 160960595

Attention: Laura Hatcher, MCIP, RPP, Team Lead: Heritage Land Use Planning

Culture Services Unit
Programs and Services Branch
Ministry of Tourism, Culture and Sport
401 Bay Street Suite
1700 Toronto ON M7A 0A7

Dear Ms. Hatcher,

Reference: Amherst Island Wind Energy Project Protected Properties – Project Layout Modifications

Algonquin Power (on behalf of Windlectric Inc.) is developing the Amherst Island Wind Energy Project (the Project), a proposed 75MW wind energy project on Amherst Island, located within Loyalist Township in the County of Lennox and Addington in eastern Ontario. As discussed with Ministry of Tourism, Culture and Sport (MTCS) on Tuesday, November 4, 2014, Algonquin Power is considering three modifications to the REA application for the Amherst Island Wind Project.

This letter is submitted as an addendum to the Project Renewable Energy Approval Application – *Protected Properties Assessment* that was submitted to the MTCS in April 2013 and for which a letter of satisfaction was received on April 5, 2013.

The purpose of this letter is to provide the MTCS with an understanding of modifications that have been made to the location of the Project (details are listed below) since the *Protected Properties Assessment* was confirmed by the MTCS, and to provide an assessment of the proposed modifications in order to identify any additional potential effects, mitigation measures, or monitoring requirements that were not included in the *Protected Properties Assessment*. For the purposes of this summary, only additional infrastructure was assessed.

PROJECT DESCRIPTION

The basic components of the proposed Project include up to 36 Siemens wind turbines. The final layout will result in a total installed nameplate capacity of approximately 56 - 75 MW. The number of wind turbines will be dependent upon final selection of the model of the wind turbine most appropriate to the proposed Project.

At the time of the 2013 *Protected Properties Assessment*, the turbine model proposed utilized 36 turbine pad locations that have been subject to the assessment required under REA. The layout in the original REA application included 34 Siemens SWT-2.3-113 2300 kW and two (2) Siemens SWT-2.3-113 2221 kW model wind turbines.



December 1, 2014

Laura Hatcher, MCIP, RPP, Team Lead: Heritage Land Use Planning

Page 2 of 6

Reference: Amherst Island Wind Energy Project Protected Properties – Project Layout Modifications

The proposed Project will also include a 34.5 kilovolt (kV) underground and/or overhead electrical power line collector system, fibre optic data lines from each turbine and/or wireless technology for the communication of data, a transmission line, truck turnaround areas, a submarine cable, an operations and maintenance building, permanent dock, a substation, a switching station, an un-serviced storage shed, one connection point to the existing electrical system, cable vault areas, meteorological tower(s) (met tower(s)), access road(s) to the met tower site(s), and turbine access roads with culvert installations, as required, at associated watercourse crossings. It is understood that the collector system, including the collector and transmission lines, will be positioned below ground.

Temporary components during construction may include staging areas for the turbines, access roads, met tower(s), collector lines and transmission line as well as crane paths, a temporary dock, site office(s), batch plant, central staging areas, and associated watercourse crossings. The electrical power line collector system would transport the electricity generated from each turbine to the substation, along the submarine cable to the mainland and then to a switching station located near to an existing Hydro One Networks Inc. (HONI) 115 kV transmission line.

HERITAGE CONTEXT

Stantec was retained by Algonquin Power Co. on behalf of the Proponent to undertake the cultural heritage and protected properties assessments for the Project as required by *Ontario Regulation 359/09*. Both Reports received written comments expressing satisfaction from the MTCS in April, 2013. Representatives from Algonquin Power Co., Stantec, and the MTCS met via tele-conference to discuss proposed modifications on November 4, 2014. It was determined during that time that, as is the standard process for filing modifications following receipt of a letter of satisfaction, Stantec would prepare a letter summarizing the proposed changes and implications, if any, on cultural heritage resources.

PROPOSED MODIFICATION DESCRIPTION

There are three modifications which have been proposed following the completion of the *Protected Properties Assessment*. These are: (1) a change in turbine model and associated reduction in the number of turbines, (2) a change in collection system routing to avoid the Village of Stella and (3) changes to the road and collection system to avoid some activities on 2nd Concession.

Further detail is provided below regarding the proposed modifications.

1. Reducing the number of Wind Turbines by changing Turbine Model (Siemens 2.942 MW and 2.772 MW)



December 1, 2014

Laura Hatcher, MCIP, RPP, Team Lead: Heritage Land Use Planning

Page 3 of 6

Reference: Amherst Island Wind Energy Project Protected Properties – Project Layout Modifications

This modification involves changing the Project's turbines from a combination of Siemens 2.3 MW and 2.221 MW to a combination of Siemens 2.942 MW and 2.772 MW, and thereby reducing the number of turbines from 36 to 27. The new turbines would be physically identical, specifically with a hub height of 99.5 m and rotor diameter of 113 m. The modification will decrease the Project Location size by reducing the number of turbine sites from 36 to 27. All of these 27 turbine sites are in previously studied and proposed locations.

The project modification has been discussed with the Ministry of the Environment and Climate Change (MOECC). The MOECC has verified this project modification is a Technical Change as pursuant to the classification system outlined in the Ministry of the Environment's *Technical Guide to Renewable Energy Approvals* (October, 2013). Given the nature of this technical update, the Protected Properties Assessment does not require any additional assessment. As such, the update is being provided for MTCS's information.

2. Collection System Route Change 1 – Avoiding the Village of Stella

This proposed modification would involve rerouting the collection system to avoid the Village of Stella. In doing so, this modification would remove a significant portion of the existing collection system from S30 entrance along Front Road, including by removing approximately 4 km of road allowance trenching (including through Stella). The modification would also require a new collection corridor from S13 to South Shore Rd. and west to S14 entrance, which would consist of approximately 1 km in road allowance and 700 m of in pasture field. The modification will decrease the Project Location size by resulting in a net reduction of approximately 2 km of collection system trenching.

The project modification has been discussed with the Ministry of the Environment and Climate Change (MOECC). The MOECC has verified this project modification is a Project Design Change as pursuant to the classification system outlined in the Ministry of the Environment's *Technical Guide to Renewable Energy Approvals* (October, 2013). Additional assessment to determine the relationship between previously identified protected properties and the proposed modifications is necessary along South Shore Road in between Turbines S13 and S14. This was undertaken as described in the text below.

3. Collection System Route Change 2 – Reducing Impacts on 2nd Concession

This modification would involve the addition of an underground collector line along a previously approved access road between T16/T23 and T35. The collector line has been incorporated into the design of the access road between T16/23 and T35. The modification will decrease the Project Location size by eliminating the need to install a second collection circuit trench on approximately 3 km of 2nd Concession.



December 1, 2014

Laura Hatcher, MCIP, RPP, Team Lead: Heritage Land Use Planning

Page 4 of 6

Reference: Amherst Island Wind Energy Project Protected Properties – Project Layout Modifications

The project modification has been discussed with the Ministry of the Environment and Climate Change (MOECC). The MOECC has verified this project modification is a Technical Change as pursuant to the classification system outlined in the Ministry of the Environment's *Technical Guide to Renewable Energy Approvals* (October, 2013). Given the nature of this technical update, the Protected Properties Assessment does not require any additional assessment. As such, the update is being provided for MTCS's information.

REPORT REVIEW

Stantec reviewed the *Protected Properties Assessment*. There were three protected properties identified and the ongoing designation of numerous stone fences in the Study Area was noted.

The *Protected Properties Assessment* determined that:

A total of three (3) protected properties have been identified within the Study Area. These properties include:

- *Neilson's General Store at 5170 Front Road;*
- *Trinity United Church at 5555 Front Road; and*
- *Pentland Cemetery at 1652 Front Road.*

Potential negative impacts have been identified for all three properties.

This study recommends the following for the church and store:

- *Project activities within a 50 m bufferzone of the Trinity United Church and Neilson's Store should be avoided.*
- *If Project activities within a 50 m bufferzone cannot be avoided due to other Project constraints, it is recommended that maximum acceptable vibration, or peak particle velocity (PPV), levels for each building be determined by a qualified engineer with previous experience working with built heritage under similar circumstances prior to Project activities.*
- *Project activities should be monitored to ensure that maximum PPV levels are not exceeded.*
- *All Project activities should cease immediately if PPV levels are exceeded to determine a solution to ensure compliance with PPV levels.*

The study recommends the following for the cemetery:



December 1, 2014

Laura Hatcher, MCIP, RPP, Team Lead: Heritage Land Use Planning

Page 5 of 6

Reference: Amherst Island Wind Energy Project Protected Properties – Project Layout Modifications

- *The Operations and Maintenance Building location opposite the Pentland Cemetery should be avoided.*
- *Prior to Project activities within a 50 m bufferzone (i.e., collector line, transportation of Project components), it is recommended that the stone wall be fully documented. The stone wall should be assessed periodically by a qualified individual during Project activities to ensure that no damage is occurring. Project activities should cease immediately if vibrations are found to be resulting in damage until the wall can be adequately reinforced or supported.*
- *The stone wall should be evaluated by a qualified mason or engineer following construction activities in the vicinity of the cemetery to ensure that no damage has occurred. Any damage to the wall should be repaired immediately following construction activities.*
- *To minimize impacts from the Operation and Maintenance Building, trees and/ or shrubbery should be planted to shield this structure from view.*

Upon review, it has been determined that protected properties identified in the April 2013 *Protected Properties Assessment* are not situated within, or abutting, properties where new Project infrastructure is proposed. It was further determined that in three cases, Neilson's General Store, Trinity United Church, and Pentland Cemetery, all associated infrastructure has been removed (see Table 1). In each case, Project infrastructure has been removed as opposed to added. Therefore, it was determined that no additional assessment is required for protected properties identified during the April 2013 *Protected Properties Assessment*.

Table 1 Summary of Property Assessment and Requirements for Additional Assessment

Protected Property	Relationship to the Proposed Additional Infrastructure	Relationship to the Proposed Removed Infrastructure	Additional Assessment Required
Neilson's General Store (5170 Front Road)	None	Adjacent to removed infrastructure (collector line)	No
Trinity United Church (5555 Front Road)	None	Adjacent to removed infrastructure (collector line)	No
Pentland Cemetery (1652 Front Road)	None	Adjacent to removed infrastructure (Operation and Maintenance Building)	No



December 1, 2014
Laura Hatcher, MCIP, RPP, Team Lead: Heritage Land Use Planning
Page 6 of 6

Reference: Amherst Island Wind Energy Project Protected Properties – Project Layout Modifications

FINDINGS

Based on review of the *Protected Properties Assessment*, it was determined that no additional assessment is required. The recommendations contained within the Report address potential impacts that are no longer anticipated as a result of the removal of Project infrastructure. The recommendations as they exist in the 2013 Report address all designated properties at the time of the writing of the Report and not just those situated at, or abutting, the Project Location. As such, while the recommendations reach beyond properties where potential impacts are anticipated, the recommendations remain valid and are considered to satisfy requirements made under *Ontario Regulation 359/09*.

RECOMMENDATIONS

Based on these findings, it was determined that the analysis, assessment, and recommendations of the *Protected Properties Assessment* remain unchanged as a result of the proposed project layout modification.

We ask that the MTCS review the attached figures illustrating the proposed Project modification. Following review, if appropriate, we request confirmation of Stantec's review and MTCS comment regarding the proposed modification as related to recommendations of the *Protected Properties Assessment*.

Regards,

STANTEC CONSULTING LTD.

A handwritten signature in black ink that reads "Meaghan Rivard".

Meaghan Rivard, MA, CAHP
Heritage Specialist
Phone: 519-575-4114
Meaghan.Rivard@stantec.com

Attachment: Project Location & Study Area: Proposed Modifications

c. Colin Varley, Stantec Consulting Ltd.
Kerrie Skillen, Stantec Consulting Ltd.

rm \\cd1220-f02\root\work_group\01609\active\60960595\reports\03_modification reports\rep_modification_no. 3_draft\pp assessment
mod\let_60595_heritage_protectedproperties_addendum_final.docx

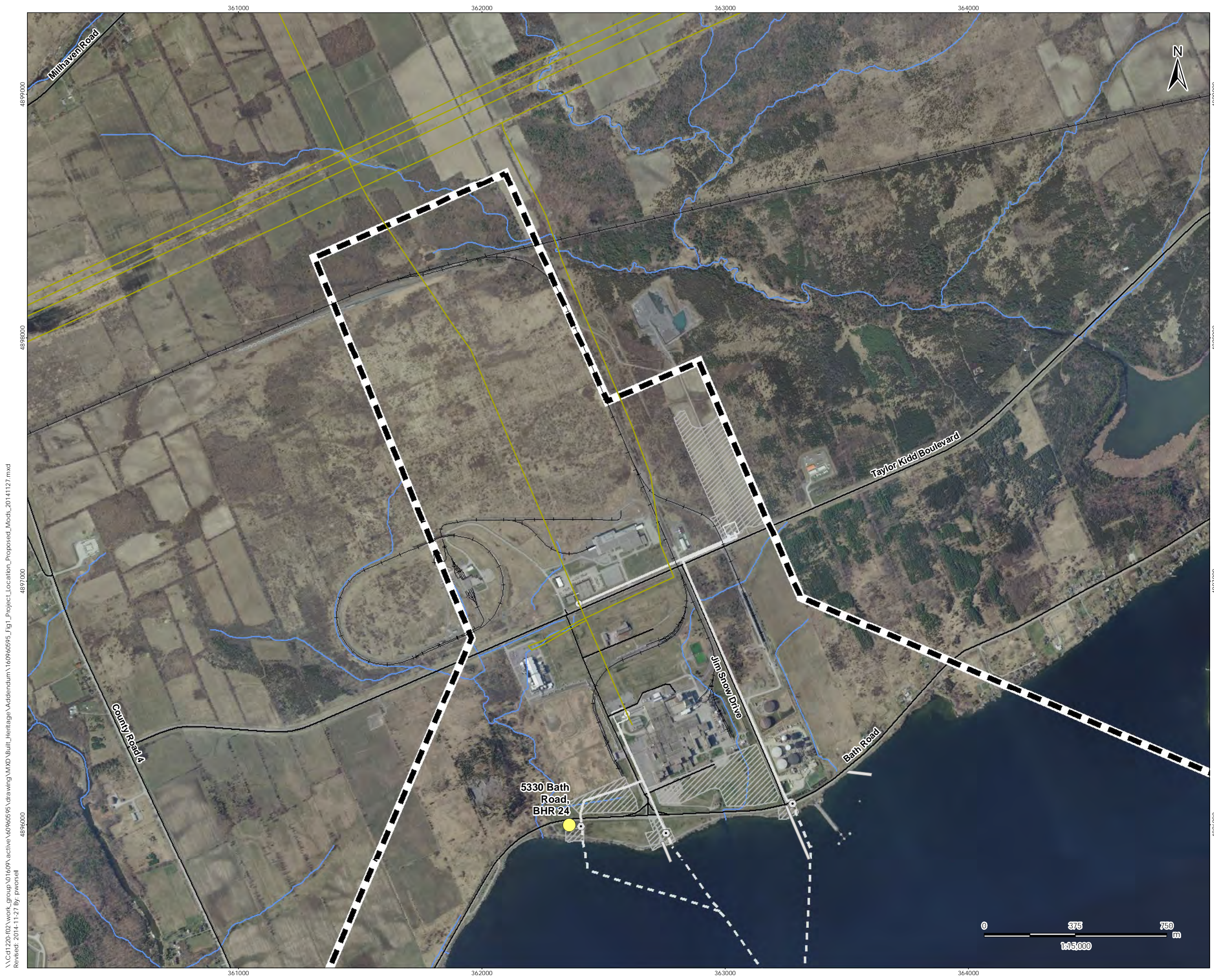

Legend

- Study Area
- Built Heritage Resource
- Protected Property
- Cultural Heritage Landscape
- Stone Fence
- Project Components**
- ⊙ Turbine (No Changes Proposed)
- ⊘ Turbine (Removed)
- ⊙ Met Tower - Potential Location (No Changes Proposed)
- ⊘ Met Tower - Potential Location (Removed)
- Other Project Component (No Changes Proposed)
- Other Project Component (New)
- Other Project Component (Removed)
- Existing Features**
- Road
- Unopened Road Allowance
- + Railway
- Hydro Line
- Watercourse
- Property Line

- Notes
1. Coordinate System: NAD 1983 UTM Zone 18N
 2. Base features produced under license with the Ontario Ministry of Natural Resources © Queen's Printer for Ontario, 2014.
 3. Orthoimagery © First Base Solutions, 2014. Imagery taken in 2008.

November 2014
160960595

Client/Project
Windlectric Inc.
Amherst Island Wind Energy Project

Figure No.
1.1

Title
Project Location & Study Area:
Proposed Modifications



\\Cd1220-102\work_group\01609\active\60960595\drawing\MXD\Built_Heritage\Addendum\160960595_Fig1_Project_Location_Proposed_Mods_20141127.mxd
 Revised: 2014-11-27 By: p.worsell

Legend

- Study Area
- Built Heritage Resource
- Protected Property
- Cultural Heritage Landscape
- Stone Fence
- Project Components**
- Turbine (No Changes Proposed)
- Turbine (Removed)
- Met Tower - Potential Location (No Changes Proposed)
- Met Tower - Potential Location (Removed)
- Other Project Component (No Changes Proposed)
- Other Project Component (New)
- Other Project Component (Removed)
- Existing Features**
- Road
- Unopened Road Allowance
- Railway
- Hydro Line
- Watercourse
- Property Line

Notes

1. Coordinate System: NAD 1983 UTM Zone 18N
2. Base features produced under license with the Ontario Ministry of Natural Resources © Queen's Printer for Ontario, 2014.
3. Orthoimagery © First Base Solutions, 2014. Imagery taken in 2008.

November 2014
160960595

Client/Project

Windlectric Inc.
Amherst Island Wind Energy Project

Figure No.

1.2

Title

Project Location & Study Area:
Proposed Modifications



\\C:\1220-102\work_group\01609\active\60960595\drawing\MXD\Built_Heritage\Addendum\160960595_Fig_1_Project_Location_Proposed_Mods_20141127.mxd
 Revised: 2014-11-27 By: pworsell

366000 367000 368000 369000 370000



Legend

- Study Area
- Built Heritage Resource
- Protected Property
- Cultural Heritage Landscape
- Stone Fence
- Project Components
 - Turbine (No Changes Proposed)
 - Turbine (Removed)
 - Met Tower - Potential Location (No Changes Proposed)
 - Met Tower - Potential Location (Removed)
 - Other Project Component (No Changes Proposed)
 - Other Project Component (New)
 - Other Project Component (Removed)
- Existing Features
 - Road
 - Unopened Road Allowance
 - Railway
 - Hydro Line
 - Watercourse
 - Property Line



- Notes
1. Coordinate System: NAD 1983 UTM Zone 18N
 2. Base features produced under license with the Ontario Ministry of Natural Resources © Queen's Printer for Ontario, 2014.
 3. Orthoimagery © First Base Solutions, 2014. Imagery taken in 2008.

November 2014
160960595

Client/Project
Windlectric Inc.
Amherst Island Wind Energy Project

Figure No.
1.3

Title
Project Location & Study Area:
Proposed Modifications



366000 367000 368000 369000 370000

\\C:\1220-102\work_group\01609\active\60960595\drawing\MXD\Built_Heritage\Addendum\160960595_Fig1_Project_Location_Proposed_Mods_20141117.mxd
Revised: 2014-11-27 By: p.worsell

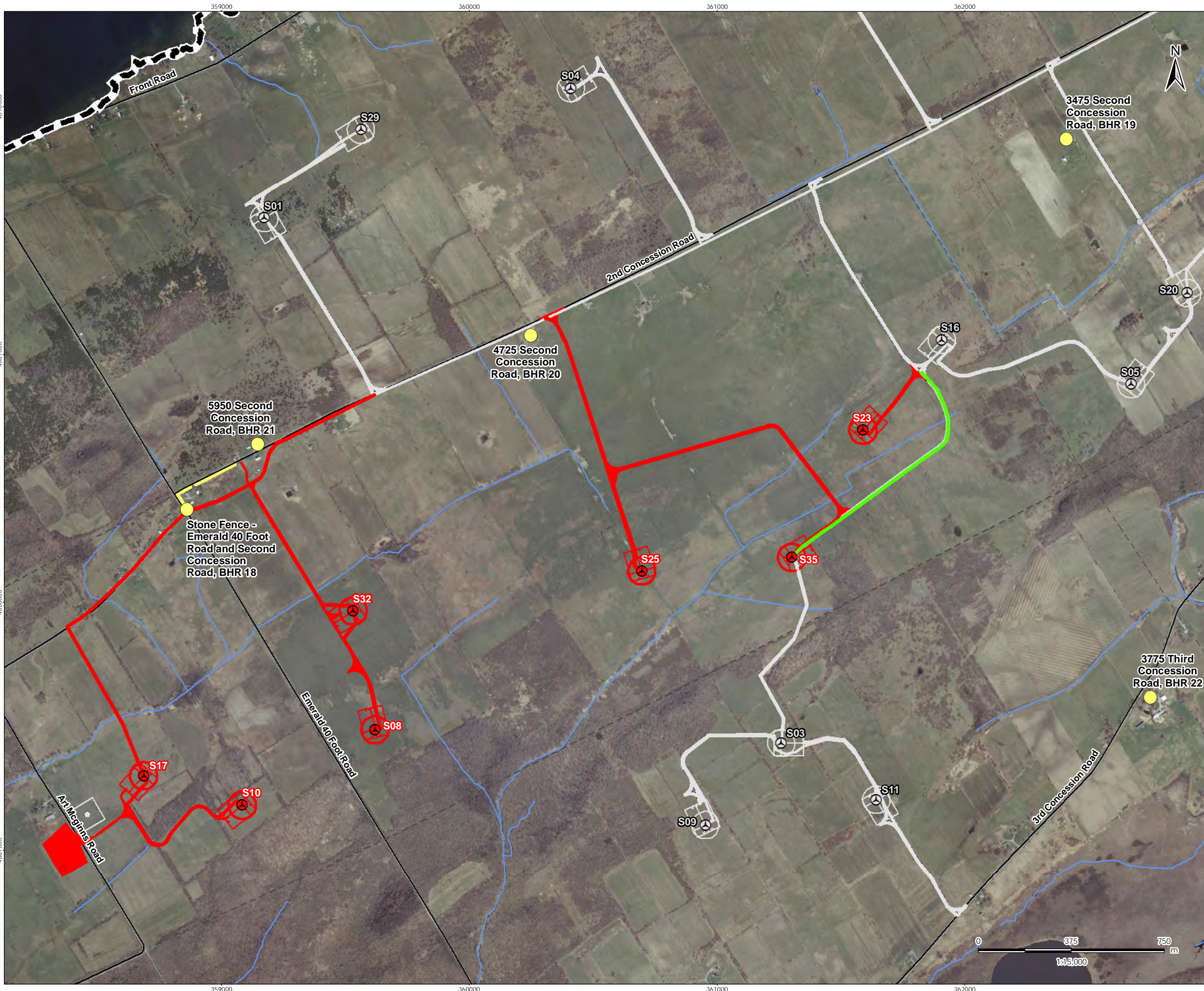

Legend

- Study Area
- Built Heritage Resource
- Protected Property
- Cultural Heritage Landscape
- Stone Fence

Project Components

- Turbine (No Changes Proposed)
- Turbine (Removed)
- Met Tower - Potential Location (No Changes Proposed)
- Met Tower - Potential Location (Removed)
- Other Project Component (No Changes Proposed)
- Other Project Component (New)
- Other Project Component (Removed)

Existing Features

- Road
- Unopened Road Allowance
- Railway
- Hydro Line
- Watercourse
- Property Line

Notes

1. Coordinate System: NAD 1983 UTM Zone 18N
2. Base features produced under license with the Ontario Ministry of Natural Resources © Queen's Printer for Ontario, 2014.
3. Orthoimagery © First Base Solutions, 2014. Imagery taken in 2008.

November 2014
160960595

Client/Project
Windlectric Inc.
Amherst Island Wind Energy Project

Figure No.
1.4

Title
Project Location & Study Area:
Proposed Modifications

\\C:\1220-102\work_group\01609\active\60960595\drawing\MXD\Built_Heritage\Addendum\160960595_Fig1_Project_Location_Proposed_Mods_20141127.mxd
 Revised: 2014-11-27 By: p.worsell



Legend

- Study Area
- Built Heritage Resource
- Protected Property
- Cultural Heritage Landscape
- Stone Fence
- Project Components**
- T Turbine (No Changes Proposed)
- T Turbine (Removed)
- T Met Tower - Potential Location (No Changes Proposed)
- T Met Tower - Potential Location (Removed)
- Other Project Component (No Changes Proposed)
- Other Project Component (New)
- Other Project Component (Removed)
- Existing Features**
- Road
- Unopened Road Allowance
- + Railway
- Hydro Line
- Watercourse
- + Property Line

Notes

1. Coordinate System: NAD 1983 UTM Zone 18N
2. Base features produced under license with the Ontario Ministry of Natural Resources © Queen's Printer for Ontario, 2014.
3. Orthoimagery © First Base Solutions, 2014. Imagery taken in 2008.

November 2014
160960595

Client/Project

Windlectric Inc.
Amherst Island Wind Energy Project

Figure No.

1.5

Title

Project Location & Study Area:
Proposed Modifications

\\Cd1220-102\work_group\01609\active\60960595\Addendum\Addendum\MXD\Built_Heritage\Addendum\Addendum\Proposed_Mods_20141117.mxd
 Revised: 2014-11-27 By: pwnorsell
 4887000

Skillen, Kerrie

From: Skillen, Kerrie
Sent: Wednesday, May 06, 2015 3:50 PM
To: Skillen, Kerrie
Subject: FW: Amherst Island Wind Energy Project Heritage Assessment and Protected Properties - Project Layout Modifications
Attachments: REA-MTCScomments-Amherst Island Wind 2014-12-19.pdf

From: Hatcher, Laura (MTCS) [<mailto:Laura.E.Hatcher@ontario.ca>]
Sent: Friday, December 19, 2014 5:31 PM
To: Rivard, Meaghan
Cc: sean.fairfield@algonquinpower.com; Garcia-Wright, Agatha (MOECC); Paul, Sarah (MOECC); Kulpa, Paula (MTCS)
Subject: Amherst Island Wind Energy Project Heritage Assessment and Protected Properties - Project Layout Modifications

Dear Meaghan,

The Ministry of Tourism, Culture and Sport has reviewed the addendum reports, submitted to MTCS on December 11, 2014, reflecting Project layout modifications to the Amherst Island Wind Energy Project.

For the addendum to the Protected Property report, the findings and recommendations of the report remain unchanged and the MTCS comment letter from April 5, 2013 remains valid.

For the addendum to the Heritage Assessment, please find attached a letter regarding the revised recommendations.

Sincerely,

Laura

Laura Hatcher, MCIP, RPP

Team Lead (A) – Heritage Land Use Planning

Culture Services Unit | Programs and Services Branch | Ministry of Tourism, Culture and Sport

401 Bay Street Suite 1700 Toronto ON M7A 0A7

Tel. 416.314.3108 | email: laura.e.hatcher@ontario.ca

**Ministry of Tourism, Culture
and Sport**

Culture Services Unit
Programs and Services Branch
Culture Division
401 Bay Street, Suite 1700
Toronto ON M7A 0A7
Tel: 416 314-7620
Fax: 416 212-1802

**Ministère du Tourisme, de la Culture
et du Sport**

Unité des services culturels
Direction des programmes et des services
Division de culture
401, rue Bay, bureau 1700
Toronto ON M7A 0A7
Tél: 416 314-7620
Télé: 416 212-1802



December 19, 2014

Ms. Meaghan Rivard
Heritage Consultant
Stantec
49 Frederick Street
Kitchener ON
N2H 6M7

Project:	Amherst Island Wind Energy Project
OPA Reference Number:	F-004563-WIN-130-601
Report Title:	Addendum to Heritage Assessment - Project Layout Modifications
Applicant:	Windlectric Inc.
Location:	Amherst Island, Township of Loyalist, County of Lennox and Addington
MTCS File No.:	16EA025

Dear Ms. Rivard:

This office has reviewed the above-mentioned addendum to the heritage assessment report (the "Addendum"), which has been submitted to this ministry as required under O. Reg. 359/09, as amended (Renewable Energy Approvals under the *Environmental Protection Act*) (the "REA regulation") to address changes to the project layout. This letter constitutes the Ministry of Tourism, Culture and Sport (the "Ministry") comments for the purposes of section 23(3)(a) of the REA regulation regarding the heritage assessment undertaken for the above project, and replaces our previous comment letter from April 17, 2013.

The Addendum recommends the following:

RECOMMENDATIONS

Based on these findings, it was determined the recommendations contained within the *Heritage Assessment* should be modified to reflect areas where additional assessment was undertaken as well as those where recommendations are no longer valid. We ask that the MTCS review the attached figures illustrating the proposed Project modification as well as the impact assessment contained within this letter. Following review, if appropriate, we request revision of the confirmation letter received by Stantec on April 17, 2013, to incorporate the revised recommendations as follows:

BHR/CHL #	Address/Name	Recommended Mitigation
BHR 3 BHR 4 BHR 5 BHR 6 BHR 19	2400 South Shore Road 3500 South Shore Road 4125 South Shore Road 2750 Front Road 3475 Second Concession Road	<ul style="list-style-type: none"> • Avoid Project activities within a 50 m bufferzone of structures on the property. • In the event that Project activities within a 50 m bufferzone cannot be avoided, it is recommended that maximum acceptable vibration, or peak particle velocity (PPV), levels be determined by a qualified engineer prior to Project activities and that activities be monitored to ensure that maximum PPV levels are not exceeded. • All Project activities should cease if levels are exceeded until a solution can be determined.
CHL 4	Ferry Landscape	<ul style="list-style-type: none"> • Documentation of ferry landscape prior to the construction of permanent and temporary Project infrastructure.
CHL 1 CHL 3	Village of Stella St. Paul's Presbyterian Church	<ul style="list-style-type: none"> • Avoid Project activities within a 50 m bufferzone of any structures in the CHL. • In the event that Project activities within a 50 m bufferzone cannot be avoided, it is recommended that maximum acceptable vibration, or peak particle velocity (PPV), levels be determined by a qualified engineer prior to Project activities and that activities be monitored to ensure that maximum PPV levels are not exceeded. • Photographically record condition of burial vault and monitor its physical condition during construction process. • All Project activities should cease if levels are exceeded until a solution can be determined.

In order to lessen or avoid potential indirect negative impacts from construction vibrations on BHRs 4, 5, 6, and 19 and components of CHLs 1 and 3, the following recommendations have been made:

- Project activities should be avoided within 50m of identified BHRs and any structures or buildings within identified CHLs.
- If Project activities within a 50 m bufferzone cannot be avoided, maximum acceptable vibration levels, or peak particle velocity (PPV) levels, should be determined by a qualified engineer with previous experience working with built heritage resources under similar circumstances.
- Project activities within the 50 m bufferzone should be monitored to ensure that PPV levels are not exceeded.
- All Project activities should cease immediately if levels are exceeded until a solution can be determined.

With respect to the dry stone walls associated with BHRs 7 and 18, while potential impacts are not anticipated, the following recommendations have been made and should be applied to previously identified resources as well as those encountered during Project construction activities:

- It is recommended that Project activities be avoided within a 50 m bufferzone of any dry stone walls.
- In the event that Project activities cannot be avoided within 50 m of any dry stone wall, the wall should be documented prior to the commencement of said activities.
- The stone wall should be assessed periodically by a qualified individual during Project activities to ensure that no damage is occurring.
- Project activities should cease immediately if vibrations are found to be resulting in damage until the wall can be adequately reinforced or supported.
- The stone wall should be evaluated by a qualified mason or engineer following Project activities to ensure that no damage has occurred and any damage to the wall should be repaired immediately following Project activities.

Finally, prior to construction of shoreline Project infrastructure, views from the Ferry Landscape should be more thoroughly documented, particularly towards the proposed locations of new permanent and temporary infrastructure. This documentation should include, at the very least, a photographic record of existing conditions and views.

Based on the information contained in the Addendum and the heritage assessment report, the Ministry is satisfied that the heritage assessment process and reporting are consistent with the applicable heritage assessment requirements established in s. 23 of O. Reg. 359/09. Please note that the Ministry makes no representation or warranty as to the completeness, accuracy or quality of the heritage assessment report (please see Note 1).

This letter does not waive any requirements under the *Ontario Heritage Act*.

This letter does not constitute approval of the renewable energy project. Approvals or licences for the project may be required under other statutes and regulations. Please ensure that you obtain all required approvals and/or licences.

Please ensure that the proponent is aware that, if new information or substantive project changes arise after issuance of this letter, the applicant should discuss them with you to determine if any additional assessment or reporting is required. If additional reporting or revisions are required, they should be submitted to the Ministry for review. Upon completion of that review, the Ministry will determine if any revisions to the content of this letter are required.

Should you have any questions or require further information, please do not hesitate to contact me.

Sincerely,

Laura Hatcher

Team Lead (A) – Heritage Land Use Planning

416-314-3108

laura.e.hatcher@ontario.ca

cc. Sean Fairfield, Senior Project Manager
Algonquin Power

Agatha Garcia-Wright, Director
Environmental Approvals Access & Service Integration Branch, Ministry of the Environment

Sarah Paul, Director
Environmental Approvals Branch, Ministry of the Environment

Paula Kulpa, Manager (A)
Culture Services Unit, Ministry of Tourism, Culture and Sport

Note 1: In no way will the Ministry be liable for any harm, damages, costs, expenses, losses, claims or actions that may result: (a) if the Report or its recommendations are discovered to be inaccurate, incomplete, misleading or fraudulent; or (b) from the issuance of this letter. Further measures may need to be taken in the event that additional heritage resources are identified or the Report is otherwise found to be inaccurate, incomplete, misleading or fraudulent.

Appendix F:
Noise Assessment Report



Windlectric Inc.

Noise Assessment Report

For

Amherst Island Wind Project

H340642-0000-07-124-0002

Rev. 14

May 4, 2015

Windlectric Inc.

Noise Assessment Report

For

Amherst Island Wind Project

H340642-0000-07-124-0002

Rev. 14

May 4, 2015



Project Report

May 4, 2015

Windlectric Inc.
Amherst Island Wind Project

Noise Assessment Report

Hatch

Prepared by:

Oleg Belashov, M.A.Sc., P.Eng.
e-mail: obelashov@hatch.ca
Tel: 905-374-0701 x 5269

May 4, 2015

Date

Approved by:



Mervyn Choy, P.Eng.
e-mail: mchoy@hatch.ca
Tel: 905-403-4200, Ext 3562

May 4, 2015

Date

Windlectric Inc.

Approved by:

Alex Tsopelas
e-mail: Alex.Tsopelas@algonquinpower.com

May 4, 2015

Date



Safety • Quality • Sustainability • Innovation

Table of Contents

1. Introduction.....	1
2. Project General Description	2
2.1 Site Location	2
2.2 Acoustical Environment	2
2.3 Approach to the Study	2
3. Noise Sources.....	4
3.1 Substation Transformer	4
3.2 Unit Transformers	4
3.3 Switching Station	4
3.4 Wind Turbine Generators	4
3.4.1 Adjustment to Wind Turbine Generator Acoustic Emissions for Wind Speed Profile	5
3.5 Adjacent Wind Farms	6
4. Noise Receptors and Points of Reception.....	7
5. Mitigation Measures	8
6. Noise Impact Assessment	9
6.1 Compliance with Performance Limits	9
7. Conclusions and Recommendations	10
8. References	11

List of Tables

Table 3.1	Basic Characteristics of Siemens SWT-2.942-113 and SWT-2.772-113 WTG Models	5
Table 6.1	Sound Pressure Limits for Class 3 Areas	9

List of Figures

Figure 2.1	CADNA-A Configurations.....	3
-------------------	------------------------------------	----------

Appendix A	Geographic Location of Project Study Area, Wind Farm Layout, Land Use Schedule
Appendix B	Noise Sources
Appendix C	Sound Pressure Levels for Points of Reception, Noise Maps from CADNA-A
Appendix D	CADNA-A Calculations and Verification

Noise Assessment Report Revision Summary

Rev. #	Summary
5	The Noise Assessment Report dated March 22, 2013 (Revision 4) has been revised to address MOE comments submitted by Kristina Rudzki. The following changes were made: <ul style="list-style-type: none"> Table B.5 Wind Turbine Generator Sound Power Level Adjustment was added in Appendix B.
6	The Noise Assessment Report dated September 5, 2013 (Revision 5) has been revised to address MOE comments submitted by Mahdi Zangeneh. The following changes were made: <ul style="list-style-type: none"> Figure A.1 was modified to provide a better view of the receptor congested areas where receptor IDs were obscured. The figure size was increased to A0. Sound power values in Table B.5 were converted from dBA to dB units. Figure C.3 showing noise contours and WTG proximity at noise receptor R557 was added.
7	The Noise Assessment Report dated June 2, 2014 (Revision 6) has been revised to address the addition of a "hunting shack/bunkie" as an existing receptor with the ID R727. The following changes were made: <ul style="list-style-type: none"> Updated Table B.1 to reflect change of WTG model for S07, S18, S26 from SWT-2.3-113 to the SWT 2.221-113 Table C.1 updated to reflect addition of existing non-participant receptor R727 and change of WTG model for S07, S18, and S26. Table C.2 updated to reflect change of WTG model for S07, S18, and S26 Figures A.1, and A.2 updated to include receptor R727 Figures C.1, C.2, and C.3 were updated to include receptor R727 and reflect the noise contours based on change of WTG model for S07, S18, and S26 Appendix B – Updated Contract Acoustic Emissions documents and added additional documents detailed below as provided by Siemens: <ul style="list-style-type: none"> Summary SWT-2.3-113 Rev 1 P6.024.13 Test Report Summary Amherst Island MOE Acoustic Letter from Siemens
8	Administrative changes only.
9	The Noise Assessment Report Rev 8 was revised to address the following changes: <ul style="list-style-type: none"> Receptors R027 and R505 were changed from 'Vacant' to 'Existing' and relocated. Receptors R728 (garage guest house), R729 (house), R730 (boathouse) and R731 (trailer) were added to the model, all non-participant. <p>Figures A.1, A.2, C.1 and C.2 were re-sized to A0 and insets were included to better show areas with high receptor density.</p>
10	Added Figure A.3 showing potential locations for switching station on the mainland, corrected error in noise model parameter that affected results of Rev. 9 only, updated Tables C.1 and C.2 and Figure C.2 as a result.
11	The total number of turbine locations was reduced by 9 to 27 from 36. Change in turbine models to SWT-2.942-113 at 13 locations and to SWT-2.772-113 at 14 locations. All figures and tables have been updated accordingly. Figure C.3 has been removed from the report as turbine S06 has been removed from the layout.
12	Administrative changes. Appendix B - Added SWT-3.2-113 IEC 2A Technical Specifications Rev 4 as provided by Siemens.
13	Siemens provided updated sound power spectra for the SWT-2.772-113 and SWT-2.942-113 WTG models. The study was updated to reflect the new sound power levels.
14	Units of sound power values in Table B.5 were changed from dBA to dB. The total capacity of the project after one turbine removal was changed from 75 MW to 74.3 MW.

REPORT DISCLAIMER

This report has been prepared by Hatch for the sole and exclusive use of Windlectric Inc. (Proponent), for the purpose of assisting the management of the Client in making decisions with respect to the potential development of the Amherst Island Wind Project, and for attachment to their application for a Renewable Energy Approval from the Ontario Ministry of the Environment and Climate Change (MOECC) and shall not be (a) used for any other purpose, or (b) provided to, relied upon or used by any third party.

This report contains opinions, conclusions and recommendations made by Hatch, using its professional judgment and reasonable care. Use of or reliance upon this report by Client is subject to the following conditions:

- (a) the report being read in the context of and subject to the terms of the agreement between Hatch and the Client dated January 20, 2012 (the "Agreement"), including any methodologies, procedures, techniques, assumptions and other relevant terms or conditions that were specified or agreed therein;
- (b) the report being read as a whole, with sections or parts hereof read or relied upon in context;
- (c) the conditions of the site may change over time or may have already changed due to natural forces or human intervention, and Hatch takes no responsibility for the impact that such changes may have on the accuracy or validity of the observations, conclusions and recommendations set out in this report; and

the report is based on information made available to Hatch by the Client or by certain third parties (Siemens, Land Information Ontario, First Base Solutions), including publicly available information; and unless stated otherwise in the Agreement, Hatch has not verified the accuracy, completeness or validity of such information, makes no representation regarding its accuracy and hereby disclaims any liability in connection therewith.

1. Introduction

This report presents the results of the noise assessment study required for Wind Farms under Ontario Regulation 359/09 [1] and its amendment Ontario Regulation 521/10 [2], as part of the Renewable Energy Approval (“REA”) Process.

Windlectric Inc. (hereinafter referred to as the “Proponent”) is proposing to develop the Amherst Island Wind Project, an approximately 75-MW wind energy project (the “Project”). The Project will be located on Amherst Island, within Loyalist Township in the County of Lennox and Addington, Ontario about 11 km southwest of Kingston.

A total of 28 sound sources were included in this study. Thirteen (13) Siemens SWT-2.942-113, fourteen (14) SWT-2.772-113 wind turbine generators (WTGs), and one 34.5-kV/115-kV/85-MVA substation transformer were evaluated for noise compliance, in an area extending approximately 14 km by 5 km. It should be emphasized that the Project capacity of 77 MW evaluated for noise impact will be reduced to 74.3 MW or less and only twenty six (26) wind turbine generators will be installed. Removal of one (1) WTG will further reduce the overall noise impact from the Project.

The report was prepared according to the publication entitled “Noise Guidelines for Wind Farms” [3] by the Ministry of the Environment (2008) and includes a general description of the Project, noise sources, noise receptors, assessment of compliance, and all supporting information relevant to the Project.

2. Project General Description

It is intended to permit 27 locations for thirteen (13) Siemens SWT-2.942-113, fourteen (14) SWT-2.772-113 wind turbine generators (for a total capacity of 77 MW), and one 34.5-kV/115-kV/85-MVA substation transformer, for a total of 28 noise sources. Basic characteristics of the proposed WTG models are available in Table 3.1.

The 34.5-kV power from the WTGs will be transmitted to the substation where it will be stepped up to 115 kV by a 34.5-kV/115-kV/85-MVA transformer.

The Project is considered to be a Class 4 Wind Facility, according to the classification presented in Ontario Regulation 359/09.

2.1 Site Location

The Project will be located on Amherst Island, within Loyalist Township in the County of Lennox and Addington, Ontario. The Project Area, extending 14 km by 5 km, is situated about 11 km southwest of Kingston on land, most of which is zoned as prime agricultural, and the rest as rural. Figure A.1 in Appendix A shows the geographical location of the Project along with topographical features. The detailed Land Use Schedule obtained from Loyalist Township, is available in Figure A.2 of Appendix A.

2.2 Acoustical Environment

The Project WTGs will be situated on private land on the island. There are no major industrial facilities on the island; however a number of large manufacturing facilities, such as Lafarge cement plant and Lennox generating station, are located on the mainland along the shore opposite to the Project Area. Noise emitted by these facilities can be heard along the island north shore during day and night time. The Frontenac II, a vessel used to transport people and goods from the mainland to the island, is a significant background noise contributor near the town of Stella. Stella, the largest populated center on the island, is located in the middle of the northern side of the Project. Most of the noise receptors on the island are located along its shoreline.

2.3 Approach to the Study

The sound pressure levels at the Points of Reception (POR) used to model the noise receptors were predicted using procedures from ISO 9613-2, which is a widely used standard for evaluation of noise impact in environmental assessments referenced in the Noise Guidelines for Wind Farms document [3].

The sound power levels for the WTGs were provided by Siemens, and are included in Appendix B. This information is presented as frequency spectra from 63 Hz to 8,000 Hz, for wind speeds from 6 to 10 m/s.

At this stage of project design, the transformer manufacturer has not been selected. Thus, the sound power level was estimated based on the National Electrical Manufacturers Association (NEMA) standard, which represents a worst-case scenario (highest sound emissions) for the transformers.

The software package CADNA-A, which implements ISO 9613-2 standard recommended by the MOECC in Reference [3], was used to predict the noise levels at the POR. Some of the

CADNA-A configurations recommended by the MOECC that were used in the modeling are shown in Figure 2.1, with more details available in Appendix D. The height contours for the area were taken from the Ontario Base Maps (“OBM”). Any obstacle, (ground surface or physical barrier) that did not break the source-POR line of site was not taken into account as attenuation contribution (no negative path difference).

For modelling purposes, the vegetation and other obstacles (such as barns) that block some of the POR from the sources have not been incorporated. Exclusion of these obstacles from the model results in more conservative sound pressure levels predicted at the POR. In reality, these obstacles may help reduce noise impact at the POR.

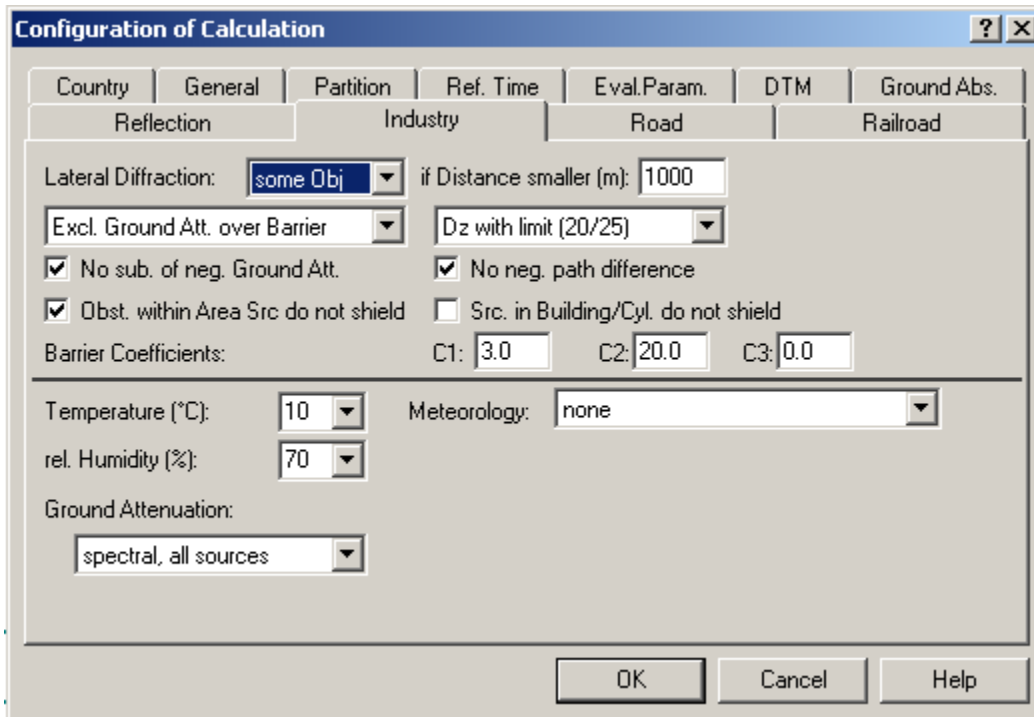

Figure 2.1 CADNA-A Configurations

3. Noise Sources

A total of 27 WTGs and one substation transformer were evaluated in this study. Table B.1 and Table B.2 in Appendix B present the coordinates of each source included in the model. The sound power levels of the sources are listed in Table B.6.

3.1 Substation Transformer

The Proponent will have one substation containing one 34.5-kV/115-kV/85-MVA transformer as part of the Project. The 34.5-kV electrical power generated by the WTGs will be stepped up to 115-kV by the transformer.

Since the transformer make and model have not been selected at this point, although it is known that the transformer will be of ONAF (oil natural air forced) type, a conservative estimate of sound power level was based on the data from NEMA TRI – 1993 (2000) with a reference sound-producing surface area of 62.9-m². This standard provides the maximum sound level values for transformers, and manufacturers routinely meet this specification. The results, based on NEMA, will slightly overestimate the impact on the POR since the actual transformer to be procured for the project will be below the NEMA specified sound levels.

The NEMA levels were converted into frequency spectra using empirical correlations for transformer noise [4]. This calculation is available in Figure B.1 of Appendix B. The basic transformer dimensions are expected to be similar to those shown in Figure B.2. The noise source height representing the transformer was assumed at 4.0 m above ground level.

Power transformers are considered by the MOECC to be tonal noise sources. A 5-dB penalty was added to the sound power spectrum, as recommended by Publication NPC-104, "Sound Level Adjustments" for tonality [8]. Table B.6 in Appendix B shows the frequency spectrum used to model the substation transformer.

The Proponent is committed to installing a transformer that will emit the same, or lower, noise levels than the one modeled.

3.2 Unit Transformers

Each WTG has a 34.5-kV unit transformer located outside of the tower right beside the tower base. These transformers are not considered significant noise sources relative to WTGs, as stated by the Guidelines for Wind Farms document [3].

3.3 Switching Station

The project includes a switching station to be located outside of the island. Figure A.3 in Appendix A shows the two potential locations for the switching station. The electrical hardware used in the station is not considered to be a significant noise source.

3.4 Wind Turbine Generators

The Proponent is planning to permit a total of twenty seven (27) locations, where thirteen (13) Siemens SWT-2.942-113 and fourteen (14) Siemens SWT-2.772-113 wind turbine generators are modelled. The basic characteristics of the SWT-2.942-113 and SWT-2.772-113 models are presented in Table 3.1. More technical details on the WTGs, including acoustical data provided

by Siemens, can be found in Appendix B. WTG coordinates are presented in Table B.1 while sound power level spectra used in the modeling are available in Table B.6. According to the manufacturer and Reference [3], wind turbines do not present any tonality issues; therefore no tonality penalty was added to the sound power spectrum.

Table 3.1 Basic Characteristics of Siemens SWT-2.942-113 and SWT-2.772-113 WTG Models

	SWT-2.942-113	SWT-2.772-113
Official model name as provided by Siemens*	SWT-3.2-113 2A, Rev.0, Max. Power 2942 kW	SWT-3.2-113 2A, Rev.0, Max. Power 2772 kW
Type	3-bladed, horizontal axis	3-bladed, horizontal axis
Hub height	99.5 m	99.5 m
Nominal capacity	2.942 MW	2.772 MW
Total maximum sound power	105.0 dBA	104.0 dBA
Rotor diameter	113 m	113 m
Swept area	10,000 m ²	10,000 m ²
Blade length	55 m	55 m
Rotor chord	4.2 m	4.2 m
Rotor tilt	6 deg	6 deg
Rotor speed range	6–13 rpm	6–13 rpm
Cut-in wind speed	11 km/h (3 m/s)	11 km/h (3 m/s)
Nominal wind speed	45 km/h (12.5 m/s)	45 km/h (12.5 m/s)
Cut-out wind speed	90 km/h (25 m/s)	90 km/h (25 m/s)

* SWT-3.2-113 2A, Rev.0, Max. Power 2942 kW” model has been referred in the report as SWT-2.942-113 and “SWT-3.2-113 2A, Rev.0, Max. Power 2772 kW” model has been referred in the report as SWT-2.772-113.

3.4.1 Adjustment to Wind Turbine Generator Acoustic Emissions for Wind Speed Profile

Following the Noise Guidelines for Wind Farms (2008), the wind shear for summer nights (June 21 to September 20, 11 p.m. to 7 a.m.) was calculated based on direct wind measurements from the meteorological masts existing on the island, and was determined to be 0.45 as reported in Table B.5. The adjustment is not shown on Table B.5 for the following reasons:

1. Using the adjustment process would have resulted in the assessment being completed using the highest wind speed sound data provided by the manufacturer which would not have been the worst case (note that all wind speeds from 7-10 m/s have the same total sound power level).
2. An analysis of the various permutations of combinations of noise data for the two turbine models proposed was completed and determined that the 10 m/s sound data for both models resulted in the worst case predictions for the receptors, which is why the results of the report are based on this scenario.

The acoustical data provided by Siemens is available in Table B.5 and Table B.6. The acoustical data used in the analysis (Table B.6) is equivalent to the worst case scenario sound emissions reported by Siemens, which corresponds to the wind speed of 10 m/s for SWT-2.942-113 model and SWT-2.772-113 model. These noise emissions were tested in accordance with IEC 61400-11 and were calculated based on measurements from the SWT-2.942-113 and SWT-2.772-113 models.

3.5 Adjacent Wind Farms

The closest wind farms proposed in the vicinity of the Project are Ernestown and Dorland, both located on the mainland, north and northwest of the Project, respectively. The information regarding these adjacent wind projects was obtained from their official web sites <http://www.ernestownwind.com> and http://www.gileadpower.com/projects_eastern_dorland.htm.

Ernestown wind farm is a 10-MW project containing five WTGs. The shortest distance from the Ernestown WTGs to the Amherst Island Wind Project noise receptors is 5260 m.

Dorland wind farm is an 80-MW project for which no layout is publicly available. Since no data on the WTG locations can be presently obtained, the Dorland project site boundary, available at the web site, was used as a reference. It was determined that the closest Amherst Island Wind Project noise receptor is located at 5574 m from the Dorland project site boundary.

Following the Noise Guidelines for Wind Farms document [3], no noise contribution from the adjacent wind farms was taken into account since there are no adjacent WTGs at less than 5000 m from the Project noise receptors.

4. Noise Receptors and Points of Reception

The noise receptors modeled in the study were obtained using Ontario Base Maps, high-resolution satellite imagery, and data from site inspections. The Loyalist municipality was contacted for the approved building permits and all corresponding locations were considered as noise receptors. Also, the noise receptors corresponding to the vacant lots were added based on parcel information provided by First Base Solutions (Teranet Data - 2012) and located according to the requirements outlined in Ontario Regulation 359/09, and its amendment Ontario Regulation 521/10. All Noise Receptors within 1500 m of the project WTGs and 1000 m of the project substation transformer were assessed and included in the noise report.

The noise receptors were represented by points of reception (POR) in the CADNA model. Each noise receptor was modeled by two POR: one placed in the middle of the receptor footprint and elevated at 4.5 m above ground; and another one by a point located within 30-m distance from the receptor center where the sound pressure is maximum at 1.5-m above ground elevation.

The minimum distance between WTGs and non-participating noise receptors was kept above 550 m. The minimum distance from the existing participating noise receptors was kept at 400 m. No distance restrictions were applied for the participating vacant lot noise receptors. The distances were measured between the noise receptor footprint center and WTG tower center.

The total number of noise receptors located within 1500 m from any of the Project WTGs and within 1000 m from the Project substation is 369. As specified by the Noise Guidelines for Wind Farms, the noise receptors were classified as either participating or non-participating. Participating noise receptors correspond to land owners that have some Project related infrastructure on their property. Infrastructure includes wind turbine generators, substation, underground collector cables, access roads, operation and maintenance building, and storage building. For this Project, there are a total of 44 participating noise receptors. All other potential noise receptors (325) are considered non-participating for the purpose of verifying compliance with the MOECC guidelines.

Receptor R730, which was raised by its owner very late in the process, does not appear to be a “dwelling” as that term is used in Regulation 359/09. Windlectric has nevertheless agreed with the MOECC to include results for this location as an alternative to spending the additional time (and risking process delay) on a specific investigation of its features and has instructed Hatch to include this structure in this analysis.

5. Mitigation Measures

An acoustical barrier is required at the substation transformer in order to achieve noise compliance at the noise receptors located in the vicinity of the substation. The material for the barriers was assumed to be Durisol Richmond Panel manufactured by Armttec. Table B.3 in Appendix B presents absorption coefficients used in the CADNA-A model, while Figure B.2 shows details of the proposed barrier. The barrier will be continuous and its surface density will be 184 kg/m^2 , exceeding the 20-kg/m^2 requirement established by the MOECC. More information on the Durisol Richmond Panel can found in Appendix B. The Proponent is committed to using barrier material which will have equivalent or higher absorption coefficients than those used in the modeling.

Table B.4 lists UTM coordinates, height, and length of the substation barrier as it was modeled in CADNA-A.

6. Noise Impact Assessment

The purpose of the acoustic assessment report is to demonstrate that the Project is in compliance with the noise performance limits. All noise receptors considered in the study were assumed to be located in Class 3 areas as defined in Publication NPC-232 [9]. A Class 3 area means a rural area with an acoustical environment that is dominated by natural sounds having little or no traffic. Table 6.1 shows the performance limits set by the MOECC for Class 3 areas, according to Noise Guidelines for Wind Farms publication.

Table 6.1 Sound Pressure Limits for Class 3 Areas

Wind Speed at 10-m Height [m/s]	4	5	6	7	8	9	10
POR sound pressure limits (dBA)	40.0	40.0	40.0	43.0	45.0	49.0	51.0

For this study, the overall ground attenuation coefficient was assumed to be 0.7, as recommended by the MOECC for evaluating the noise impact of renewable energy facilities. The maximum sound pressure level specified at 6 m/s (40.0 dBA) was used as the compliance criterion for the POR representing the non-participating noise receptors.

As outlined by Section 6.7 of the Noise Guidelines for Wind Farms [3], a manual calculation was carried out to confirm the results obtained using CADNA-A for a single source-POR pair. For this Project, MathCAD was used as a calculating tool, and the source-POR pair selected was S11 and POR at 4.5 m representing R080 noise receptor. R080 is a non-participating noise receptor located 575 m from wind turbine generator S11. The MathCAD printout is included in Appendix D and confirms the results of the CADNA-A model. In addition, a sample calculation from the CADNA-A model for R080 is provided in Appendix D to demonstrate the outputs as well as the inputs placed into the CADNA-A software.

6.1 Compliance with Performance Limits

Table C.1 in Appendix C presents calculated sound pressure levels at the POR corresponding to non-participating noise receptors and it also lists distances to the nearest noise sources. Table C.2 lists results for the POR representing participating noise receptors. Figure C.1 displays sound pressure contours calculated at 4.5 m. Figure C.2, presented in A0 size, shows more detail regarding setback from wind turbines and property lines, along with the 40 dBA contour line (as per MOECC's request on August 28, 2013). Satellite imagery was not added for clarity of the other elements.

The findings of this study show that all non-participating noise receptors are compliant with MOECC guidelines based on the performance limit of 40 dBA and 550-m noise receptor-WTG distance.

7. Conclusions and Recommendations

For the Amherst Island Wind Project, the sound pressure levels at the noise receptors have been estimated using the CADNA-A model based on ISO 9613-2. The performance limits used for comparison correspond to Class 3 areas with 40.0-dBA limit.

Based on the results obtained in this study it is concluded that the sound pressure levels, resulting from the Amherst Island Wind Project operation based on 27 WTG locations and one substation transformer, at the noise receptors located within 1500 m from any of the Project wind turbine generators and within 1000 m from the Project substation will be compliant with the MOECC requirements for Class 3 areas of 40.0 dBA at all times.

It should be emphasized that the Project capacity of 77 MW evaluated for noise impact will be reduced to approximately 74.3 MW or less and only twenty six (26) wind turbine generators will be installed resulting in further reduction of the overall noise impact.

8. References

- [1]. Ontario Regulation 359/09; Environmental Protection Act; Renewable Energy Approvals under Part V.0.1 of the Act.
- [2]. Ontario Regulation 521/10 made under the Environmental Protection Act; Amending Ontario Regulation 359/09.
- [3]. Noise Guidelines for Wind Farms; Interpretation for Applying MOE NPC Publications to Wind Power Generation Facilities; Ministry of the Environment; October 2008.
- [4]. Robert D. Stevens; Chris Hung; Toward A Realistic Estimate of Octave Band Sound Levels for Electric Transformers
- [5]. NEMA; Standards Publication No. TR 1-1993 (R2000); Transformers, Regulators and Reactors; National Electrical Manufacturers Association.
- [6]. ISO 1996-1 Description; Measurement and Assessment of Environmental Noise – Part 1; Basic Quantities and Assessment Procedures.
- [7]. International Organization for Standardization (ISO). Standard 1913-2: Acoustics – Attenuation of sound during propagation outdoors – Part 2: General Method of Calculation
- [8]. NPC-104, “Sound Level Adjustments,” Ontario Ministry of the Environment
- [9]. MOE 1995; Sound Level Limits for Stationary Sources in Class 3 Areas (Rural); Publication NPC-232; Ontario Ministry of the Environment.
- [10]. MOE 1995; Sound Level Limits for Stationary Sources in Class 1 & 2 Areas (Urban); Publication NPC-205; Ontario Ministry of the Environment.

Appendix A

Geographic Location of Project Study Area, Wind Farm Layout, Land Use Schedule

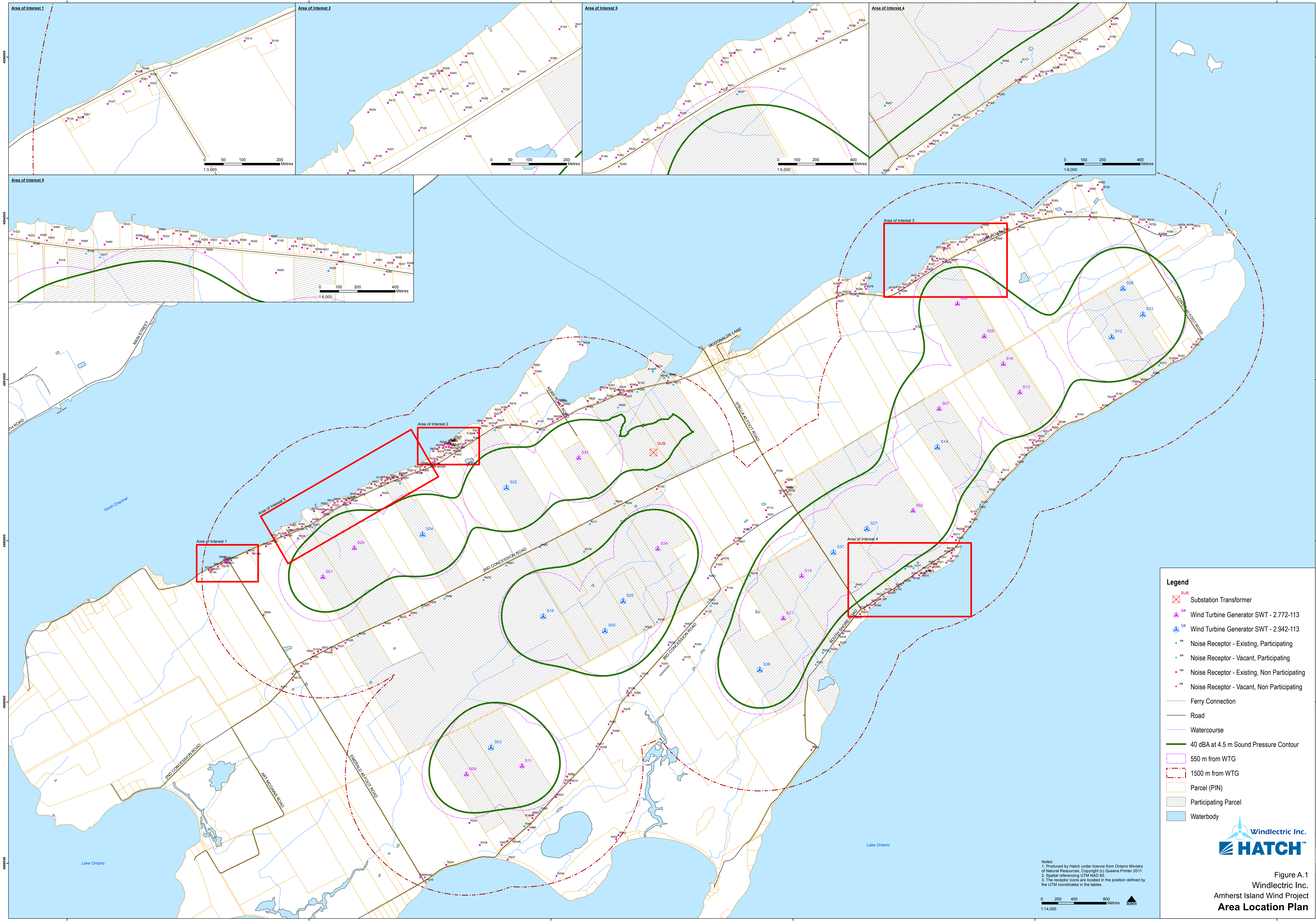

Legend

- Substation Transformer
- Wind Turbine Generator SWT - 2.772-113
- Wind Turbine Generator SWT - 2.942-113
- Noise Receptor - Existing, Participating
- Noise Receptor - Vacant, Participating
- Noise Receptor - Existing, Non Participating
- Noise Receptor - Vacant, Non Participating
- Ferry Connection
- Road
- Watercourse
- 40 dBA at 4.5 m Sound Pressure Contour
- 550 m from WTG
- 1500 m from WTG
- Parcel (PIN)
- Participating Parcel
- Waterbody

Notes:
 1. Produced by Hatch under licence from Ontario Ministry of Natural Resources, Copyright (c) Queens Printer 2011.
 2. Spatial referencing UTM NAD 83.
 3. The receptor icons are located in the position defined by the UTM coordinates in the tables.



Figure A.1
 Windelectric Inc.
 Amherst Island Wind Project
Area Location Plan

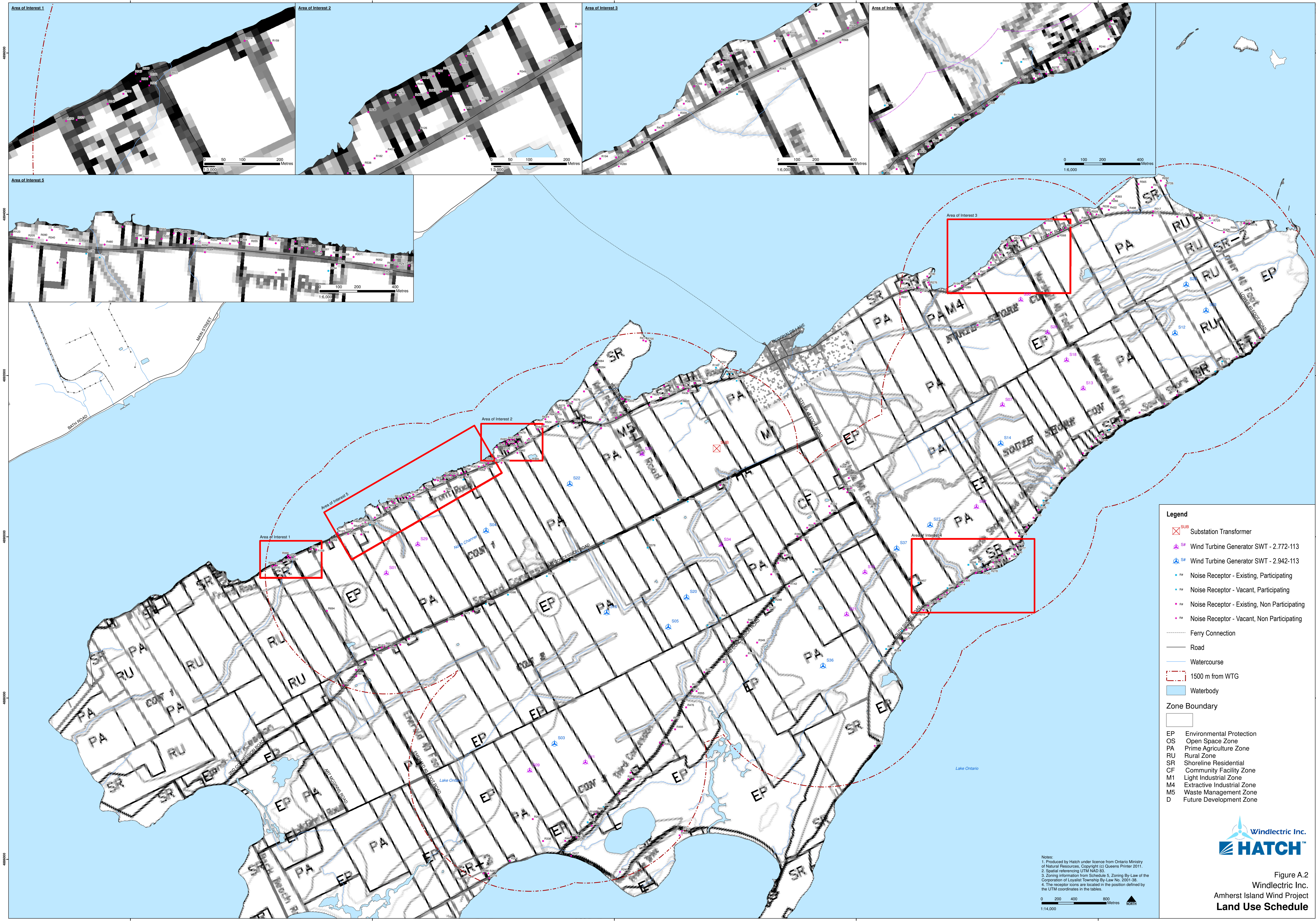

Legend

- ⊠ SUB Substation Transformer
- ⚡ SW Wind Turbine Generator SWT - 2.772-113
- ⚡ SW Wind Turbine Generator SWT - 2.942-113
- ⦿ NR Noise Receptor - Existing, Participating
- ⦿ NR Noise Receptor - Vacant, Participating
- ⦿ NR Noise Receptor - Existing, Non Participating
- ⦿ NR Noise Receptor - Vacant, Non Participating
- Ferry Connection
- Road
- Watercourse
- 1500 m from WTG
- Waterbody

Zone Boundary

- EP Environmental Protection
- OS Open Space Zone
- PA Prime Agriculture Zone
- RU Rural Zone
- SR Shoreline Residential
- CF Community Facility Zone
- M1 Light Industrial Zone
- M4 Extractive Industrial Zone
- M5 Waste Management Zone
- D Future Development Zone

Notes:
 1. Produced by Hatch under license from Ontario Ministry of Natural Resources, Copyright (c) Queens Printer 2011.
 2. Spatial referencing UTM NAD 83.
 3. Zoning information from Schedule 5, Zoning By-Law of the Corporation of Loyalist Township By-Law No. 2001-38.
 4. The receptor icons are located in the position defined by the UTM coordinates in the tables.

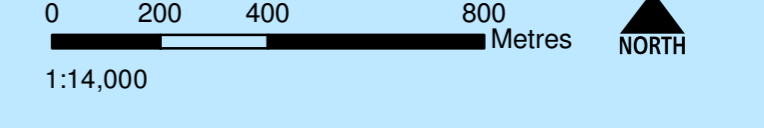
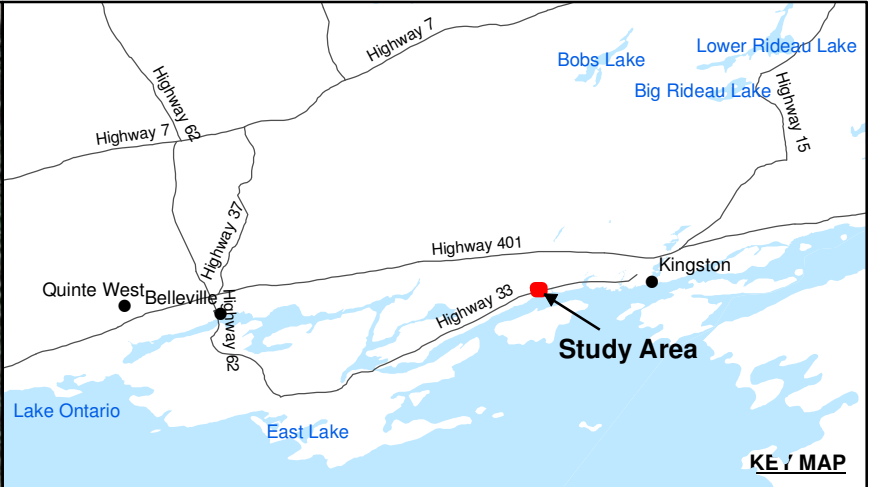

Figure A.2
 Windelectric Inc.
 Amherst Island Wind Project
 Land Use Schedule

362200 362400 362600 362800 363000 363200



Legend

- Road
- Watercourse
- Potential Switching Station

	Easting	Northing
A	362,565.4	4,896,448.9
B	363,023.0	4,897,213.4

Notes:
 1. Produced by Hatch under licence from Ontario Ministry of Natural Resources, Copyright (c) Queens Printer 2014.
 2. Spatial referencing UTM NAD 83, Zone 18.



Figure A.3
Windlectric Inc.
 Amherst Island Wind Project
Switching Station



Source: Esri, DigitalGlobe, GeoEye, Earthstar, USDA, USGS, AEX, Getmapping, Aerogrid, IGN, IGP, swisstopo, and the GIS User Community

Date Saved: 9/12/2014 5:30:07 PM

Path: P:\ALGONQU\340642\SPECIALIST_APPS\GIS\Map Documents\Layout\WindLayout_LayoutS20_SwitchingStation.mxd

H340642-1000-50-015-0014 Rev. 0

Appendix B

Noise Sources

Table B.1 Wind Turbine Generator List (27 WTGs)

ID	Equipment Make and Model	UTM NAD 83, Zone 18		Spectra ID	Total Sound Power [dBA]	Height [m]
		X[m]	Y[m]			
S01	Siemens SWT-2.772-113	359172	4889551	SWT_2772_113_10ms	104	99.5
S02	Siemens SWT-2.772-113	366489	4890373	SWT_2772_113_10ms	104	99.5
S03	Siemens SWT-2.942-113	361257	4887434	SWT_2942_113_10ms	105	99.5
S04	Siemens SWT-2.942-113	360408	4890076	SWT_2942_113_10ms	105	99.5
S05	Siemens SWT-2.942-113	362668	4888881	SWT_2942_113_10ms	105	99.5
S07	Siemens SWT-2.772-113	366812	4891637	SWT_2772_113_10ms	104	99.5
S09	Siemens SWT-2.772-113	360951	4887104	SWT_2772_113_10ms	104	99.5
S11	Siemens SWT-2.772-113	361641	4887206	SWT_2772_113_10ms	104	99.5
S12	Siemens SWT-2.942-113	368952	4892526	SWT_2942_113_10ms	105	99.5
S13	Siemens SWT-2.772-113	367813	4891841	SWT_2772_113_10ms	104	99.5
S14	Siemens SWT-2.942-113	366790	4891157	SWT_2942_113_10ms	105	99.5
S16	Siemens SWT-2.942-113	361904	4889060	SWT_2942_113_10ms	105	99.5
S18	Siemens SWT-2.772-113	367607	4892193	SWT_2772_113_10ms	104	99.5
S19	Siemens SWT-2.772-113	365107	4889563	SWT_2772_113_10ms	104	99.5
S20	Siemens SWT-2.942-113	362894	4889249	SWT_2942_113_10ms	105	99.5
S21	Siemens SWT-2.772-113	364881	4889039	SWT_2772_113_10ms	104	99.5
S22	Siemens SWT-2.942-113	361447	4890656	SWT_2942_113_10ms	105	99.5
S26	Siemens SWT-2.772-113	367371	4892536	SWT_2772_113_10ms	104	99.5
S27	Siemens SWT-2.942-113	365916	4890146	SWT_2942_113_10ms	105	99.5
S28	Siemens SWT-2.942-113	369091	4893127	SWT_2942_113_10ms	105	99.5
S29	Siemens SWT-2.772-113	359562	4889909	SWT_2772_113_10ms	104	99.5
S30	Siemens SWT-2.772-113	367040	4892941	SWT_2772_113_10ms	104	99.5
S31	Siemens SWT-2.772-113	362343	4891028	SWT_2772_113_10ms	104	99.5
S33	Siemens SWT-2.942-113	369337	4892806	SWT_2942_113_10ms	105	99.5
S34	Siemens SWT-2.772-113	363324	4889901	SWT_2772_113_10ms	104	99.5
S36	Siemens SWT-2.942-113	364589	4888397	SWT_2942_113_10ms	105	99.5
S37	Siemens SWT-2.942-113	365501	4889854	SWT_2942_113_10ms	105	99.5

Table B.2 Location of Substation Transformers
Sound power level includes a 5-dBA tonality penalty.

ID	Description	UTM NAD 83, Zone 18		Spectra ID	Total sound power [dBA]	Height [m]
		X[m]	Y[m]			
Sub	34.5-kV/115-kV/85-MVA substation transformer	363269.13	4891095.48	Tr_34.5kV_115kV_85MW	105.2	4.0

Table B.3 Absorption Coefficient Spectrum for Acoustical Barrier at the Substation Transformer

Material name	Spectra ID	Octave Spectrum									
		31.5	63	125	250	500	1000	2000	4000	8000	Aw
Durisol Richmond Panel	Durisol Richmond	0	0	0.29	0.53	0.97	0.87	0.89	0.90	0	0.8

Table B.4 Sound Barrier Coordinates

Barrier ID	Source ID	Absorption Spectra ID	UTM NAD 83, Zone 18		Length [m]	Height [m]
			X[m]	Y[m]		
Barrier_Sub	Sub	Durisol Richmond	363265.12	4891094.03	17.04	6.0
			363266.88	4891090.09		
			363274.64	4891093.56		
			363272.91	4891097.41		

Table B.5 Wind Turbine Generator Sound Power Level Adjustment

Make and Model		Siemens SWT-2.772-113								
Electrical Rating [kW]		2772								
Hub Height [m]		99.5								
Wind Shear Coefficient		0.45								
Octave Band Sound Power Level [dB]										
	Manufacturer's Emissions Levels					Adjusted Sound Power Level				
Wind Speed [m/s]	6	7	8	9	10	6	7	8	9	10
Frequency [Hz]										
63	116.0	117.2	117.5	117.4	117.7	117.7				
125	107.4	109.1	109.7	109.3	109.8	109.8				
250	103.5	103.4	102.9	103.6	103.8	103.8				
500	99.7	99.5	98.7	98.8	99.4	99.4				
1000	97.7	97.6	97.5	97.6	97.4	97.4				
2000	96.0	96.1	95.9	96.0	95.7	95.7				
4000	93.4	94.3	95.1	94.6	94.0	94.0				
8000	83.8	84.6	84.3	84.1	85.7	85.7				
Combined [dBA]	103.8	104.0	104.0	104.0	104.0	104.0				

Make and Model		Siemens SWT-2.942-113								
Electrical Rating [kW]		2942								
Hub Height [m]		99.5								
Wind Shear Coefficient		0.45								
Octave Band Sound Power Level [dB]										
	Manufacturer's Emissions Levels					Adjusted Sound Power Level				
Wind Speed [m/s]	6	7	8	9	10	6	7	8	9	10
Frequency [Hz]										
63	116.2	117.0	117.6	117.6	117.4	117.4				
125	108.9	109.0	109.5	110.0	109.8	109.8				
250	104.5	104.6	104.4	104.8	104.7	104.7				
500	100.7	100.8	100.3	99.9	100.5	100.5				
1000	98.6	98.8	98.5	98.2	98.9	98.9				
2000	96.9	97.2	97.8	97.9	97.3	97.3				
4000	94.3	95.3	95.0	94.9	94.8	94.8				
8000	84.5	85.2	85.2	84.9	83.1	83.1				
Combined [dBA]	104.7	105.0	105.0	105.0	105.0	105.0				

Table B.6 Sound Power Spectra Used for Modelling the Noise Sources

The WTG spectra are site adjusted.

The data does not include tonality penalties for the transformer.

Spectra ID	Description	Octave Spectrum [dBA]									
		31.5	63	125	250	500	1000	2000	4000	8000	Total
SWT_2772_113_10ms*	Provided by Siemens for SWT-2.772-113 model for 10 m/s wind speed		91.5	93.7	95.2	96.2	97.4	96.9	95.0	84.6	104.0
SWT_2942_113_10ms*	Provided by Siemens for SWT-2.942-113 model for 10 m/s wind speed		91.2	93.7	96.1	97.3	98.9	98.5	95.8	82.0	105.0
Tr_34.5kV_115kV_85MW	Estimated for 34.5 kV/115-kV/85-MW transformer using sound levels from NEMA TR 1-1993 (R2000) and empirical equations from Stevens & Hung paper	55.6	72.8	85.9	91.4	96.8	94.0	90.2	85.0	74.9	100.2

* For both models (SWT-2.772-113 and SWT-2.942-113) different wind speeds and combinations were tested as per data provided by Siemens. The results show that the worst case scenario corresponds to the 10 m/s for both models.

Estimated Frequency Spectra for Transformers

Substation transformer - 34.5kV/115kV/85MVA - Oil filled

From Robert D. Stevens and Chris Hung, "Toward a realistic estimate of octave band sound levels for electrical transformers" paper

Average LpA	82.0 dBA	Based on NEMA TR1-1993 (R2000), Table 0-2, immersed power transformers
Ref. Sound Producing Surface Area:	62.9 m ²	Estimated based on similar transformer dimensions and similar methodology as described in IEEE C57.12.90-2010

Correction factors to be used with meters²

Freq. [Hz]	31	63	125	250	500	1000	2000	4000	8000
Correction [dB]	-5.0	-1.0	2.0	0.0	0.0	-6.0	-11.0	-16.0	-24.0

Sound Power Level calculated as $L_w = \text{Average LpA} + 10 \cdot \log(\text{Estimated surface area in m}^2) + C$

Freq. [Hz]	31	63	125	250	500	1000	2000	4000	8000	Combined [dB]
Sound Power, Lw [dB]	95.0	99.0	102.0	100.0	100.0	94.0	89.0	84.0	76.0	107.0

Resulting A-weighted sound power level, LwA

Freq. [Hz]	31	63	125	250	500	1000	2000	4000	8000	Combined [dBA]
A-Weight [dB]	-39.4	-26.2	-16.1	-8.6	-3.2	0.0	1.2	1.0	-1.1	-
Sound Power, LwA [dBA]	55.6	72.8	85.9	91.4	96.8	94.0	90.2	85.0	74.9	100.2

Figure B.1 Substation Transformer Sound Power Calculations

Amherst Island SWT-3.2-113 2A, Rev.0, Max. Power 2772 kW Standard Acoustic Emission, Hub Height 99.5 m

Sound Power Levels

The sound power level is presented with reference to the code IEC 61400-11 ed. 2.1 (2006-12) based on a hub height of 99.5 m and a roughness length of 0.05 m as described in the IEC code. The sound power levels (L_{WA}) presented are valid for the corresponding wind speeds referenced to a height of 10.0 m above ground level.

Wind speed [m/s]	3	4	5	6	7	8	9	10	11	12	Up to cut-out
Typical Values	90.9	95.5	100.1	103.8	104.0	104.0	104.0	104.0	104.0	104.0	104.0

Table 1: Noise emission, L_{WA} [dB(A) re 1 pW]

Typical Sound Power Frequency Distribution

Typical spectra for L_{WA} in dB(A) re 1pW for the corresponding center frequencies are tabulated below for 6 - 10 m/s referenced to a height of 10.0 m above ground level.

Octave band, center frequency [Hz]	typical Spectral Levels				
	Wind Speed (m/s)				
	6	7	8	9	10
63	89.8	91.0	91.3	91.2	91.5
125	91.3	93.0	93.6	93.2	93.7
250	94.9	94.8	94.3	95.0	95.2
500	96.5	96.3	95.5	95.6	96.2
1000	97.7	97.6	97.5	97.6	97.4
2000	97.2	97.3	97.1	97.2	96.9
4000	94.4	95.3	96.1	95.6	95.0
8000	82.7	83.5	83.2	83.0	84.6

Table 2: Typical octave band for 6 - 10 m/s, L_{WA} [dB(A) re 1 pW]

Tonality

Typical tonal audibility for the Siemens wind turbine generators has not exceeded 3 dB(A) as determined in accordance with IEC 61400-11 ed. 2.1 (2006-12)

Measurement Uncertainty

A measurement uncertainty range of -1.5dB(A) to +1.5dB(A) is applicable.

Amherst Island SWT-3.2-113 2A, Rev.0, Max. Power 2942 kW Standard Acoustic Emission, Hub Height 99.5 m

Sound Power Levels

The sound power level is presented with reference to the code IEC 61400-11 ed. 2.1 (2006-12) based on a hub height of 99.5 m and a roughness length of 0.05 m as described in the IEC code. The sound power levels (L_{WA}) presented are valid for the corresponding wind speeds referenced to a height of 10.0 m above ground level.

Wind speed [m/s]	3	4	5	6	7	8	9	10	11	12	Up to cut-out
Typical Values	90.9	95.5	100.1	104.7	105.0	105.0	105.0	105.0	105.0	105.0	105.0

Table 1: Noise emission, L_{WA} [dB(A) re 1 pW]

Typical Sound Power Frequency Distribution

Typical spectra for L_{WA} in dB(A) re 1pW for the corresponding center frequencies are tabulated below for 6 - 10 m/s referenced to a height of 10.0 m above ground level.

Octave band, center frequency [Hz]	typical Spectral Levels				
	Wind Speed (m/s)				
	6	7	8	9	10
63	90.0	90.8	91.4	91.4	91.2
125	92.8	92.9	93.4	93.9	93.7
250	95.9	96.0	95.8	96.2	96.1
500	97.5	97.6	97.1	96.7	97.3
1000	98.6	98.8	98.5	98.2	98.9
2000	98.1	98.4	99.0	99.1	98.5
4000	95.3	96.3	96.0	95.9	95.8
8000	83.4	84.1	84.1	83.8	82.0

Table 2: Typical octave band for 6 -10 m/s, L_{WA} [dB(A) re 1 pW]

Tonality

Typical tonal audibility for the Siemens wind turbine generators has not exceeded 3 dB(A) as determined in accordance with IEC 61400-11 ed. 2.1 (2006-12)

Measurement Uncertainty

A measurement uncertainty range of -1.5dB(A) to +1.5dB(A) is applicable.



SIEMENS



Siemens D3 platform – 3.0-MW and 3.2-MW direct drive wind turbines

Reduced complexity,
increased profitability

Answers for energy.



Your trusted partner

Siemens has been a major driver of innovation in the wind power industry since 1980 when wind turbine technology was still in its infancy.

Technology has changed with the times, but Siemens's commitment to providing its customers with proven wind turbine solutions remains the same.

The combination of robust and reliable turbines, highly efficient solutions for power transmission and distribution, and a deep understanding of the entire energy market ensures that Siemens will continue to take the wind power industry to new levels.

Long-lasting customer relationships – based on a track record of successful, reliable project deliveries – provide a sound, sustainable, and profitable investment.

Drawing on more than 30 years of experience in the wind power industry, a strong focus on renewables, and a global network of highly skilled and trained employees, Siemens has proven itself to be a trustworthy and reliable business partner and will continue to be so in the future.

With an increasing number of turbines being installed at inland, coastal, and offshore sites, reliability and best in class maintenance under challenging conditions are essential for optimizing the return on investment throughout a project's life cycle.

Over the past 30 years, Siemens has accumulated millions of hours of service experience. Drawing on this substantial knowledge, the company has established a flexible range of service solutions that are designed to optimize the output of wind turbines.



Intelligent ways to drive down the cost of electricity

Wind power is coming of age. It could soon be directly competitive with traditional energy sources. Driving down the levelized cost of wind energy is a key target for Siemens as we strive to make wind power independent of subsidies.

Innovation and industrialization are the main drivers of this. And our new platform strategy, founded on the knowledge and experience of more than 30 years in wind power, is a milestone along this path.

Standardization and modularization are fundamental to the new platform approach because they allow us to streamline the entire manufacturing and installation process. The organization of our product platforms into categories allows standardized modules, such as rotors, generators, towers, and hubs – to be used with different products. The total number of different components is thus kept to a minimum.

Each of our products is now a member of one of four platforms: the Siemens G2, Siemens D3, Siemens G4, and Siemens D6. “G” denotes geared turbines, “D” signifies direct drive technology, and the associated numbers represent the predominant power rating.

Therefore, the D3 platform is comprised of onshore direct drive wind turbines with a power rating of 3.0-MW and 3.2-MW.

Through continuous monitoring of our installed D3 fleet, Siemens engineers were able to boost the performance of the entire product platform. We increased the standard rating of 3.0-MW to 3.2-MW. This translates into 200,000 additional watts of product capacity for you, and 200,000 more reasons to choose Siemens.

Outstanding performance with reduced complexity

The Siemens 3.0-MW and 3.2-MW wind turbines of the D3 platform embody proven innovation in the field of direct drive generators, with hundreds of units already installed and operational.

As wind power plants develop capacities similar to conventional power plants, power-generation companies throughout the world are striving for greater efficiency and cost-effectiveness. Siemens’s solution: increase availability and profitability through innovative technology and reduced complexity.

Siemens direct drive turbines of the D3 and D6 platforms offer innovation through the consistent implementation of a common, highly efficient generator concept. With less than half the moving parts of a conventional geared turbine, the direct drive wind turbines improve performance, reliability, and maintainability. In addition, the compact design allows for cost-effective transportation and installation.



Performance and profitability go hand in hand

With its direct drive wind turbines, Siemens started with the ambitious goal of making a more cost-effective machine in order to become competitive with conventional power plants. Thanks to innovative engineering, that vision is becoming a reality.

In designing a wind turbine, a holistic view of the design, and construction, materials, processes, manufacture, and installation is critical. The gearless 3.0-MW and 3.2-MW wind turbines carefully balance all these factors in a compact system. Service personnel have been involved in the development process in order to optimize working conditions and serviceability.

Reduced complexity

The Siemens D3 platform offers the simplest and most straightforward wind turbine design. Regardless of the reliable track record of gearboxes over the years, the gearbox is fundamentally the most complex component

of a wind turbine. Eliminating the gearbox reduces complexity and can increase reliability.

Replacing the gearbox, the coupling, and the high-speed generator with a low-speed generator eliminates two-thirds of the conventional drivetrain arrangement. As a result, the number of rotating and wear-prone parts is vastly reduced compared to a geared machine.

Siemens has opted for a permanent magnet generator for improved efficiency. Unlike an electrically-excited machine with a gearbox, a permanent magnet-excited machine does not expend any energy on the excitation itself. The D3 platform wind turbine generators also have an outer rotor, where the rotor spins on the outside of the stator. This design feature allows the rotor to operate within narrower tolerances, which helps to keep the dimensions of the nacelle compact.

Simplified design

Due to the removal of the gearbox and other design simplifications, Siemens has given service technicians more space within the nacelle. Here, key components are readily accessible and can be replaced without impacting others. The wind turbines of the D3 platform have a dual-cooling system that provides even cooling of the generator via a top-mounted, passive cooling system for improved energy efficiency.

The key components of a wind turbine – the blade, rotor hub, tower, and controller – are all adopted from the existing Siemens geared-turbine portfolio. The utilization of proven components alongside rigorous testing on rigs and in the field enables Siemens to eliminate many of the variables traditionally associated with the introduction of such an innovative product.

Innovative tower solution

Higher towers significantly increase the energy yield of a wind turbine. At the same time, they pose considerable challenges in terms of transportability and cost. Siemens offers an innovative and economically viable tower concept to allow its wind turbines to reach heights above 100 meters. The bolted steel shell tower consists of multiple

tower sections, which are mounted on top of each other and assembled together on-site. The modular concept of the bolted steel shell tower allows for very high hub heights (in excess of 140 meters) with very few requirements in terms of transport. The tower is erected in a short time and requires minimal maintenance. In fact, the HRC bolts require no re-torquing during the tower's lifetime.

Ease of transportation and construction

The D3 platform has a compact, lightweight design and has been engineered to meet even the most demanding of transportation routes. Key bridge and tunnel clearance specifications have been carefully considered when engineering the machine, and as a result, the 3.0-MW and 3.2-MW wind turbines can navigate many of the most demanding transport routes.

Simplified design and an innovative tower concept allow for maximum profitability.



Proven technology, advanced performance

Grid performance with the Siemens NetConverter®

Siemens sets the standard in the field of grid compliance. Power conversion is implemented by the Siemens's NetConverter® system. This system is characterized by full conversion of the power generated, efficiently decoupling generator and turbine dynamics from the grid.

The NetConverter® system offers maximum flexibility in the turbine's response to voltage and frequency control, fault ride-through, and output adjustment. As a result, Siemens wind turbines can be configured to comply with a variety of relevant grid codes in major markets and can be readily connected to the grid.

Siemens IntegralBlade® technology

The rotors of the D3 platform benefit from blades manufactured using patented IntegralBlade® technology.

The blades are made in one piece from fiberglass-reinforced epoxy resin during a single production step. As a result, all glue joints – the potential weak points that could expose the structure to cracking, water ingress, ice formation, and lightning damage – are eliminated.

Siemens WebWPS SCADA system

Via a standard Web browser, the Siemens WebWPS SCADA system provides a variety of status views of electrical, mechanical, meteorological, and grid station data as well as operation and fault status.

Wind turbine condition monitoring

Siemens's wind turbine condition monitoring compares the vibration levels of the main nacelle components with a set of established reference spectra and instantly detects deviations from normal operating conditions.

This allows Siemens to proactively plan the service and maintenance of the wind turbines, as any unusual event can be categorized and prioritized based on severity.

Turbine Load Control (TLC)

The Turbine Load Control system continuously monitors the structural loading on the wind turbine. In case the loads exceed normal values, the turbine automatically regulates operation to bring loads back within the design envelope.

In addition, the TLC system – an optional feature of the D3 platform – monitors the accumulated fatigue loading on the turbine and thus provides key input for fact-based asset management.

High Wind Ride Through (HWRT)

Wind turbines are normally programmed to shut down if the 10-minute mean wind speed exceeds 25 m/s. This may lead to significant challenges for the grid system if the turbines in large wind farms are shut down more or less simultaneously.

The Siemens D3 platform works to enhance grid stability due to High Wind Ride Through – an optional feature of the D3 platform. This replaces the fixed high-wind shut-down threshold with an intelligent load-based reduction in output power at some storm-level wind speeds.

Service

From the highly qualified local technician to the senior engineer at service headquarters, it is the Siemens service team's track record and the vast amount of experience gained over time that makes the difference.

Siemens offers tailor-made service solutions for each of our turbine platforms, e.g. the SWPS-100B, the SWPS-200A, and the SWPS-300W service solutions for onshore wind turbines.

Further improvements in safety

Safety is at the heart of all Siemens operations. From production to installation, operation, and service, Siemens strives to set the standard for a zero-harm culture.

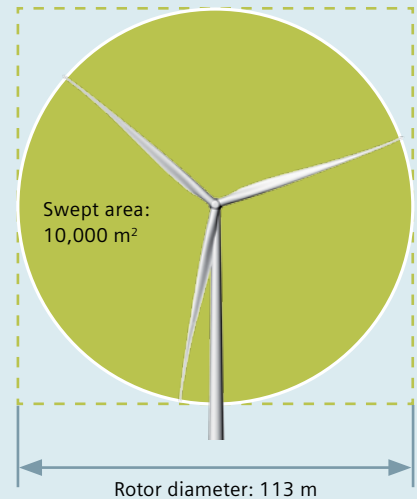
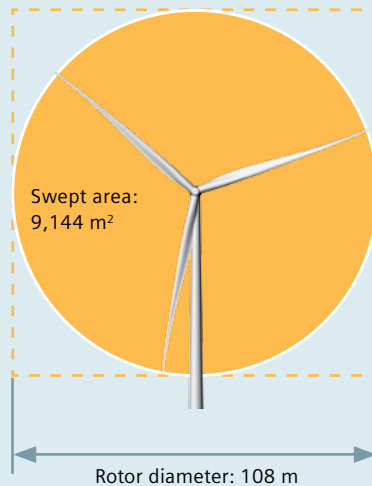
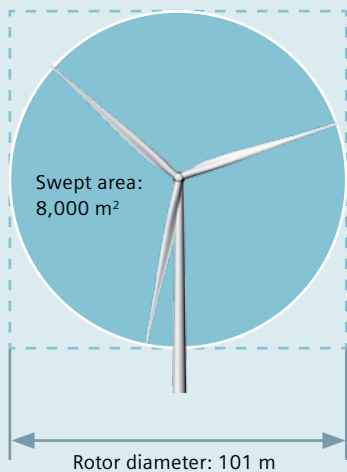

SWT-3.0-101 / SWT-3.2-101

IEC Class	IA
Rotor diameter	101 m
Blade length	49 m
Swept area	8,000 m ²
Hub height	74.5 – 99.5 m*
Power regulation	Pitch regulated
Annual output at 8.5 m/s	12,814 MWh (3.0-MW) 13,135 MWh (3.2-MW)
Nacelle weight	78 tons
Rotor weight	60 tons

SWT-3.0-108 / SWT-3.2-108

IEC Class	IA
Rotor diameter	108 m
Blade length	53 m
Swept area	9,144 m ²
Hub height	79.5 m
Power regulation	Pitch regulated
Annual output at 8.5 m/s	13,228 MWh (3.0-MW) 13,650 MWh (3.2-MW)
Nacelle weight	78 tons
Rotor weight	60 tons

SWT-3.0-113 / SWT-3.2-113

IEC Class	IIA
Rotor diameter	113 m
Blade length	55 m
Swept area	10,000 m ²
Hub height	79.5 – 142 m*
Power regulation	Pitch regulated
Annual output at 8.5 m/s	13,938 MWh (3.0-MW) 14,402 MWh (3.2-MW)
Nacelle weight	78 tons
Rotor weight	67 tons

*Site specific

The toughest turbine for the roughest conditions

Extreme wind conditions place tremendous loads on a turbine. This turbine is built to deliver reliable performance under the world's harshest operating conditions.

The turbine utilizes the same rotor as Siemens's SWT-2.3-101 geared machine. Through the application of proven components, Siemens balances innovation with a secure investment.

The durable choice for strong wind conditions

When winds are strong, the turbine offers a superior combination of a large rotor and robust design.

The B53 quantum blade of the 108-meter rotor uses Siemens's innovative aeroelastic blade design, which allows a larger rotor diameter and higher energy output without compromising structural loads. As a result, the turbine provides a lower cost of energy in heavy wind conditions.

Getting the most out of moderate conditions

Offering the largest rotor in the Siemens D3 platform, the turbine is designed to increase energy output at sites with moderate wind conditions.

Once again, the competitive edge of a Siemens turbine is based on innovative blade design. The B55 quantum blade benefits from an optimized root design that derives maximum power from the wind. Furthermore, the turbine has reduced noise emissions due to a lower rotor speed. With its combination of high energy output and low noise levels, this turbine is the ideal choice for most inland sites across the globe.

Offering three rotor sizes and a standard rating of 3.0-MW and 3.2-MW, the D3 platform is a perfect combination of performance and profitability for all wind conditions.

Published by and copyright © 2014:
Siemens AG
Energy Sector
Freyeslebenstrasse 1
91058 Erlangen, Germany

Siemens AG
Wind Power
Beim Strohause 17-31
20097 Hamburg, Germany
siemens.com/wind

For more information, please contact
our Customer Support Center.
Phone: +49 180 524 70 00
Fax: +49 180 524 24 71
(Charges depending on provider)
E-mail: support.energy@siemens.com

Wind Power
Order No. E50001-E310-A199-X-7600
RS 15_01_003

Printed on elementary chlorine-free bleached paper.

All rights reserved.

Trademarks mentioned in this document are the property
of Siemens AG, its affiliates, or their respective owners.

Subject to change without prior notice.

The information in this document contains general
descriptions of the technical options available, which may
not apply in all cases. The required technical options
should therefore be specified in the contract.

Technical Specifications SWT-3.2-113 IEC IIA

Rotor

Type	3-bladed, horizontal axis
Position.....	Upwind
Diameter.....	113 m
Swept area	10,000 m ²
Nominal speed.....	14.4 rpm
Speed range	4-16.5 rpm
Power regulation	Pitch regulation with variable speed
Rotor tilt	6 degrees

Blade

Type	Self-supporting
Blade length	55 m
Tip chord	0.63 m
Root chord	4.2 m
Aerodynamic profile	Siemens proprietary airfoils, FFA-W3-XXX
Material	GRE
Surface gloss	Semi-gloss, < 30 / ISO2813
Surface color	Light grey, RAL 7035

Aerodynamic Brake

Type	Full span pitching
Activation	Active, hydraulic

Load-Supporting Parts

Hub	Nodular cast iron
Fixed shaft	Nodular cast iron
Nacelle bed frame.....	Nodular cast iron

Mechanical Brake

Type	Hydraulic disc brake
Position	Generator rear end
Number of callipers	3

Canopy

Type	Totally enclosed
Surface gloss	Semi-gloss, 20-40 / ISO- 2813
Color	Light grey, RAL 7035
Material.....	Fire retardant GFRP with inlaid EMC shielding

Generator

Type	Synchronous, PMG
Nominal power	3.4 MW

Grid Terminals (LV)

Nominal power	3.2 MW
Voltage	690 V
Frequency	50 Hz or 60 Hz

Yaw System

Type	Active
Yaw bearing	Externally geared
Yaw drive	8 (optional 10) electric gear motors
Yaw brake	Passive friction brake

Controller

Type	Microprocessor
SCADA system	WPS
Controller designation	SICS

Tower

Type	Tubular steel tower
Hub height	83.5 m, 88 m, 92.5 m, 115 m, 127.5 m, or 142.5 m
Corrosion protection	Painted
Surface gloss	Semi-gloss, 20-40 / ISO- 2813
Color	Light grey, RAL 7035

Operational Data

Cut-in wind speed	3-5 m/s
Nominal power at	12-13 m/s
Cut-out wind speed	32 m/s with High Wind Ride Through
High Wind Ride Through activation	Above 22 m/s
Maximum 3 s gust	59.5 m/s

Weights (approximately)

Rotor	67 Metric tons
Nacelle	78 Metric tons

Siemens Wind Power and its affiliates reserve the right to change the above specifications without prior notice.

SIEMENS

December 16, 2014

To: Ontario Ministry of Environment

Re: Amherst Island Wind Project

Dear Sir/Madam,

With respect to the Amherst Island Wind Project, Siemens Canada Limited ("Siemens") will provide its SWT D3 Direct Drive wind turbine generators, with a maximum power output of 2,772 kW or 2,942 kW each. In accordance with the Turbine Supply Agreement between Siemens and Algonquin Power, Siemens will guarantee the maximum broadband sound power levels for those Units at the maximum rated power level shown in the table below.

	Maximum Rated Power Level	Maximum Broadband Sound Power Level	Hub Height
SWT D3 Direct Drive Wind Turbine Generator, Maximum Power rating 2,772kW	2,772 kW	104.0 dB	99.5m
SWT D3 Direct Drive Wind Turbine Generator, Maximum Power rating 2,942kW	2,942 kW	105.0 dB	99.5m

The warranted sound power level is presented with reference to the IEC 61400-11:2002 Code with amendment 1 dated 2006-05 based on a hub height of 99.5m.

Siemens has performed acoustic testing of its SWT-2.3-113 and SWT-3.2-113 model wind turbine generators in accordance with the IEC 61400-11:2002 Code with amendment 1 dated 2006-05 and confirms that the attached acoustic emission datasheet is consistent with that testing. Executive summaries for both test reports are attached hereto.

Based on the testing of the SWT-2.3-113 and SWT3.2-113 model wind turbine generators, Siemens does not expect that the tonality generated by the SWT D3 Direct Drive wind turbine generators listed above with a Maximum Power of 2,772 kW or a Maximum Power of 2,942 kW will be higher than 3 dB when tested in accordance with the IEC 61400-11:2002 Code with amendment 1 dated 2006-05.

Best regards,

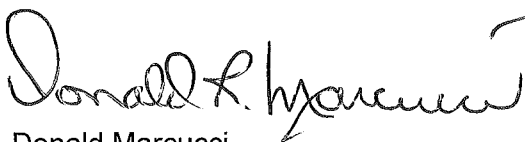

Donald Marcucci
Siemens Energy, Inc.
Wind Power Americas
Enclosures (3)

cc: Alex Tsopelas, Algonquin Power

TEST REPORT

This Test Report may only be reproduced in full.
The test results are valid for the tested object only.
Text written in *italics* is not part of the accredited test.



Wind Turbine noise measurement, IEC 61400 ed. 2.1
Siemens SWT-3.2-113 2A Rev. 0 mode -2 dB

Page 1 of 27 pages

Report no.: P6.119.15
Aarhus 31. March 2015
Project: 35.6342.27

Client:
Siemens Wind Power A/S
Borupvej 16
DK-7330 Brande
Denmark

Commissioned by:
Tomas R. Hansen

Telephone: +45 9942 2605

Prepared by:
Mathias Bødker Borup

Checked by:
Bo Søndergaard

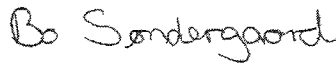
Signatory:

Bo Søndergaard

Ver. 2007.11.30 PHe

Summary:

For the Siemens wind turbine type SWT-3.2-113 2A mode -2dB, serial number 3000364, the following acoustic data has been determined according to IEC 61400-11 Edition 2.1:

Standardized wind speed	[m/s]	6	7*	8*	9*	10*
Power	[kW]	1781	2508	2746	2771	2772
Apparent Sound Power Level						
L _{WA}	[dB re 1 pW]	102,3	102,5	102,2	102,2	102,6
Uncertainty U _c	[dB]	0,9	1,0	1,1	1,3	1,2
Tonal Audibility ΔL _a	[dB]	-9,8	-11,8	-	-10,9	-7,7

* correspond to more than 95% of rated power.

Third octave band spectra are found in Figure 12.

The measurements were carried out on the 21st of March 2015, at Flø wind farm, Brande, Denmark.



Acoustica Acoustics · Noise · Vibrations

Dusager 12
DK 8200 Århus N
Denmark

Phone +45 8210 5100
Direct phone +45 8210 5149
Mobile phone +45 2723 5149

Web www.grontmij.dk
E-mail bo.sondergaard@grontmij.dk
File P6.119.15 SWT-3.2-113 2A mode -2 dB .docx

CVR-no. 48233511

TEST REPORT

This Test Report may only be reproduced in full.
The test results are valid for the tested object only.
Text written in *italics* is not part of the accredited test.



Wind Turbine noise measurement, IEC 61400 ed. 2.1
Siemens SWT-3.2-113 2A Rev. 0 mode -1 dB

Page 1 of 27 pages

Report no.: P6.120.15
Aarhus 31. March 2015
Project: 35.6342.27

Client:
Siemens Wind Power A/S
Borupvej 16
DK-7330 Brande
Denmark

Commissioned by:
Tomas R. Hansen
Telephone: +45 9942 2605

Prepared by:
Mathias Bødker Borup

Signatory:

Checked by:
Bo Søndergaard

Bo Søndergaard

Ver. 2007.11.30 PHe

Summary:

For the Siemens wind turbine type SWT-3.2-113 2A mode -1 dB, serial number 3000364, the following acoustic data has been determined according to IEC 61400-11 Edition 2.1:

Standardized wind speed	[m/s]	6	7	8*	9*	10*
Power	[kW]	1788	2564	2893	2940	2942
Apparent Sound Power Level L_{WA}	[dB re 1 pW]	103,6	104,1	103,6	103,6	104,1
Uncertainty U_c	[dB]	1,1	1,1	1,4	1,4	1,5
Tonal Audibility ΔL_a	[dB]	-	-8,5	-6,2	-7,9	-7,8

* correspond to more than 95% of rated power.

Third octave band spectra are found in Figure 12.

The measurements were carried out on the 21st of March 2015, at Flø wind farm, Brande, Denmark.



Acoustica Acoustics · Noise · Vibrations

Dusager 12
DK 8200 Aarhus N
Denmark

Phone +45 8210 5100
Direct phone +45 8210 5149
Mobile phone +45 2723 5149

Web www.grontmij.dk
E-mail bo.sondergaard@grontmij.dk
File P6.120.15 SWT-3.2-113 2A mode -1 dB .docx

CVR-no. 48233511

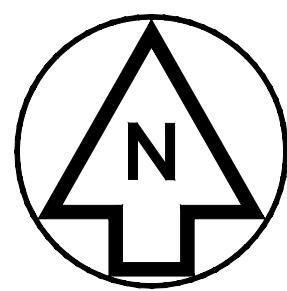

SUBSTATION TRANSFORMER
POINT SOURCE LOCATION
E 363269.13
N 4891095.48

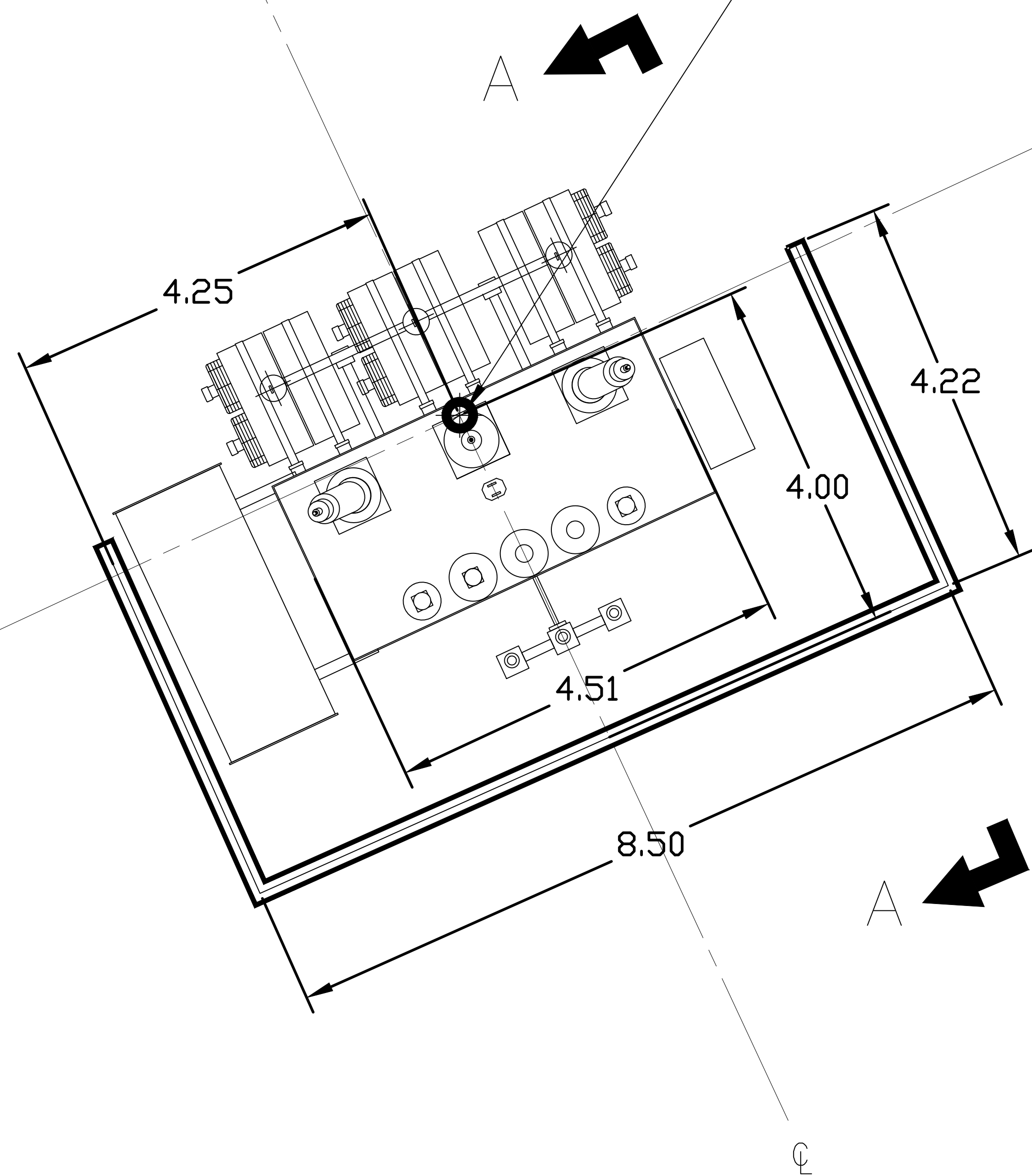

PLAN VIEW

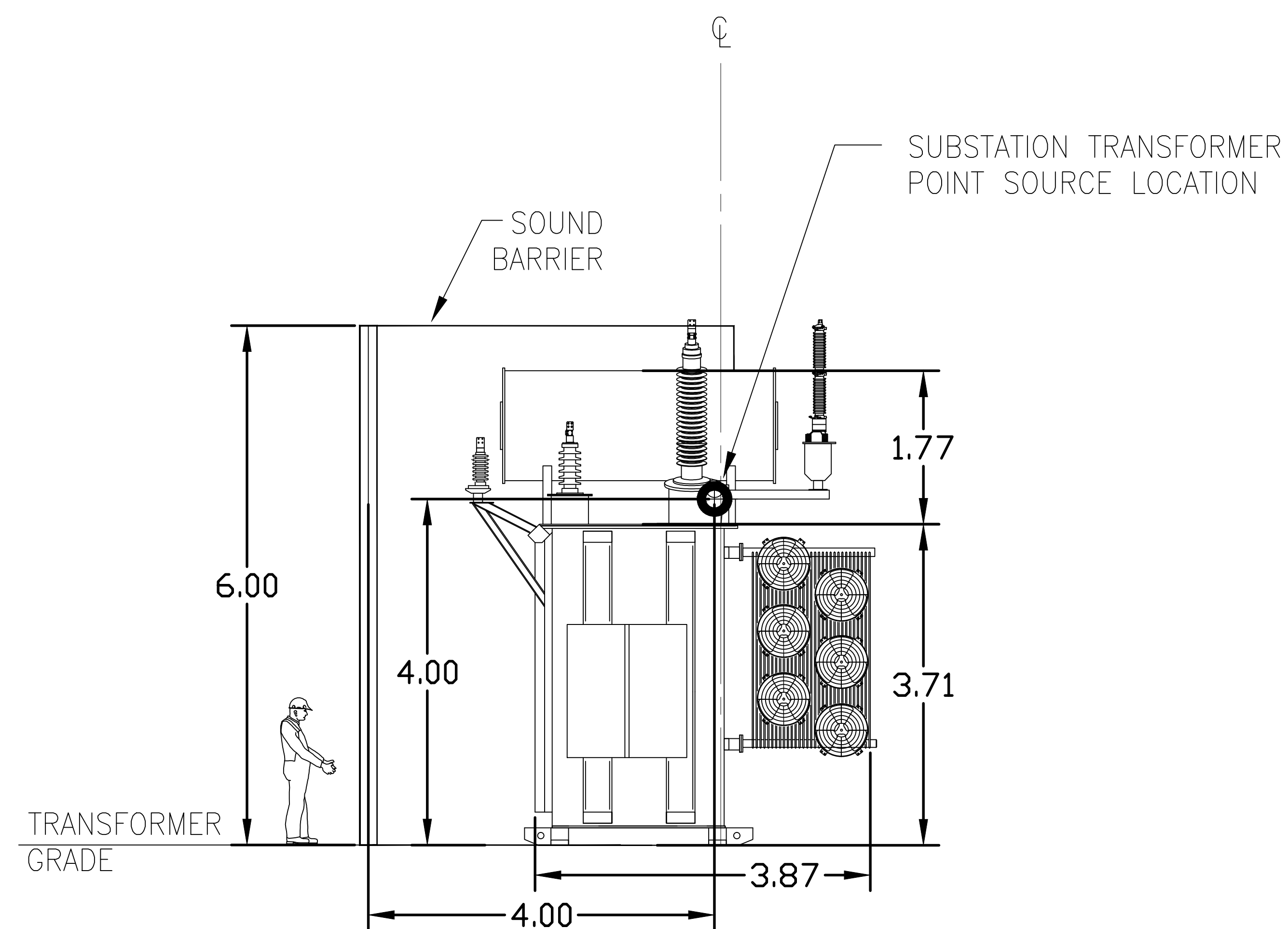

SECTION VIEW
A-A

ALL DIMENSIONS IN METERS

PROJECT NUMBER: 30160-06-80467-1
PAGE: 1 of 4
DATE: November 6, 2006

662 Cromwell Avenue Telephone : (651) 645-3601
 Saint Paul, MN 55114 Toll Free : (888) 645-TEST
 USA Telefax : (651) 659-7348
 Website : www.twincitytesting.com

Investigative Chemistry Geotechnical Construction Materials
 Non Destructive Testing Failure Analysis Product Evaluation
 Metallurgical Analysis Materials Testing Welder Qualification

**SOUND ABSORPTION TESTING CONDUCTED ON
 COMPOSITE CONCRETE PANELS**

(Richmond Panel- Lid Side - Natural Stone Pattern)

**Prepared for:
 DURISOL, INC.
 Attn. Jason Scarrow
 PO Box 400
 51 Arthur Street South
 Mitchell, Ontario, Canada NOK1N0**

Client Purchase Order Number: Verbal

Prepared By:



**Mathew N. Botz
 Project Manager
 Product Testing Department
 (651) 659-7353**

Reviewed By:



**Kyle T. Hall
 Sr. Engineering Technician
 Product Testing Department**

The test results contained in this report pertain only to the samples submitted for testing and not necessarily to all similar products.

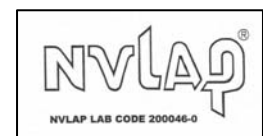

Noise Reduction Coefficient (ASTM C423-02)

INTRODUCTION:

This report presents the results of sound absorption testing conducted on concrete panels. The test unit was submitted by Mr. Jason Scarrow. This work was completed on October 20, 2006.

This report must not be reproduced except in full with the approval of Stork Twin City Testing Corporation. The data in this report relates only to the items tested.

Stork Twin City Testing Corporation has been accredited by the U.S. Department of Commerce and the National Institute of Standards and Technology (NIST, formerly NBS) under their National Voluntary Laboratory Accreditation Program (NVLAP) for conducting ASTM C423 test procedures. This report may not be used to claim product endorsement by NVLAP, NIST or any agency of the U.S. Government.

TEST RESULTS SUMMARY:

Durisol Concrete Panels

				Test Results		
Test #	Panel Identification	Exposed Surface	Weight (psf)	NRC	SAA	--
1	Richmond Panel, Natural Stone Pattern	Lid Side	37.8	0.80	0.80	--

See 'TEST DATA' section for detailed results.

SPECIMEN DESCRIPTION: (Also see "Test Results")

The specimens were described as concrete panels and were identified by Durisol Inc. as Richmond Panels, RDNBP, with a Natural Stone / Natural Stone pattern. Each panel measured 48" x 36-1/2" x 8" and weighed 460-lbs each (37.8-psf). A total of six (6) panels were tested, for a total of 72-ft². The 'Lid' surface with the Natural Stone Pattern was tested. The panels were positioned in a 2x3 orientation. Side by side joints were flat butt-joints and stacked panels had tongue & groove joints.

Information and statements in this report are derived from material, information and/or specifications furnished by the client and exclude any expressed or implied warranties as to the fitness of the material tested or analyzed for any particular purpose or use. This report is the confidential property of our client and may not be used for advertising purposes. This report shall not be reproduced except in full, without written approval of this laboratory. The recording of false, fictitious or fraudulent statements or entries on this document may be punished as a felony under Federal Statutes including Federal Law Title 18, Chapter 47

PROJECT NUMBER: 30160-06-80467-1

PAGE: 3 of 4

DATE: November 6, 2006

TEST PROCEDURE**Sound Absorption Test**

ASTM C 423-02, "Sound Absorption and Sound Absorption Coefficient by the Reverberation Room Method", was followed in every respect. The panels were tested in Type A Mounting (on the floor). The panel edge/perimeter was covered with 8" tall border walls constructed from 5/8" sheetrock

NRC was calculated by rounding the sound absorption coefficients for 250, 500, 1000 and 2000 Hz to the nearest 0.05. SAA was calculated by rounding the sound absorption coefficients for the twelve frequencies from 200 Hz to 2500 Hz to the nearest 0.01.

TEST EQUIPMENT:

<u>Manufacturer</u>	<u>Model</u>	<u>Description</u>	<u>S/N</u>
Norwegian Electronics	NE830	Real Time Analyzer	11511
Brüel & Kjær	3923	Rotating Microphone Boom	815424
Norsonic (Source Rm)	1230	Pressure Condenser Microphone	26361
Brüel & Kjær (Term Rm)	4192	Pressure Condenser Microphone	2360314

REMARKS:

The test sample will be retained for a period of **15-days** and then discarded unless notified by the client.

F:\Product\MMFILES\MNB\2006 - REPORTS

MNB\80467-Durisol-1.doc

PROJECT NUMBER: 30160-06-80467-1

PAGE: 4 of 4

DATE: November 6, 2006

TEST RESULTS:

Filename

test 1

ASTM C423 - Sound Absorption

Client

Durisol Inc.

Product

Richmond Panel

Model #

RDNBP

Quantity

1

Comment

Lid Side

Sample Size - Wt.

108.0 in x 96.0 in x 8" - 2760 lbs

Sample Description

Durisol Inc.: : Concrete Panel: Richmond Panel - RDNBP : Natural Stone / Natural Stone Pattern : 3' x 4' at 460-lbs each, 6 panels total :

Time Stamp

Fri, Oct 20, 2006 - 10:30 AM

Total Sample Area

72.0 ft²

F (Hz)	Absorption Coefficient	Absorption (Sabins)*
100	0.16	11.53
125	0.29	21.14
160	0.26	18.73
200	0.43	30.66
250	0.53	38.49
315	0.61	43.93
400	0.78	55.85
500	0.97	69.98
630	1.11	79.60
800	1.06	76.37
1000	0.87	62.99
1250	0.73	52.27
1600	0.72	52.07
2000	0.89	64.41
2500	0.91	65.16
3150	0.89	64.29
4000	0.90	64.62
5000	0.90	65.09

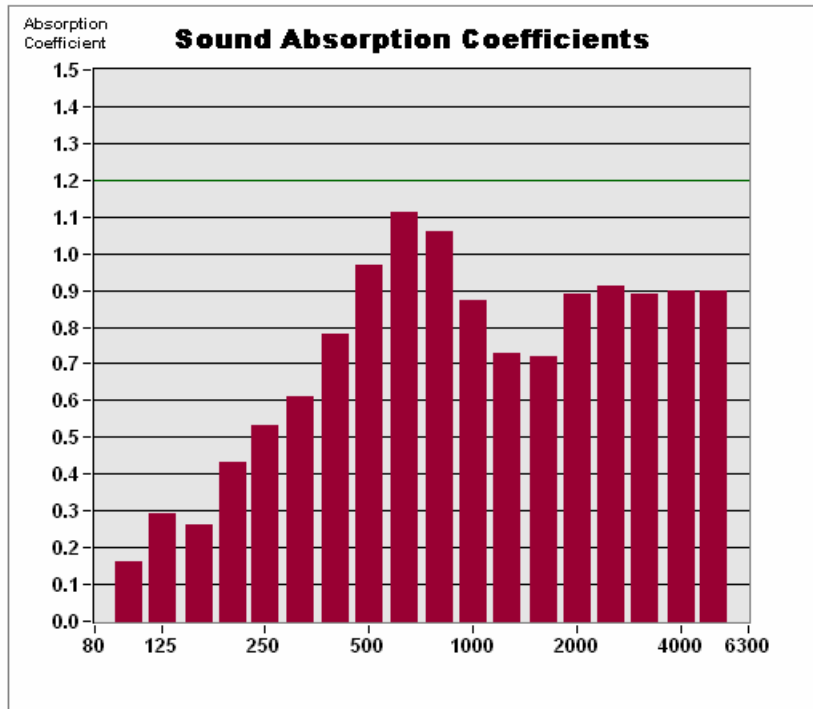

Temp (°C) R.H. (%) ATM (mbar)

21.5

54

982

* total absorption based on 72.0 ft²

SAA = 0.80 NRC = 0.80

Information and statements in this report are derived from material, information and/or specifications furnished by the client and exclude any expressed or implied warranties as to the fitness of the material tested or analyzed for any particular purpose or use. This report is the confidential property of our client and may not be used for advertising purposes. This report shall not be reproduced except in full, without written approval of this laboratory. The recording of false, fictitious or fraudulent statements or entries on this document may be punished as a felony under Federal Statutes including Federal Law Title 18, Chapter 47.

NOISE CONTROL /

DURISOL PRECAST NOISE BARRIERS



ATTRACTIVE, SOUND-ABSORPTIVE WALLS MADE OF DURABLE, FIELD-PROVEN
DURISOL MATERIAL

Armtec's Durisol precast noise barriers are made of a proprietary material consisting of organic softwood shavings processed to an acoustically engineered size and bonded together under pressure with Portland cement. Durisol is highly sound absorptive, porous, rigid, non-combustible, thermally insulating and freeze-thaw resistant.

Durisol precast noise barriers are panel and post systems. They are engineered in-house and specify the size for posts and the depth and diameter of footings. Standard steel posts or optional concrete posts can be accommodated.

Our standard systems are noise absorptive on both sides. They can also incorporate solid noise reflective or transparent elements, as well as integrated traffic barriers and retaining wall panels.

Visual appeal

Wide variety of architectural textures, patterns and colours

Acoustical Characteristics

Noise Reduction Coefficient of 0.70 or greater

Panel and post design

Lightweight, easy-to-install systems

TYPICAL APPLICATIONS

- Roads and highways
- Bridges
- Acoustic enclosures
- Residential developments

MITCHELL SYSTEM



Posts are spaced 3.65m apart

Wall height

Engineered for heights up to 6m

Versatile

Ideal for slope conditions, directional changes and areas with difficult site access

Flexible

Panels can be modified on-site for short bays

RICHMOND SYSTEM



Posts are spaced 4.56m apart

Wall height

Engineered for heights up to 11m or more

Economical

Fewer panels reduces on-site handling and installation costs

OHIO SYSTEM



Posts are spaced up to 7.3m apart

Wall height

Engineered for heights up to 11m or more

Cost-effective

Longest post spacing of the Durisol systems

Unique

Ideal for straight runs of wall with good site access where noise absorption is not required on the residential side

DURISOL NOISE BARRIER/RETAINING WALL



Combination noise barrier/retaining wall system

Innovative design

Noise barrier and retaining wall panels are stacked on top of each other

Minimal space requirements

Useful in tight spaces

Functional

Well-suited for areas where there are grade differences between the two sides of a barrier

Appendix C

Sound Pressure Levels at Points of Reception, Sound Pressure Contours from CADNA-A

Table C.1 Noise Impact Summary – Non-Participating Project Noise Receptors (325 receptors)

The table is sorted by noise receptors ID; “Vacant” = vacant lot noise receptor, “Existing” = existing dwelling; “Total” = combined contribution from all sources (substation and WTGs); blank cells in “Sound pressure” columns = POR at more than 5000 m from source.

Noise Receptor ID	Description	UTM NAD 83, Zone 18		Nearest Source Distance [m]			Sound Pressure [dBA]						
				WTG		Sub-station	POR at 4.5 m			POR at 1.5 within 30 m			Limit
		X	Y	Distance	ID	Distance	Substation	WTGs	Total	Substation	WTGs	Total	
R005	Existing	359893	4890564	710	S04	3418	12.9	38.3	38.3	12.0	37.2	37.2	40.0
R008	Vacant	363457	4888709	780	S20	2394	16.7	39.1	39.1	15.9	37.8	37.8	40.0
R011	Existing	366872	4893632	711	S30	4406	9.1	36.5	36.5	8.3	35.4	35.4	40.0
R014	Existing	366786	4893503	617	S30	4262	13.9	37.5	37.5	11.0	36.5	36.5	40.0
R017	Vacant	358641	4888158	1491	S01	5482		30.6	30.6		29.2	29.2	40.0
R020	Existing	362062	4886820	571	S11	4442	9.0	38.4	38.4	8.2	37.4	37.4	40.0
R021	Existing	360101	4890790	777	S04	3183	13.9	36.9	36.9	13.0	35.7	35.7	40.0
R022	Existing	362789	4891859	942	S31	902	34.2	34.0	37.1	29.2	32.8	34.4	40.0
R025	Existing	367198	4890237	722	S02	4022	9.9	38.0	38.0	6.2	36.8	36.8	40.0
R026	Existing	367812	4891038	803	S13	4544	8.6	38.0	38.0	2.9	36.7	36.8	40.0
R027	Existing	365542	4892944	1498	S30	2929	19.5	32.7	32.9	16.6	31.4	31.5	40.0
R029	Existing	367962	4891160	697	S13	4693	4.7	38.3	38.3	2.5	37.1	37.1	40.0
R031	Existing	359345	4888662	905	S01	4617	8.4	34.7	34.7	7.6	33.5	33.5	40.0
R033	Existing	360714	4891207	917	S22	2557	16.9	35.6	35.6	16.0	34.0	34.1	40.0
R035	Existing	361623	4891803	1058	S31	1792	25.9	34.3	34.9	23.4	33.0	33.4	40.0
R036	Existing	368045	4894070	1408	S28	5626		33.7	33.7		32.2	32.2	40.0
R040	Existing	365623	4888851	766	S21	3253	9.7	38.7	38.7	5.8	37.4	37.4	40.0
R041	Existing	359946	4890749	816	S04	3341	13.2	36.8	36.8	12.3	35.6	35.6	40.0
R045	Vacant	357945	4889761	1245	S01	5489		31.1	31.1		29.8	29.8	40.0
R052	Vacant	360318	4890871	800	S04	2959	14.9	36.7	36.8	14.0	35.5	35.5	40.0
R054	Vacant	365772	4893093	1277	S30	3202	18.2	33.3	33.4	15.3	32.0	32.1	40.0
R055	Vacant	359694	4890626	729	S29	3606	12.1	37.3	37.3	11.2	36.1	36.2	40.0
R056	Existing	364908	4890729	1057	S37	1679	20.9	36.9	37.0	19.9	35.5	35.6	40.0
R060	Existing	358523	4889966	770	S01	4878	7.6	35.5	35.5	6.8	34.4	34.4	40.0

Noise Receptor ID	Description	UTM NAD 83, Zone 18		Nearest Source Distance [m]			Sound Pressure [dBA]						Limit
				WTG		Sub- station	POR at 4.5 m			POR at 1.5 within 30 m			
		X	Y	Distance	ID	Distance	Substation	WTGs	Total	Substation	WTGs	Total	
R065	Existing	365563	4893048	1481	S30	3012	19.1	32.5	32.7	16.2	31.2	31.3	40.0
R066	Vacant	357961	4889769	1231	S01	5472		31.2	31.2		29.9	29.9	40.0
R068	Existing	364914	4890629	972	S37	1710	20.9	37.4	37.5	19.8	36.1	36.2	40.0
R069	Existing	367873	4894024	1366	S30	5456		33.8	33.8		32.4	32.4	40.0
R070	Existing	357913	4889708	1269	S01	5533		30.9	30.9		29.7	29.7	40.0
R074	Existing	369960	4893872	1145	S28	7244		33.7	33.7		32.4	32.4	40.0
R077	Vacant	367001	4889892	702	S02	3921	9.6	37.8	37.8	7.3	36.6	36.6	40.0
R078	Existing	360762	4891155	848	S22	2508	17.2	36.2	36.3	16.3	34.6	34.7	40.0
R079	Existing	359604	4890575	668	S29	3702	11.8	37.6	37.6	10.8	36.5	36.5	40.0
R080	Existing	362200	4887075	575	S11	4160	10.0	38.4	38.4	9.1	37.4	37.4	40.0
R081	Vacant	360150	4890764	735	S04	3137	14.1	37.2	37.3	13.2	36.1	36.1	40.0
R084	Vacant	361772	4892151	1260	S31	1832	25.6	32.3	33.1	23.1	30.9	31.6	40.0
R085	Existing	360668	4891181	939	S22	2602	16.7	35.6	35.6	15.8	34.0	34.1	40.0
R088	Vacant	360378	4885827	1399	S09	6010		30.8	30.8		29.6	29.6	40.0
R090	Existing	358709	4890096	715	S01	4668	8.2	36.6	36.6	7.5	35.5	35.6	40.0
R091	Existing	366966	4889848	709	S02	3902	9.8	37.7	37.7	7.5	36.5	36.5	40.0
R092	Existing	368778	4894417	1327	S28	6432		32.4	32.4		31.0	31.0	40.0
R093	Existing	359060	4888604	954	S01	4891	7.5	33.9	33.9	6.7	32.6	32.7	40.0
R094	Existing	367581	4893976	1168	S30	5185		34.1	34.1		32.7	32.7	40.0
R096	Existing	362996	4891908	1095	S31	857	34.7	33.2	37.0	32.7	31.9	35.3	40.0
R097	Existing	368666	4894336	1281	S28	6295		32.9	32.9		31.5	31.5	40.0
R098	Existing	359161	4890353	598	S29	4175	10.0	38.2	38.2	9.1	37.2	37.2	40.0
R099	Existing	368290	4891445	620	S13	5033		38.8	38.8		37.6	37.6	40.0
R100	Existing	357760	4889636	1414	S01	5699		29.9	29.9		28.6	28.6	40.0
R101	Existing	361821	4891454	673	S31	1491	28.1	37.5	38.0	25.6	36.4	36.7	40.0
R105	Existing	367259	4890334	771	S02	4062	8.9	37.9	37.9	5.9	36.7	36.7	40.0
R107	Existing	363640	4888526	957	S36	2596	15.8	37.9	37.9	15.0	36.4	36.5	40.0
R109	Existing	362949	4888140	792	S05	2972	14.5	37.7	37.7	13.6	36.4	36.4	40.0

Noise Receptor ID	Description	UTM NAD 83, Zone 18		Nearest Source Distance [m]			Sound Pressure [dBA]						Limit
				WTG		Sub- station n	POR at 4.5 m			POR at 1.5 within 30 m			
		X	Y	Distance	ID	Distance	Substation	WTGs	Total	Substation	WTGs	Total	
R112	Vacant	365595	4893202	1468	S30	3138	14.1	32.3	32.4	13.1	30.7	30.8	40.0
R114	Existing	366256	4889386	833	S27	3441	9.1	38.5	38.5	6.2	37.3	37.3	40.0
R118	Existing	367227	4893765	845	S30	4774	12.1	35.7	35.7	9.2	34.4	34.4	40.0
R122	Existing	363067	4891931	1157	S31	860	34.7	32.9	36.9	32.3	31.6	35.0	40.0
R123	Vacant	358576	4890039	770	S01	4810	7.8	35.7	35.7	7.0	34.6	34.6	40.0
R125	Existing	369190	4893990	869	S28	6591		35.7	35.7		34.4	34.4	40.0
R126	Existing	360677	4891064	871	S22	2592	16.7	36.4	36.4	15.7	35.0	35.0	40.0
R127	Existing	363902	4889092	977	S36	2101	17.9	38.7	38.8	17.0	37.2	37.3	40.0
R128	Existing	366068	4889271	813	S37	3341	7.7	38.7	38.7	6.6	37.5	37.5	40.0
R130	Existing	366563	4889572	804	S02	3629	10.1	38.2	38.2	9.2	37.0	37.0	40.0
R131	Existing	366560	4893285	590	S30	3953	10.8	37.9	37.9	9.8	37.0	37.0	40.0
R138	Existing	359899	4890759	851	S04	3387	13.0	36.6	36.6	12.2	35.4	35.4	40.0
R142	Existing	364168	4889387	794	S21	1930	18.7	39.0	39.0	10.3	37.6	37.6	40.0
R143	Vacant	367172	4893575	648	S30	4624	12.6	37.5	37.5	9.7	36.4	36.5	40.0
R145	Existing	364482	4890164	867	S19	1529	21.2	37.9	38.0	20.0	36.6	36.7	40.0
R149	Vacant	361532	4886274	938	S11	5125		35.6	35.6		34.3	34.3	40.0
R150	Vacant	366698	4889682	722	S02	3709	10.0	38.2	38.3	9.1	37.1	37.1	40.0
R151	Vacant	368981	4893971	851	S28	6395		35.9	35.9		34.7	34.7	40.0
R153	Vacant	368674	4893985	954	S28	6128		35.3	35.3		34.0	34.0	40.0
R157	Existing	360805	4891182	830	S22	2465	17.4	36.2	36.3	16.5	34.7	34.8	40.0
R159	Existing	358305	4889843	915	S01	5120		33.8	33.8		32.6	32.6	40.0
R160	Existing	366960	4889781	756	S02	3918	9.8	37.4	37.4	5.1	36.1	36.1	40.0
R162	Existing	357982	4889754	1207	S01	5455		31.4	31.4		30.1	30.1	40.0
R164	Existing	361050	4891333	785	S22	2232	18.7	36.3	36.3	17.8	35.1	35.2	40.0
R165	Existing	359814	4890699	829	S29	3478	12.7	36.9	36.9	11.7	35.7	35.7	40.0
R166	Existing	363313	4890643	742	S34	455	30.7	37.4	38.2	29.4	36.1	37.0	40.0
R167	Existing	359113	4888625	928	S01	4835	7.6	34.2	34.2	6.9	32.9	32.9	40.0
R168	Existing	361769	4886562	656	S11	4775	7.9	37.7	37.7	7.1	36.7	36.7	40.0

Noise Receptor ID	Description	UTM NAD 83, Zone 18		Nearest Source Distance [m]			Sound Pressure [dBA]						Limit
				WTG		Sub- station	POR at 4.5 m			POR at 1.5 within 30 m			
		X	Y	Distance	ID	Distance	Substation	WTGs	Total	Substation	WTGs	Total	
R173	Existing	364889	4890554	930	S37	1708	21.0	37.7	37.8	19.9	36.4	36.5	40.0
R175	Vacant	367980	4894001	1413	S28	5534		34.0	34.0		32.6	32.6	40.0
R176	Vacant	369874	4893890	1093	S28	7171		34.1	34.1		32.8	32.8	40.0
R180	Vacant	366000	4889211	814	S37	3318	7.3	38.7	38.7	6.1	37.5	37.5	40.0
R182	Existing	360558	4890989	925	S04	2713	16.1	36.4	36.5	15.2	35.1	35.2	40.0
R183	Vacant	359023	4888530	1032	S01	4962	7.2	33.3	33.3	1.2	32.0	32.0	40.0
R184	Vacant	370001	4892471	744	S33	6871		37.3	37.3		36.1	36.1	40.0
R185	Vacant	358849	4890145	676	S01	4521	8.7	37.5	37.5	8.0	36.5	36.5	40.0
R186	Vacant	358699	4890036	678	S01	4691	8.2	36.9	36.9	7.4	35.9	35.9	40.0
R190	Existing	365881	4893230	1194	S30	3373	17.5	33.4	33.5	12.3	31.9	32.0	40.0
R192	Existing	366628	4889597	788	S02	3678	10.0	38.0	38.0	9.1	36.8	36.8	40.0
R193	Existing	360787	4891238	880	S22	2487	17.3	35.7	35.8	16.4	34.3	34.3	40.0
R194	Existing	366226	4893109	831	S30	3577	12.3	35.8	35.9	11.3	34.6	34.6	40.0
R197	Existing	368995	4891793	734	S12	5768		38.1	38.1		36.9	36.9	40.0
R201	Existing	357805	4889647	1371	S01	5653		30.2	30.2		28.9	28.9	40.0
R202	Existing	367665	4894018	1246	S30	5278		33.8	33.8		32.4	32.4	40.0
R203	Existing	360989	4886500	604	S09	5130		38.2	38.2		37.2	37.2	40.0
R204	Existing	360702	4885983	1148	S09	5721		32.7	32.7		31.4	31.4	40.0
R205	Vacant	358654	4890060	727	S01	4730	8.0	36.3	36.3	7.3	35.2	35.2	40.0
R213	Vacant	362172	4886997	570	S11	4243	9.7	38.4	38.4	8.8	37.5	37.5	40.0
R215	Vacant	363116	4888322	717	S05	2778	15.2	38.5	38.5	14.4	37.3	37.3	40.0
R216	Vacant	360447	4885766	1429	S09	6030		30.7	30.7		29.4	29.4	40.0
R219	Vacant	359279	4888645	912	S01	4682	8.1	34.6	34.6	7.4	33.3	33.3	40.0
R222	Existing	359277	4890416	581	S29	4050	10.4	38.3	38.3	9.6	37.3	37.3	40.0
R226	Vacant	365709	4893089	1339	S30	3151	18.4	33.0	33.2	15.5	31.7	31.8	40.0
R227	Existing	365574	4888708	768	S21	3318	9.6	38.2	38.2	5.9	37.0	37.0	40.0
R231	Existing	362126	4891540	556	S31	1227	30.3	38.0	38.7	25.1	37.1	37.4	40.0
R233	Existing	358904	4888447	1136	S01	5106		32.5	32.5		31.2	31.2	40.0

Noise Receptor ID	Description	UTM NAD 83, Zone 18		Nearest Source Distance [m]			Sound Pressure [dBA]						Limit
				WTG		Sub- station	POR at 4.5 m			POR at 1.5 within 30 m			
		X	Y	Distance	ID	Distance	Substation	WTGs	Total	Substation	WTGs	Total	
R235	Vacant	365888	4889147	806	S37	3265	7.1	38.9	38.9	5.8	37.6	37.6	40.0
R239	Existing	366019	4889228	813	S37	3324	7.4	38.7	38.7	6.2	37.5	37.5	40.0
R244	Existing	360730	4891215	910	S22	2542	17.0	35.6	35.6	16.1	34.1	34.1	40.0
R245	Existing	365893	4893153	1166	S30	3334	13.3	33.7	33.7	12.3	32.2	32.3	40.0
R246	Existing	366902	4889729	765	S02	3881	9.8	37.4	37.4	5.1	36.2	36.2	40.0
R247	Existing	360436	4890915	839	S04	2839	15.5	36.6	36.7	14.6	35.4	35.4	40.0
R249	Vacant	362069	4885844	1428	S11	5387		31.5	31.5		30.2	30.2	40.0
R251	Vacant	366186	4889351	839	S27	3399	8.8	38.7	38.7	6.5	37.4	37.4	40.0
R253	Vacant	366368	4889475	809	S27	3497	10.1	38.5	38.5	5.9	37.3	37.3	40.0
R256	Vacant	368821	4891649	886	S12	5580		37.4	37.4		36.1	36.1	40.0
R259	Vacant	360151	4890808	775	S04	3132	14.2	36.9	36.9	13.2	35.6	35.7	40.0
R261	Existing	364674	4890296	851	S19	1617	21.0	38.1	38.2	19.9	36.8	36.9	40.0
R265	Existing	368058	4891269	622	S13	4792	4.7	38.8	38.8	2.7	37.7	37.7	40.0
R266	Existing	368149	4894137	1381	S28	5750		33.4	33.4		32.0	32.0	40.0
R267	Existing	365616	4893060	1428	S30	3060	18.9	32.7	32.9	15.9	31.4	31.5	40.0
R268	Existing	358467	4889930	801	S01	4942	7.4	35.1	35.1	6.6	34.0	34.0	40.0
R271	Existing	360734	4891167	877	S22	2536	17.0	36.0	36.0	16.1	34.4	34.5	40.0
R275	Existing	361386	4891597	943	S22	1949	24.9	35.2	35.6	19.5	33.9	34.1	40.0
R276	Existing	365906	4893126	1149	S30	3328	13.3	33.8	33.9	12.5	32.3	32.3	40.0
R278	Existing	366657	4889616	775	S02	3697	10.0	38.0	38.0	9.1	36.8	36.8	40.0
R280	Existing	364392	4890113	902	S19	1492	21.2	37.8	37.9	20.1	36.5	36.6	40.0
R282	Vacant	360437	4885826	1377	S09	5982		31.0	31.0		29.7	29.7	40.0
R283	Existing	362698	4891900	942	S31	987	28.8	33.9	35.1	28.2	32.2	33.7	40.0
R284	Vacant	361792	4892073	1181	S31	1771	26.0	32.8	33.6	23.6	31.5	32.1	40.0
R287	Vacant	366449	4893198	644	S30	3812	11.3	37.4	37.4	10.4	36.3	36.4	40.0
R288	Vacant	360601	4890918	864	S04	2674	16.3	37.0	37.1	15.4	35.8	35.8	40.0
R289	Vacant	366325	4893068	726	S30	3637	12.0	36.8	36.8	11.0	35.7	35.7	40.0
R291	Existing	363359	4888447	816	S05	2650	15.7	38.2	38.3	14.8	36.9	37.0	40.0

Noise Receptor ID	Description	UTM NAD 83, Zone 18		Nearest Source Distance [m]			Sound Pressure [dBA]						Limit
				WTG		Sub- station n	POR at 4.5 m			POR at 1.5 within 30 m			
		X	Y	Distance	ID	Distance	Substation	WTGs	Total	Substation	WTGs	Total	
R292	Existing	359462	4890503	602	S29	3853	11.2	38.1	38.1	10.2	37.1	37.1	40.0
R293	Existing	366725	4893495	637	S30	4207	9.8	37.3	37.3	9.0	36.3	36.3	40.0
R294	Vacant	360012	4890761	791	S04	3274	13.5	36.9	36.9	12.6	35.7	35.7	40.0
R295	Vacant	367768	4890950	892	S13	4501	8.8	37.7	37.7	3.9	36.4	36.4	40.0
R300	Existing	359452	4888735	863	S01	4488	8.8	35.3	35.3	8.0	34.0	34.0	40.0
R301	Existing	360046	4890779	790	S04	3239	13.7	36.8	36.9	12.8	35.6	35.6	40.0
R305	Existing	366313	4889429	820	S27	3470	10.1	38.5	38.5	6.2	37.3	37.3	40.0
R306	Existing	369559	4893778	802	S28	6838		36.6	36.6		35.4	35.4	40.0
R307	Existing	360208	4890842	792	S04	3071	14.4	36.7	36.7	13.5	35.5	35.5	40.0
R308	Existing	360481	4889210	870	S04	3366	12.8	36.9	37.0	11.9	35.6	35.6	40.0
R309	Existing	360738	4891222	908	S22	2534	17.0	35.5	35.6	16.2	34.1	34.2	40.0
R314	Existing	358234	4889849	984	S01	5187		33.2	33.2		32.0	32.0	40.0
R315	Existing	369384	4893953	876	S28	6749		35.6	35.6		34.4	34.4	40.0
R316	Existing	358861	4890030	571	S01	4535	8.7	38.6	38.6	7.9	37.7	37.7	40.0
R322	Existing	365833	4889090	834	S37	3256	7.2	38.8	38.8	5.9	37.5	37.5	40.0
R323	Vacant	366808	4889767	684	S02	3780	10.0	38.2	38.2	9.2	37.1	37.1	40.0
R324	Vacant	362433	4891633	611	S31	994	32.8	37.1	38.5	30.7	36.1	37.2	40.0
R326	Vacant	360840	4891142	778	S22	2430	17.6	36.7	36.7	16.7	35.4	35.5	40.0
R327	Vacant	367547	4890730	868	S14	4293	5.5	37.7	37.7	4.7	36.4	36.5	40.0
R331	Vacant	365802	4893036	1241	S30	3191	18.3	33.6	33.7	12.9	32.3	32.3	40.0
R332	Vacant	360897	4891167	751	S22	2373	17.9	36.8	36.9	17.0	35.6	35.7	40.0
R333	Existing	362146	4891676	677	S31	1264	25.5	36.2	36.6	24.6	35.0	35.4	40.0
R335	Existing	367376	4893735	863	S30	4882	11.7	35.8	35.8	8.9	34.6	34.6	40.0
R338	Existing	361116	4886227	892	S09	5323		35.4	35.4		34.2	34.2	40.0
R339	Existing	366644	4893340	561	S30	4053	10.4	38.3	38.3	9.5	37.3	37.3	40.0
R342	Existing	368512	4891540	762	S13	5262		37.9	37.9		36.6	36.6	40.0
R347	Existing	357871	4889681	1308	S01	5581		30.6	30.6		29.3	29.3	40.0
R348	Existing	360487	4890950	877	S04	2786	15.8	36.5	36.5	14.8	35.2	35.3	40.0

Noise Receptor ID	Description	UTM NAD 83, Zone 18		Nearest Source Distance [m]			Sound Pressure [dBA]						Limit
				WTG		Sub- station	POR at 4.5 m			POR at 1.5 within 30 m			
		X	Y	Distance	ID	Distance	Substation	WTGs	Total	Substation	WTGs	Total	
R349	Existing	363772	4888688	867	S36	2460	16.4	38.3	38.3	15.4	36.8	36.9	40.0
R350	Existing	366311	4893115	750	S30	3651	12.0	36.5	36.5	11.0	35.3	35.3	40.0
R351	Vacant	366775	4889715	717	S02	3768	9.9	38.0	38.1	9.1	36.9	36.9	40.0
R352	Vacant	369763	4892264	689	S33	6598		38.4	38.4		37.3	37.3	40.0
R353	Existing	359505	4890524	618	S29	3807	11.3	37.9	38.0	10.4	36.9	36.9	40.0
R354	Vacant	364781	4890839	1220	S37	1533	21.6	36.0	36.2	20.6	34.6	34.8	40.0
R355	Vacant	362901	4891871	1011	S31	859	34.7	33.7	37.2	32.7	32.4	35.6	40.0
R356	Vacant	362602	4887414	984	S11	3741	11.5	35.7	35.7	10.6	34.3	34.3	40.0
R357	Vacant	366748	4889709	712	S02	3745	10.0	38.2	38.2	9.1	37.0	37.0	40.0
R360	Vacant	360396	4890844	768	S04	2884	15.3	37.1	37.1	14.3	35.9	35.9	40.0
R362	Vacant	369716	4892234	686	S33	6547		38.5	38.5		37.5	37.5	40.0
R364	Existing	358796	4888349	1259	S01	5249		31.8	31.8		30.4	30.4	40.0
R365	Vacant	360797	4891118	798	S22	2472	17.4	36.6	36.7	16.4	35.3	35.4	40.0
R369	Existing	360965	4890937	558	S22	2310	22.7	39.1	39.2	20.1	38.1	38.2	40.0
R374	Existing	369808	4893889	1046	S28	7111		34.4	34.4		33.1	33.1	40.0
R375	Existing	357788	4889639	1387	S01	5671		30.1	30.1		28.8	28.8	40.0
R380	Existing	362677	4891770	813	S31	897	34.2	35.0	37.7	32.2	33.8	36.1	40.0
R386	Existing	364270	4890005	947	S19	1480	21.1	37.9	38.0	20.0	36.5	36.6	40.0
R387	Existing	366670	4893402	591	S30	4109	10.2	37.9	37.9	9.3	36.9	36.9	40.0
R389	Vacant	361023	4891249	729	S22	2252	23.0	36.8	37.0	17.7	35.7	35.8	40.0
R390	Vacant	364033	4889676	743	S34	1612	20.2	38.7	38.7	19.3	37.3	37.3	40.0
R393	Vacant	368197	4894190	1388	S28	5819		33.2	33.2		31.8	31.8	40.0
R394	Existing	359641	4890604	699	S29	3661	11.9	37.4	37.4	11.0	36.3	36.3	40.0
R396	Existing	361426	4891626	970	S22	1918	25.1	35.1	35.5	19.7	33.8	34.0	40.0
R401	Vacant	366899	4893486	564	S30	4346	13.6	38.2	38.3	10.7	37.3	37.3	40.0
R405	Existing	362809	4886297	1480	S11	4820	7.7	31.6	31.6	7.0	30.3	30.3	40.0
R407	Existing	360590	4891007	926	S22	2681	16.3	36.4	36.5	15.4	35.1	35.1	40.0
R411	Existing	362360	4892437	1408	S31	1620	27.1	31.1	32.5	24.7	29.8	31.0	40.0

Noise Receptor ID	Description	UTM NAD 83, Zone 18		Nearest Source Distance [m]			Sound Pressure [dBA]						Limit
				WTG		Sub- station	POR at 4.5 m			POR at 1.5 within 30 m			
		X	Y	Distance	ID	Distance	Substation	WTGs	Total	Substation	WTGs	Total	
R412	Existing	367587	4890848	855	S14	4325	9.4	38.1	38.1	4.1	36.8	36.8	40.0
R415	Existing	360594	4891137	980	S22	2676	16.3	35.6	35.7	15.4	34.1	34.1	40.0
R416	Existing	362577	4891721	731	S31	933	33.8	35.7	37.9	31.7	34.6	36.4	40.0
R417	Existing	362565	4887449	956	S11	3713	11.6	35.9	36.0	10.7	34.6	34.6	40.0
R420	Existing	368977	4891757	770	S12	5746		37.8	37.8		36.6	36.6	40.0
R421	Existing	361093	4891340	770	S22	2189	18.9	36.4	36.5	18.0	35.2	35.3	40.0
R422	Existing	368133	4894055	1334	S28	5693		33.9	33.9		32.5	32.5	40.0
R425	Existing	369291	4893952	849	S28	6665		35.9	35.9		34.7	34.7	40.0
R430	Vacant	359558	4890551	642	S29	3751	11.6	37.8	37.8	10.6	36.7	36.7	40.0
R431	Existing	366520	4893262	611	S30	3906	11.0	37.7	37.7	10.0	36.7	36.7	40.0
R433	Vacant	361494	4891408	754	S22	1803	25.8	37.0	37.3	23.2	35.9	36.1	40.0
R436	Existing	362930	4891822	987	S31	802	35.4	33.9	37.7	33.5	32.6	36.1	40.0
R439	Existing	365949	4889171	817	S37	3299	7.1	38.7	38.7	5.8	37.5	37.5	40.0
R440	Vacant	367787	4893861	1185	S30	5297		34.7	34.7		33.3	33.3	40.0
R447	Existing	360700	4891163	903	S22	2570	16.8	35.9	35.9	15.9	34.3	34.3	40.0
R450	Existing	367116	4890118	676	S02	3969	7.3	38.1	38.1	6.4	36.9	37.0	40.0
R454	Existing	368019	4891231	644	S13	4752	4.7	38.6	38.6	1.7	37.5	37.5	40.0
R459	Existing	367339	4893889	995	S30	4936	7.4	33.7	33.7	6.6	32.5	32.5	40.0
R460	Existing	358748	4890166	747	S01	4616	8.4	36.5	36.5	7.7	35.4	35.4	40.0
R462	Vacant	360797	4891042	755	S22	2472	21.8	37.1	37.2	16.4	35.9	35.9	40.0
R464	Vacant	367916	4891122	726	S13	4647	8.3	38.2	38.2	2.7	37.0	37.0	40.0
R465	Vacant	359201	4888621	931	S01	4762	7.9	34.3	34.3	7.1	33.0	33.0	40.0
R466	Existing	361721	4886415	794	S11	4930	7.4	36.4	36.4	6.6	35.3	35.3	40.0
R467	Existing	363656	4888940	822	S20	2190	17.6	38.9	38.9	16.7	37.5	37.6	40.0
R468	Existing	360663	4891152	928	S22	2607	16.7	35.8	35.8	15.7	34.2	34.2	40.0
R470	Vacant	366861	4893464	553	S30	4303	13.8	38.4	38.4	10.8	37.5	37.5	40.0
R473	Vacant	360111	4889023	1042	S29	3777	11.3	36.3	36.3	10.4	34.9	34.9	40.0
R474	Existing	359973	4890759	810	S04	3314	13.4	36.8	36.8	12.5	35.6	35.6	40.0

Noise Receptor ID	Description	UTM NAD 83, Zone 18		Nearest Source Distance [m]			Sound Pressure [dBA]						Limit
				WTG		Sub- station	POR at 4.5 m			POR at 1.5 within 30 m			
		X	Y	Distance	ID	Distance	Substation	WTGs	Total	Substation	WTGs	Total	
R476	Existing	362890	4887884	1021	S05	3234	13.4	36.3	36.3	12.6	34.9	34.9	40.0
R477	Existing	366920	4893657	726	S30	4460	13.2	36.4	36.4	8.2	35.2	35.2	40.0
R478	Existing	360615	4891158	972	S22	2655	16.4	35.6	35.6	15.4	34.0	34.1	40.0
R479	Existing	360802	4891262	885	S22	2473	17.4	35.6	35.7	16.4	34.2	34.2	40.0
R480	Existing	359029	4890238	626	S29	4326	9.4	38.3	38.3	8.6	37.3	37.3	40.0
R481	Existing	367777	4893927	1231	S30	5323		34.3	34.3		32.9	32.9	40.0
R483	Existing	360249	4889075	1014	S04	3634	11.8	36.4	36.4	10.9	35.0	35.0	40.0
R487	Existing	361390	4886229	978	S09	5217		35.3	35.3		34.1	34.1	40.0
R488	Existing	362754	4887614	1186	S11	3520	12.3	35.6	35.6	11.4	34.1	34.1	40.0
R493	Existing	363947	4889535	722	S34	1701	19.7	38.9	38.9	18.9	37.5	37.6	40.0
R498	Vacant	368372	4894049	1169	S28	5896		34.2	34.2		32.9	32.9	40.0
R502	Vacant	369943	4892403	728	S33	6800		37.5	37.5		36.4	36.4	40.0
R507	Existing	362913	4891806	964	S31	795	35.5	34.0	37.8	33.6	32.7	36.2	40.0
R508	Vacant	367543	4893804	999	S30	5060		35.2	35.2		33.8	33.8	40.0
R509	Vacant	360379	4890888	812	S04	2898	15.2	36.7	36.8	14.2	35.5	35.5	40.0
R511	Existing	366940	4893673	739	S30	4486	13.1	36.2	36.3	8.1	35.1	35.1	40.0
R514	Existing	361461	4886275	947	S11	5148		35.7	35.7		34.5	34.5	40.0
R516	Existing	364116	4889770	802	S34	1573	20.4	38.4	38.5	19.5	37.0	37.1	40.0
R517	Existing	368681	4894038	998	S28	6160		34.9	34.9		33.6	33.6	40.0
R518	Existing	359892	4890709	817	S04	3399	13.0	37.0	37.0	12.1	35.8	35.8	40.0
R519	Existing	367020	4890008	643	S02	3905	7.7	38.3	38.3	6.5	37.2	37.2	40.0
R522	Existing	359403	4890491	603	S29	3913	10.9	38.0	38.0	10.1	37.0	37.0	40.0
R523	Existing	361324	4891465	818	S22	1980	24.7	36.1	36.4	22.1	34.9	35.1	40.0
R524	Existing	361123	4891395	807	S22	2167	19.1	36.0	36.1	18.2	34.8	34.9	40.0
R525	Existing	359206	4890382	592	S29	4125	10.1	38.2	38.2	9.3	37.3	37.3	40.0
R526	Existing	362022	4891479	553	S31	1305	29.6	38.3	38.9	24.3	37.4	37.6	40.0
R527	Existing	361306	4891547	902	S22	2014	20.0	35.4	35.5	19.1	34.1	34.2	40.0
R528	Existing	367900	4894004	1368	S30	5468		33.9	33.9		32.5	32.5	40.0

Noise Receptor ID	Description	UTM NAD 83, Zone 18		Nearest Source Distance [m]			Sound Pressure [dBA]						Limit
				WTG		Sub- station n	POR at 4.5 m			POR at 1.5 within 30 m			
		X	Y	Distance	ID	Distance	Substation	WTGs	Total	Substation	WTGs	Total	
R531	Vacant	358037	4889756	1153	S01	5400		31.8	31.8		30.5	30.5	40.0
R532	Vacant	366125	4889308	829	S37	3369	7.8	38.7	38.7	6.4	37.5	37.5	40.0
R533	Existing	359064	4890367	676	S29	4268	9.6	37.4	37.4	8.8	36.3	36.3	40.0
R538	Existing	360529	4890971	903	S04	2743	16.0	36.5	36.5	15.1	35.1	35.2	40.0
R540	Vacant	358752	4890104	694	S01	4624	8.4	36.9	36.9	7.6	35.9	35.9	40.0
R541	Existing	359436	4890475	580	S29	3883	11.1	38.3	38.3	10.2	37.3	37.3	40.0
R545	Vacant	365229	4887408	1178	S36	4176	8.6	33.0	33.1	7.9	31.7	31.7	40.0
R547	Existing	360683	4891197	937	S22	2589	16.7	35.5	35.6	15.8	34.0	34.0	40.0
R549	Existing	360940	4891214	754	S22	2332	18.1	36.7	36.7	17.2	35.5	35.6	40.0
R551	Existing	357981	4889730	1204	S01	5462		31.4	31.4		30.1	30.1	40.0
R552	Existing	359148	4888646	906	S01	4794	7.8	34.4	34.4	7.0	33.1	33.2	40.0
R555	Existing	363019	4888085	870	S05	3020	14.3	37.1	37.2	13.4	35.8	35.8	40.0
R560	Existing	366733	4889671	743	S02	3745	9.9	38.0	38.0	9.1	36.8	36.8	40.0
R562	Existing	359240	4890437	618	S29	4082	10.3	37.8	37.8	9.5	36.8	36.8	40.0
R565	Existing	368500	4894374	1380	S28	6174		32.5	32.5		31.1	31.1	40.0
R568	Vacant	367503	4893727	913	S30	4985	11.4	35.7	35.8	8.5	34.4	34.5	40.0
R569	Vacant	358913	4890177	677	S01	4452	9.0	37.8	37.8	8.2	36.8	36.8	40.0
R570	Existing	367045	4893676	735	S30	4573	12.8	36.4	36.4	9.9	35.3	35.3	40.0
R571	Vacant	364037	4889790	721	S34	1514	20.7	38.6	38.6	19.8	37.2	37.3	40.0
R574	Vacant	361281	4891427	789	S22	2016	24.4	36.3	36.6	21.8	35.1	35.3	40.0
R576	Existing	361477	4891672	1017	S22	1882	25.3	34.9	35.3	22.8	33.6	33.9	40.0
R581	Existing	357958	4889741	1229	S01	5482		31.2	31.2		29.9	29.9	40.0
R582	Existing	368198	4891377	603	S13	4937	4.3	38.9	38.9	3.1	37.8	37.8	40.0
R584	Existing	359512	4890469	563	S29	3809	11.3	38.6	38.6	10.4	37.7	37.7	40.0
R585	Existing	362088	4891716	733	S31	1334	24.9	35.9	36.2	24.1	34.4	34.8	40.0
R587	Existing	367153	4893734	801	S30	4696	12.4	35.9	35.9	7.4	34.7	34.7	40.0
R590	Existing	369626	4893805	864	S28	6910		36.0	36.0		34.8	34.8	40.0
R593	Existing	360756	4891210	885	S22	2515	17.1	35.7	35.8	16.3	34.3	34.3	40.0

Noise Receptor ID	Description	UTM NAD 83, Zone 18		Nearest Source Distance [m]			Sound Pressure [dBA]						Limit
				WTG		Sub- station n	POR at 4.5 m			POR at 1.5 within 30 m			
		X	Y	Distance	ID	Distance	Substation	WTGs	Total	Substation	WTGs	Total	
R602	Existing	362078	4891512	552	S31	1262	30.0	38.2	38.8	24.7	37.3	37.5	40.0
R604	Vacant	359924	4888947	964	S01	3976	10.5	36.1	36.1	9.7	34.8	34.8	40.0
R607	Existing	364312	4889960	888	S19	1542	20.8	38.1	38.2	19.7	36.8	36.8	40.0
R608	Vacant	369253	4891943	656	S12	6044		38.8	38.8		37.7	37.7	40.0
R609	Vacant	369303	4891969	659	S12	6097		38.9	38.9		37.8	37.8	40.0
R610	Vacant	362241	4886993	637	S11	4230	9.7	37.6	37.6	8.9	36.6	36.6	40.0
R611	Vacant	363447	4891985	1460	S31	907	29.3	32.0	33.9	28.8	30.6	32.8	40.0
R612	Existing	359317	4890473	614	S29	4001	10.6	37.8	37.8	9.7	36.8	36.8	40.0
R613	Existing	358798	4888273	1332	S01	5287		31.4	31.4		30.1	30.1	40.0
R614	Vacant	366592	4889595	785	S02	3646	10.1	38.2	38.2	9.2	37.0	37.0	40.0
R615	Existing	366692	4889634	766	S02	3722	9.9	37.9	37.9	9.1	36.7	36.7	40.0
R616	Vacant	366974	4889878	693	S02	3900	9.7	37.9	37.9	7.4	36.7	36.7	40.0
R619	Existing	364846	4890591	986	S37	1655	21.3	37.3	37.4	20.2	36.0	36.1	40.0
R620	Existing	362854	4891844	962	S31	856	34.7	34.0	37.4	32.8	32.7	35.7	40.0
R622	Vacant	366374	4893149	698	S30	3722	11.7	36.9	36.9	10.7	35.8	35.8	40.0
R623	Vacant	361623	4891448	811	S22	1683	26.7	37.0	37.3	24.2	35.8	36.1	40.0
R625	Existing	362841	4891878	984	S31	892	34.3	33.8	37.1	32.3	32.5	35.4	40.0
R626	Existing	362457	4891736	716	S31	1034	32.2	35.9	37.5	30.0	34.8	36.1	40.0
R627	Vacant	362715	4887724	1158	S05	3416	12.7	36.0	36.0	11.9	34.6	34.6	40.0
R632	Existing	367413	4893773	913	S30	4934	11.6	35.5	35.5	8.7	34.2	34.2	40.0
R633	Existing	362614	4891873	887	S31	1017	27.9	34.0	35.0	27.9	32.5	33.8	40.0
R636	Existing	360541	4891112	1014	S22	2728	16.0	35.6	35.6	15.1	34.1	34.1	40.0
R637	Existing	361463	4886045	1174	S11	5363		33.7	33.7		32.5	32.5	40.0
R638	Vacant	367596	4893832	1051	S30	5119		35.0	35.0		33.6	33.6	40.0
R641	Existing	361144	4891459	858	S22	2156	19.1	35.2	35.3	18.2	34.0	34.2	40.0
R643	Existing	361178	4891489	875	S22	2127	19.3	35.0	35.2	18.4	33.9	34.0	40.0
R670	Existing	361834	4891347	600	S31	1457	28.4	38.5	38.9	26.0	37.5	37.8	40.0
R673	Existing	366974	4890051	582	S02	3849	9.6	39.0	39.0	6.7	37.9	37.9	40.0

Noise Receptor ID	Description	UTM NAD 83, Zone 18		Nearest Source Distance [m]			Sound Pressure [dBA]						Limit
				WTG		Sub- station n	POR at 4.5 m			POR at 1.5 within 30 m			
		X	Y	Distance	ID	Distance	Substation	WTGs	Total	Substation	WTGs	Total	
R693	Existing	361775	4886598	622	S11	4739	8.0	38.1	38.1	7.2	37.1	37.1	40.0
R694	Existing	358435	4889082	874	S01	5237		33.9	33.9		32.8	32.8	40.0
R695	Existing	359183	4890360	589	S29	4152	10.0	38.3	38.3	9.2	37.3	37.3	40.0
R696	Existing	359353	4890487	615	S29	3963	10.8	37.8	37.8	9.9	36.8	36.8	40.0
R697	Existing	359774	4890703	822	S29	3517	12.5	36.8	36.8	11.6	35.5	35.6	40.0
R698	Existing	360402	4890935	859	S04	2872	15.3	36.4	36.5	14.4	35.1	35.2	40.0
R699	Existing	362107	4891706	717	S31	1313	25.1	35.9	36.2	24.2	34.6	35.0	40.0
R700	Existing	362391	4892427	1399	S31	1595	27.3	31.2	32.7	24.9	29.9	31.1	40.0
R708	Existing	365565	4893159	1491	S30	3087	18.7	32.3	32.5	13.5	30.9	31.0	40.0
R709	Vacant	364932	4890605	942	S37	1734	20.8	37.6	37.7	19.7	36.3	36.4	40.0
R710	Existing	364665	4890379	928	S19	1568	21.4	37.7	37.8	20.3	36.3	36.4	40.0
R711	Vacant	362959	4888080	853	S05	3032	14.2	37.2	37.3	13.4	35.9	35.9	40.0
R712	Existing	362837	4886350	1471	S11	4765	7.9	31.7	31.7	7.1	30.3	30.4	40.0
R723	Existing	366870	4893610	690	S30	4392	13.4	36.7	36.7	8.3	35.6	35.6	40.0
R724	Existing	367973	4891218	643	S13	4705	4.7	38.7	38.7	1.5	37.6	37.6	40.0
R725	Vacant	369414	4893893	831	S28	6751		36.1	36.1		34.9	34.9	40.0
R726	Existing	368834	4894356	1255	S28	6450		32.8	32.8		31.5	31.5	40.0
R727	Existing	366503	4892626	622	S30	3578	12.0	39.1	39.1	11.0	38.0	38.0	40.0
R728	Existing	367118	4890143	669	S02	3964	7.2	38.2	38.2	6.4	37.1	37.1	40.0
R730	Existing	366481	4889550	821	S27	3564	10.1	38.5	38.5	6.1	37.2	37.3	40.0
R731	Existing	366491	4889566	807	S02	3566	10.2	38.5	38.5	9.2	37.3	37.3	40.0

Table C.2 Noise Impact Summary – Participating Project Noise Receptors (44 receptors)

The table is sorted by noise receptors ID; “Vacant” = vacant lot noise receptor, “Existing” = existing dwelling; “Total” = combined contribution from all sources (substation and WTGs); blank cells in “Sound pressure” columns = POR at more than 5000 m from source.

Noise Receptor ID	Description	UTM NAD 83, zone 18		Nearest Source Distance [m]			Sound Pressure [dBA]					
				WTG		Sub-station	POR at 4.5 m			POR at 1.5 within 30 m		
		X	Y	Distance	ID	Distance	Substation	WTGs	Total	Substation	WTGs	Total
R015	Existing	365758	4889070	816	S19	3208	7.0	39.1	39.1	5.8	37.9	37.9
R039	Vacant	359608	4888818	853	S01	4312	9.4	35.8	35.8	8.6	34.5	34.5
R044	Vacant	362910	4890438	679	S34	749	28.4	38.7	39.1	27.1	37.4	37.8
R048	Vacant	362789	4890459	724	S31	797	28.3	38.7	39.1	27.4	37.2	37.7
R076	Vacant	361163	4889513	869	S16	2635	15.8	38.0	38.0	14.9	36.5	36.6
R115	Vacant	365282	4888463	696	S36	3314	9.5	39.1	39.1	8.7	38.0	38.0
R134	Existing	367322	4890451	836	S02	4104	6.2	37.9	37.9	4.7	36.7	36.7
R140	Existing	363261	4892098	1410	S31	1002	28.0	31.8	33.3	28.1	30.5	32.5
R156	Vacant	358969	4890147	630	S01	4403	9.2	38.6	38.6	8.3	37.7	37.7
R177	Existing	366495	4889660	712	S02	3531	10.3	39.2	39.2	9.4	38.0	38.0
R179	Vacant	366131	4889365	798	S37	3345	8.7	39.0	39.1	6.5	37.9	37.9
R211	Vacant	362482	4890207	834	S31	1187	23.3	38.7	38.8	22.4	37.2	37.4
R224	Vacant	365458	4888627	710	S21	3300	9.6	38.6	38.6	8.8	37.4	37.4
R248	Vacant	363980	4889192	913	S21	2032	18.2	38.8	38.8	17.2	37.3	37.3
R250	Vacant	361864	4886650	599	S11	4662	8.3	38.2	38.2	7.5	37.2	37.2
R254	Existing	360129	4890712	694	S04	3163	14.0	37.7	37.7	13.1	36.5	36.6
R255	Vacant	360406	4889168	908	S04	3452	12.5	36.8	36.8	11.6	35.4	35.4
R297	Existing	365371	4888610	651	S21	3255	9.6	39.2	39.2	8.8	38.0	38.0
R310	Existing	363457	4892030	1498	S31	953	28.8	31.8	33.6	28.3	30.5	32.5
R328	Vacant	363066	4891848	1093	S31	779	35.7	33.3	37.7	30.8	32.0	34.5
R337	Existing	368133	4891327	605	S13	4869	4.7	38.9	38.9	2.9	37.8	37.8
R373	Existing	369538	4892176	661	S33	6361		39.5	39.5		38.5	38.5
R376	Existing	362412	4889866	783	S20	1499	21.6	39.5	39.6	20.6	38.2	38.2
R383	Existing	367296	4890391	807	S02	4088	6.5	37.9	37.9	4.3	36.6	36.6
R399	Vacant	369451	4892050	690	S12	6255		38.9	38.9		37.8	37.8
R427	Vacant	361304	4891372	730	S22	1984	24.6	36.9	37.2	22.0	35.8	35.9

Noise Receptor ID	Description	UTM NAD 83, zone 18		Nearest Source Distance [m]			Sound Pressure [dBA]					
				WTG		Sub-station	POR at 4.5 m			POR at 1.5 within 30 m		
		X	Y	Distance	ID	Distance	Substation	WTGs	Total	Substation	WTGs	Total
R435	Vacant	363314	4888993	492	S20	2103	18.1	41.6	41.7	17.2	40.7	40.7
R441	Existing	361668	4886460	746	S11	4904	7.5	37.0	37.0	6.7	35.9	35.9
R457	Existing	365771	4889428	504	S37	3006	14.4	41.9	41.9	13.5	40.9	40.9
R463	Vacant	361867	4889920	848	S22	1830	19.5	38.8	38.8	18.4	37.3	37.4
R503	Vacant	363155	4888902	434	S20	2197	17.8	43.0	43.1	16.9	42.3	42.3
R505	Existing	367415	4890605	834	S14	4175	9.9	38.0	38.0	4.9	36.7	36.7
R537	Vacant	366953	4893452	519	S30	4374	13.5	38.9	38.9	10.6	38.0	38.1
R556	Existing	366391	4889653	684	S27	3439	10.4	39.7	39.7	9.5	38.6	38.6
R573	Vacant	363517	4891934	1483	S31	875	29.7	32.0	34.0	29.2	30.7	33.0
R577	Vacant	359041	4890166	581	S29	4329	9.4	39.1	39.1	8.6	38.2	38.2
R578	Vacant	365567	4888834	716	S21	3224	13.3	38.9	38.9	9.0	37.7	37.7
R598	Existing	360680	4889284	838	S04	3160	13.6	37.2	37.2	12.7	35.9	35.9
R600	Existing	362831	4891653	793	S31	709	36.7	35.3	39.0	34.4	34.1	37.2
R618	Existing	363401	4892017	1448	S31	931	29.1	31.9	33.7	28.5	30.6	32.7
R667	Vacant	361446	4889693	781	S16	2300	17.3	38.5	38.6	16.3	37.1	37.2
R678	Vacant	364467	4889566	640	S19	1943	18.7	40.2	40.2	17.6	39.0	39.0
R701	Existing	363294	4892136	1460	S31	1041	27.6	31.7	33.1	27.0	30.3	32.0
R720	Vacant	363943	4889237	907	S34	1977	18.5	38.8	38.8	17.6	37.3	37.3

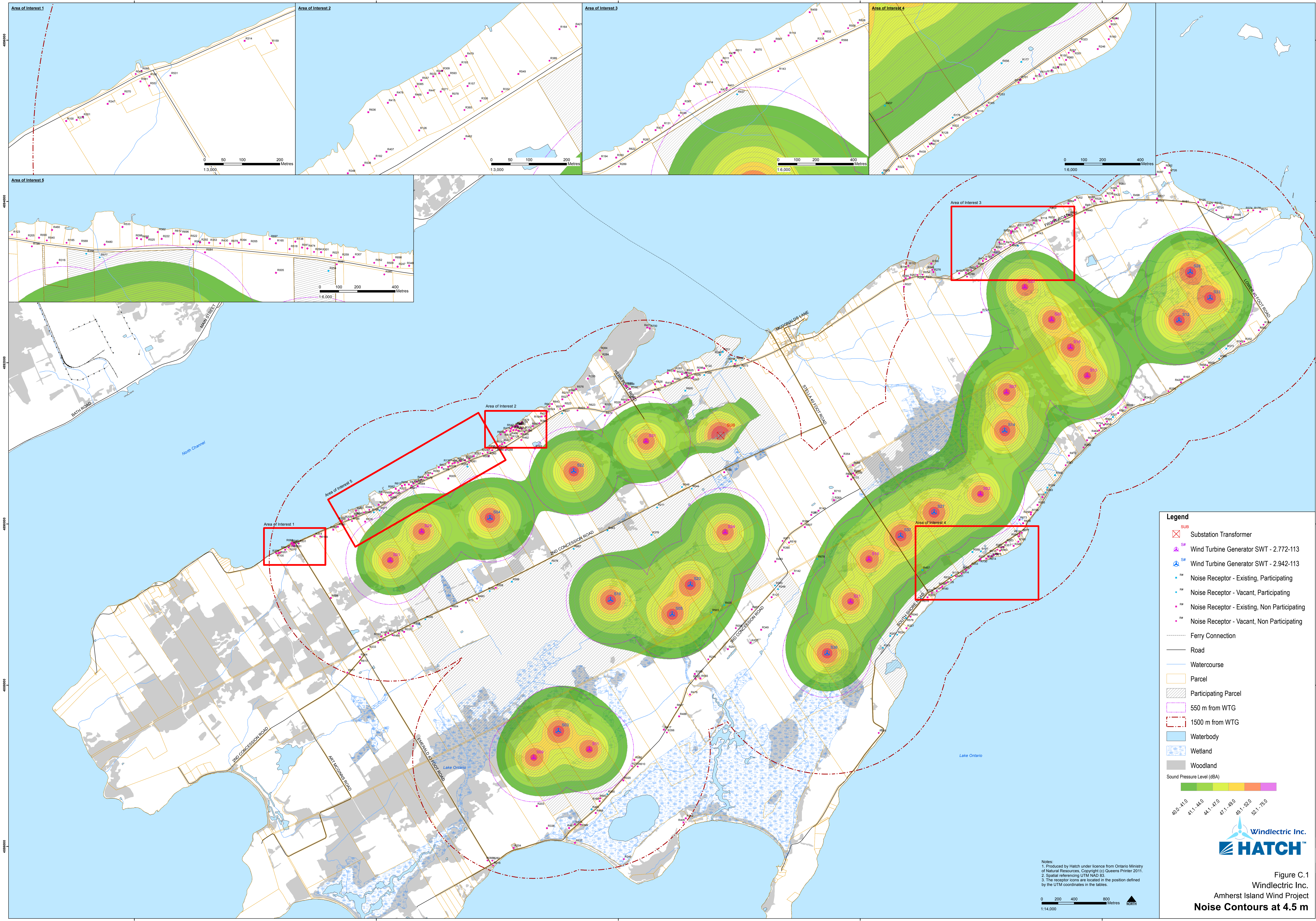

Legend

- Substation Transformer
- Wind Turbine Generator SWT - 2.772-113
- Wind Turbine Generator SWT - 2.942-113
- Noise Receptor - Existing, Participating
- Noise Receptor - Vacant, Participating
- Noise Receptor - Existing, Non Participating
- Noise Receptor - Vacant, Non Participating
- Ferry Connection
- Road
- Watercourse
- Parcel
- Participating Parcel
- 550 m from WTG
- 1500 m from WTG
- Waterbody
- Wetland
- Woodland

Sound Pressure Level (dBA)

40.0 - 41.0 41.1 - 44.0 44.1 - 47.0 47.1 - 49.0 49.1 - 52.0 52.1 - 75.0

Notes:
 1. Produced by Hatch under licence from Ontario Ministry of Natural Resources, Copyright (c) Queens Printer 2011.
 2. Spatial referencing UTM NAD 83.
 3. The receptor icons are located in the position defined by the UTM coordinates in the tables.



Figure C.1
 Windtetric Inc.
 Amherst Island Wind Project
 Noise Contours at 4.5 m

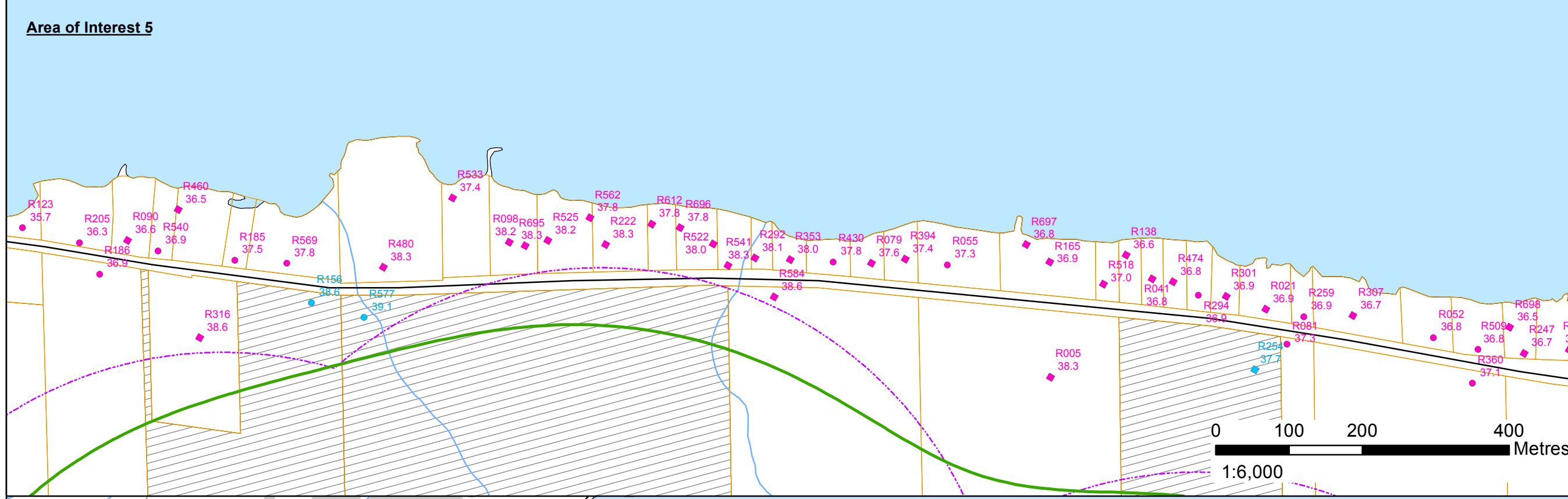
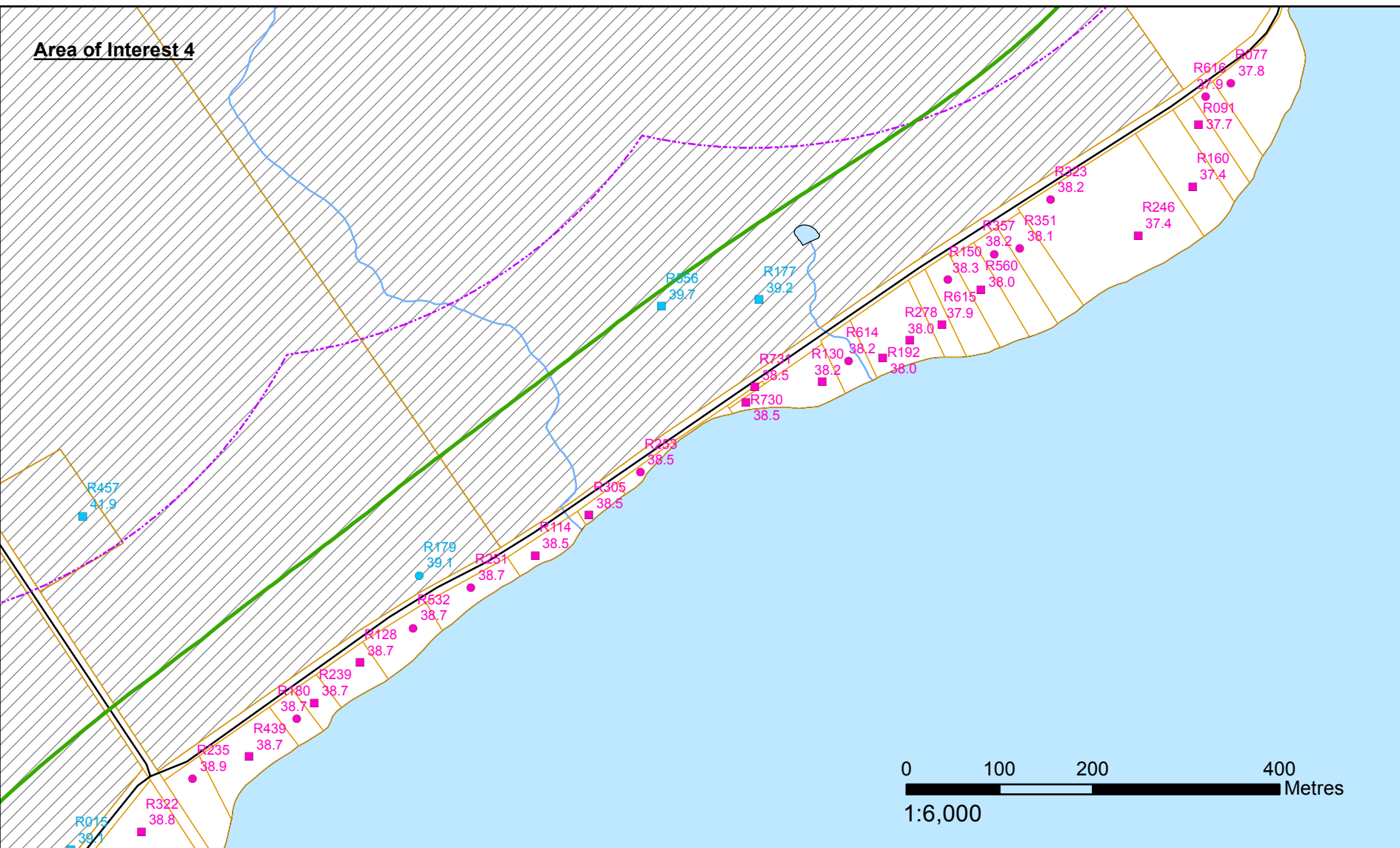
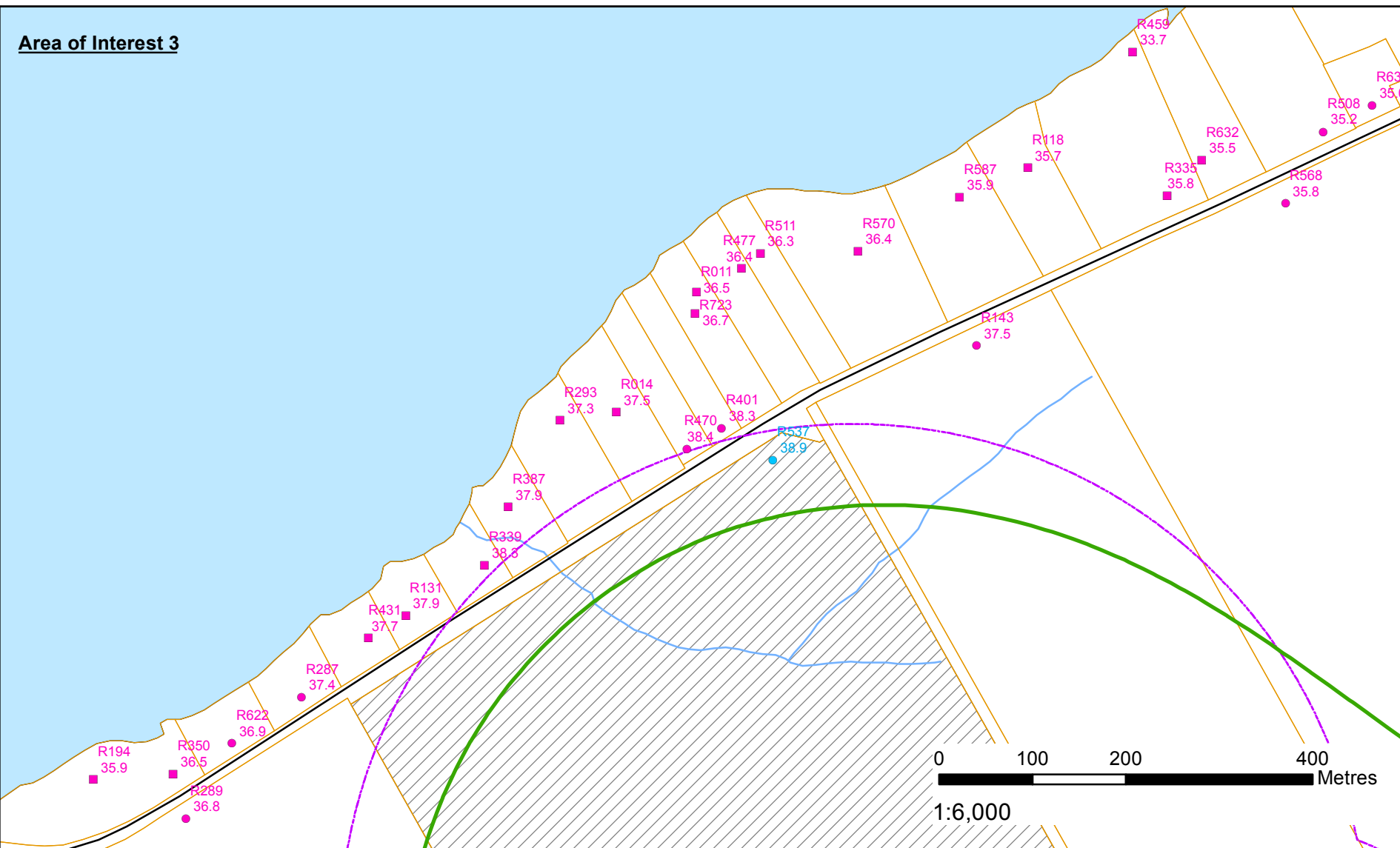
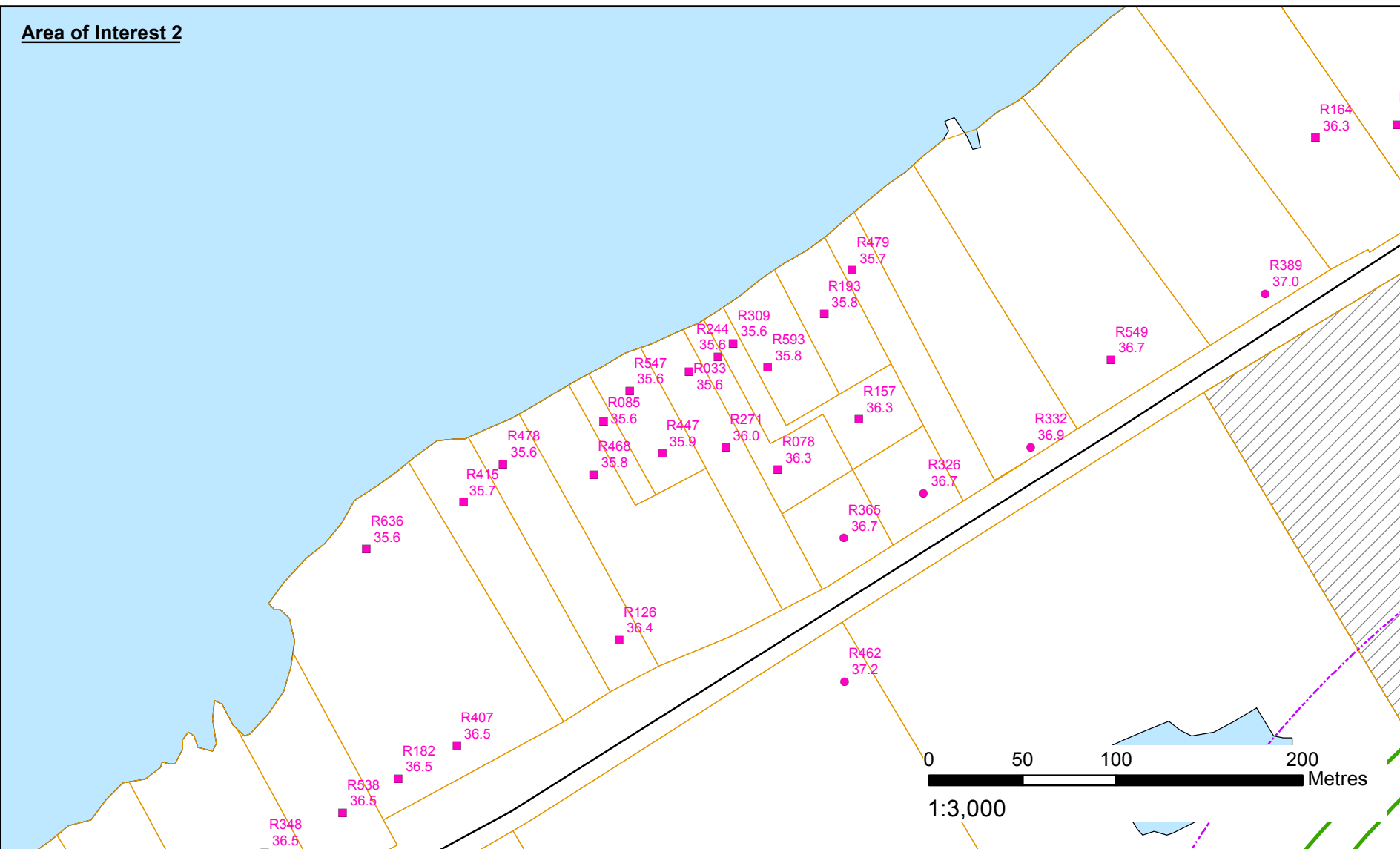
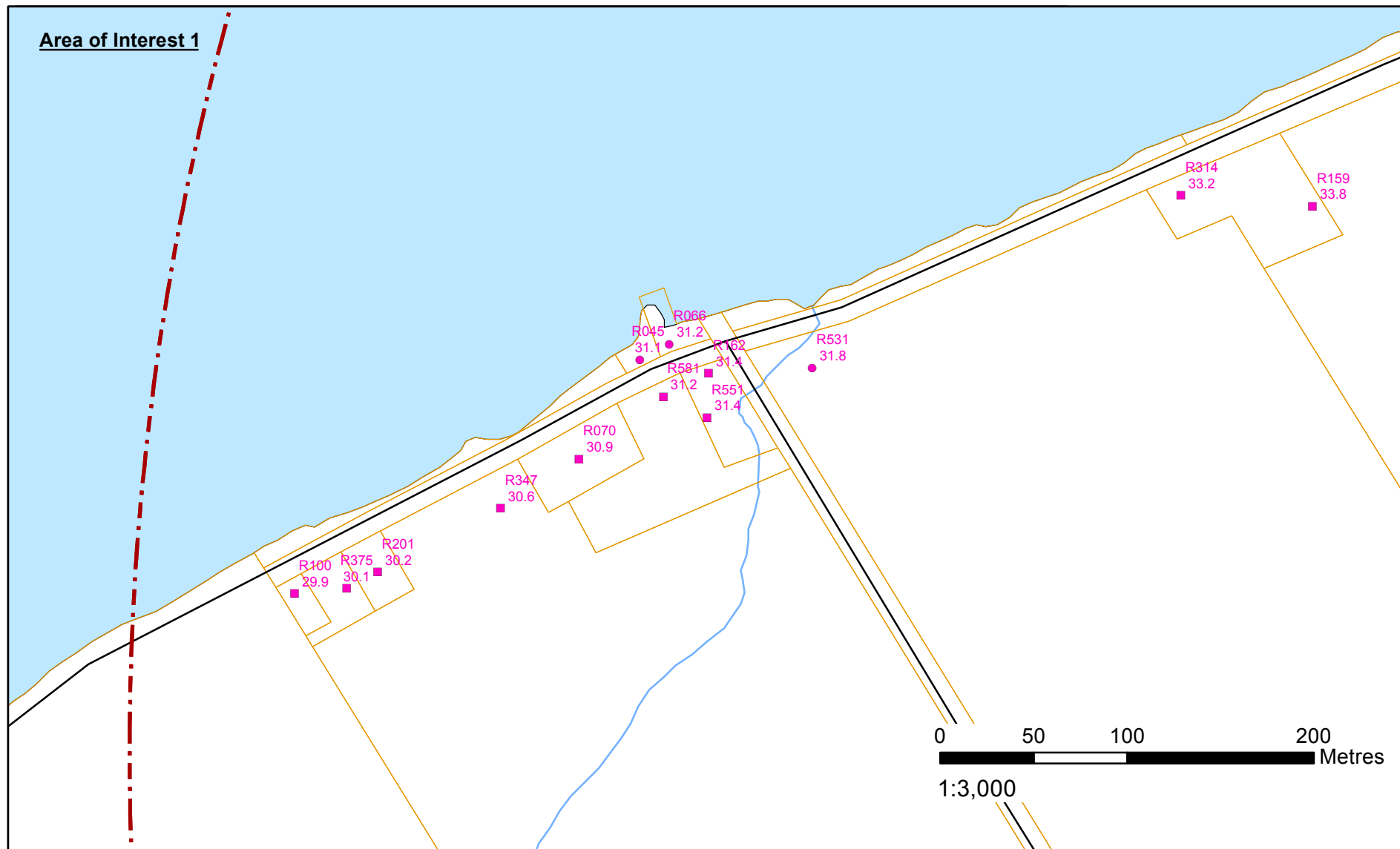
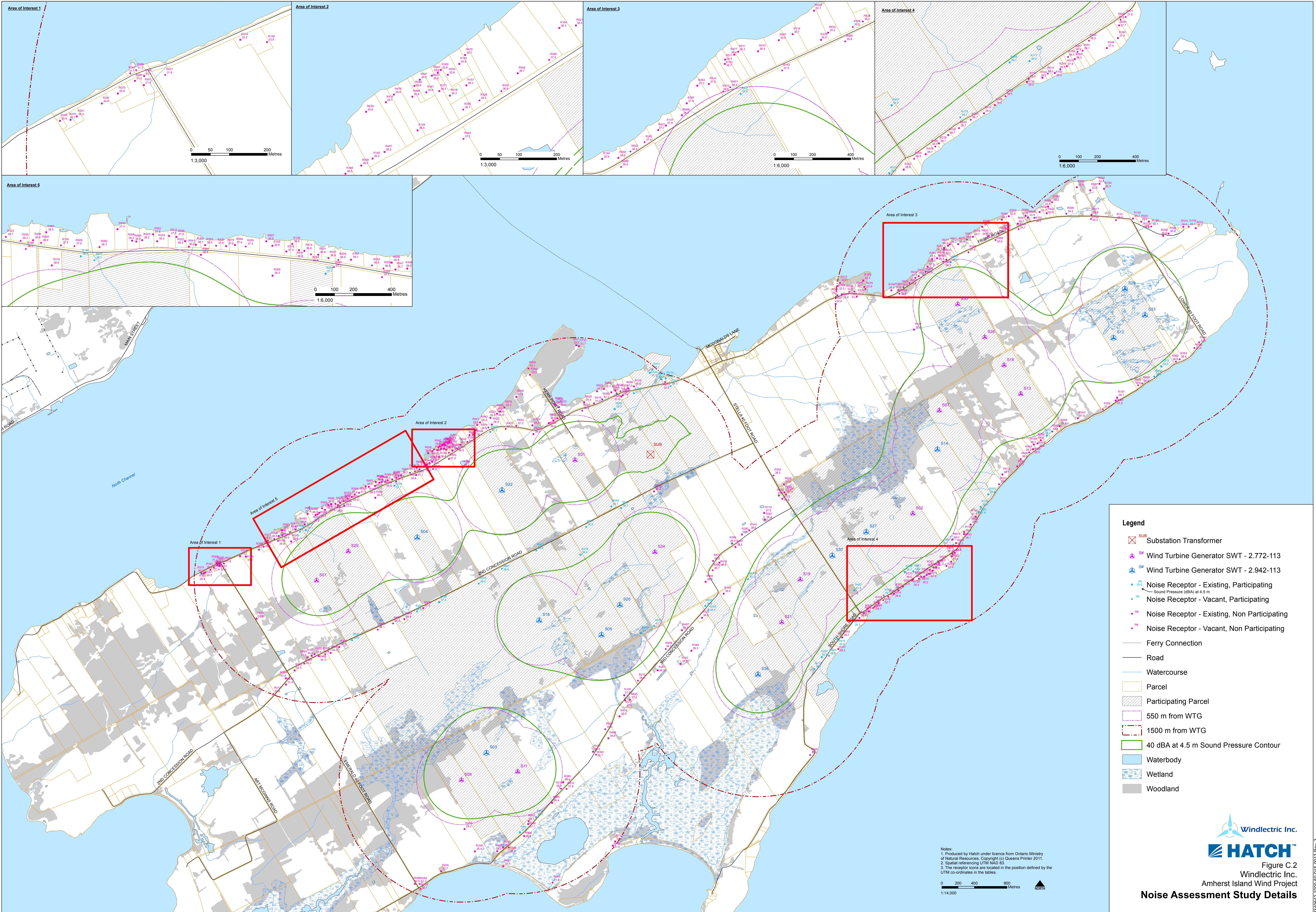

- Legend**
- Substation Transformer
 - Wind Turbine Generator SWT - 2.772-113
 - Wind Turbine Generator SWT - 2.942-113
 - Noise Receptor - Existing, Participating
Sound Pressure (dBA) at 4.5 m
 - Noise Receptor - Vacant, Participating
 - Noise Receptor - Existing, Non Participating
 - Noise Receptor - Vacant, Non Participating
 - Ferry Connection
 - Road
 - Watercourse
 - Parcel
 - Participating Parcel
 - 550 m from WTG
 - 1500 m from WTG
 - 40 dBA at 4.5 m Sound Pressure Contour
 - Waterbody
 - Wetland
 - Woodland

Notes:
 1. Produced by Hatch under licence from Ontario Ministry of Natural Resources. Copyright (c) Queens Printer 2011.
 2. Spatial referencing UTM NAD 83.
 3. The receptor icons are located in the position defined by the UTM co-ordinates in the tables.

0 200 400 800 Metres
 1:14,000

Appendix D

CADNA-A Sample Calculation and Verification

Calculation of Sound Pressure Levels from Wind Turbine using ISO 9613-2

Amherst Island Wind Project

Background

As requested by the Ministry of Environment in the Noise Guidelines for Wind Farms in Section 6.7 – Appendices (October 2008), a sample calculation should be included in the Noise Assessment Report. The sample calculation must include at least one detailed calculation for a source to point of reception “pair,” preferably addressing the closest wind turbine unit, and it must represent all other “pairs”.

For this project, a POR representing non-participating Noise Receptor R080 along with S11 turbine were chosen as a “pair”.

The calculations are based on ISO 9613-2: Acoustics – Attenuation of sound during propagation outdoors – General Method of Calculation. The ground attenuation coefficient was assumed as 0.7, as suggested by the MOE Guidelines (Section 6.4.10 – Specific Parameters). Ambient temperature and relative humidity were assumed at 10°C and 70%, respectively. The octave band data for the Siemens SWT-2.3-113 wind turbine generator were provided by the manufacturer and adjusted for wind shear. The octave band data used in this calculation is identical to that used in CADNA-A model.

Input parameters

POR height $h_r := 4.5\text{m}$

Noise source height $h_s := 99.5\text{m}$

Coordinates and elevation of R080 POR, Zr below included ground elevation and receptor height

$X_r := 362200.34\text{m}$ $Y_r := 4887074.70\text{m}$ $Z_r := 84.5\text{m}$

Coordinates and elevation of S11 noise source, Zr below included ground elevation and receptor height

$X_s := 361640.50\text{m}$ $Y_s := 4887205.50\text{m}$ $Z_s := 182.57\text{m}$

Ground absorption coefficient $G_a := 0.7$

Wind turbine (noise source) sound power emission

at 63 Hz	$L_{w_63} := 91.5\text{dBA}$
at 125 Hz	$L_{w_125} := 93.7\text{dBA}$
at 250 Hz	$L_{w_250} := 95.2\text{dBA}$
at 500 Hz	$L_{w_500} := 96.2\text{dBA}$
at 1000 Hz	$L_{w_1000} := 97.4\text{dBA}$
at 2000 Hz	$L_{w_2000} := 96.9\text{dBA}$
at 4000 Hz	$L_{w_4000} := 95.0\text{dBA}$
at 8000 Hz	$L_{w_8000} := 84.6\text{dBA}$

Distance from POR to source

$$d := \sqrt{(X_T - X_S)^2 + (Y_T - Y_S)^2 + (Z_T - Z_S)^2} = 583.2 \cdot \text{m} \quad \text{3D distance between the source and POR}$$

$$d_p := \sqrt{(X_T - X_S)^2 + (Y_T - Y_S)^2} = 574.9 \text{ m} \quad \text{Projected distance between the source and POR}$$

Combined sound power level for the source

$$\text{Total_L}_w := 10 \cdot \log \left(10^{\frac{L_{w_63}}{10}} + 10^{\frac{L_{w_125}}{10}} + 10^{\frac{L_{w_250}}{10}} + 10^{\frac{L_{w_500}}{10}} + 10^{\frac{L_{w_1000}}{10}} + 10^{\frac{L_{w_2000}}{10}} + 10^{\frac{L_{w_4000}}{10}} + 10^{\frac{L_{w_8000}}{10}} + \dots \right)$$

$$\text{Total_L}_w = 104 \cdot \text{dBA}$$

Attenuation

Attenuation due to geometrical divergence

$$\text{Att_div} := 20 \cdot \log\left(\frac{d}{1\text{m}}\right) + 11 = 66.3 \cdot \text{dB}$$

Attenuation due to atmospheric absorption at ambient temperature and relative humidity of 10°C and 70%

$$\text{at 63 Hz} \quad \text{Att_atm_63} := 0.1 \frac{\text{dB}}{\text{km}} \cdot d = 0.058 \cdot \text{dB}$$

$$\text{at 125 Hz} \quad \text{Att_atm_125} := 0.4 \frac{\text{dB}}{\text{km}} \cdot d = 0.233 \cdot \text{dB}$$

$$\text{at 250 Hz} \quad \text{Att_atm_250} := 1.0 \frac{\text{dB}}{\text{km}} \cdot d = 0.583 \cdot \text{dB}$$

$$\text{at 500 Hz} \quad \text{Att_atm_500} := 1.9 \frac{\text{dB}}{\text{km}} \cdot d = 1.108 \cdot \text{dB}$$

$$\text{at 1000 Hz} \quad \text{Att_atm_1000} := 3.7 \frac{\text{dB}}{\text{km}} \cdot d = 2.158 \cdot \text{dB}$$

$$\text{at 2000 Hz} \quad \text{Att_atm_2000} := 9.7 \frac{\text{dB}}{\text{km}} \cdot d = 5.657 \cdot \text{dB}$$

$$\text{at 4000 Hz} \quad \text{Att_atm_4000} := 32.8 \frac{\text{dB}}{\text{km}} \cdot d = 19.13 \cdot \text{dB}$$

$$\text{at 8000 Hz} \quad \text{Att_atm_8000} := 117.0 \frac{\text{dB}}{\text{km}} \cdot d = 68.237 \cdot \text{dB}$$

Attenuation coefficients

$$a_1(h) := 1.5 + 3.0 \cdot e^{-0.12 \left(\frac{h}{\text{m}} - 5\right)^2} \cdot \left(1 - e^{-\frac{d_p}{50 \cdot \text{m}}}\right) + 5.7 \cdot e^{-0.09 \cdot \frac{h^2}{\text{m}^2}} \cdot \left(1 - e^{-2.8 \cdot 10^{-6} \cdot \frac{d_p^2}{\text{m}^2}}\right)$$

$$b_1(h) := 1.5 + 8.6 \cdot e^{-0.09 \cdot \frac{h^2}{\text{m}^2}} \cdot \left(1 - e^{-\frac{d_p}{50 \cdot \text{m}}}\right)$$

$$c_1(h) := 1.5 + 14.0 \cdot e^{-0.46 \cdot \frac{h^2}{\text{m}^2}} \cdot \left(1 - e^{-\frac{d_p}{50 \cdot \text{m}}}\right)$$

$$d_1(h) := 1.5 + 5.0 \cdot e^{-0.9 \cdot \frac{h^2}{\text{m}^2}} \cdot \left(1 - e^{-\frac{d_p}{50 \cdot \text{m}}}\right)$$

$$q := \begin{cases} 0 & \text{if } d_p \leq 30 \cdot (h_r + h_s) \\ 1 - \frac{30 \cdot (h_r + h_s)}{d_p} & \text{otherwise} \end{cases}$$

Attenuation due to ground absorption - source

$$a_1(h_s) = 1.5 \quad b_1(h_s) = 1.5 \quad c_1(h_s) = 1.5 \quad d_1(h_s) = 1.5$$

at 63 Hz $Att_{gr_s_63} := -1.5 \text{ dB}$

at 125 Hz $Att_{gr_s_125} := -1.5 + G_a \cdot a_1(h_s) = -0.45 \text{ dB}$

at 250 Hz $Att_{gr_s_250} := -1.5 + G_a \cdot b_1(h_s) = -0.45 \text{ dB}$

at 500 Hz $Att_{gr_s_500} := -1.5 + G_a \cdot c_1(h_s) = -0.45 \text{ dB}$

at 1000 Hz $Att_{gr_s_1000} := -1.5 + G_a \cdot d_1(h_s) = -0.45 \text{ dB}$

at 2000 Hz $Att_{gr_s_2000} := -1.5 \cdot (1 - G_a) = -0.45 \text{ dB}$

at 4000 Hz $Att_{gr_s_4000} := -1.5 \cdot (1 - G_a) = -0.45 \text{ dB}$

at 8000 Hz $Att_{gr_s_8000} := -1.5 \cdot (1 - G_a) = -0.45 \text{ dB}$

Attenuation due to ground absorption - middle

$$q = 0$$

at 63 Hz $Att_{gr_m_63} := -3 \cdot q^2 = 0 \text{ dB}$

at 125 Hz $Att_{gr_m_125} := -3 \cdot q \cdot (1 - G_a) = 0 \text{ dB}$

at 250 Hz $Att_{gr_m_250} := -3 \cdot q \cdot (1 - G_a) = 0 \text{ dB}$

at 500 Hz $Att_{gr_m_500} := -3 \cdot q \cdot (1 - G_a) = 0 \text{ dB}$

at 1000 Hz $Att_{gr_m_1000} := -3 \cdot q \cdot (1 - G_a) = 0 \text{ dB}$

at 2000 Hz $Att_{gr_m_2000} := -3 \cdot q \cdot (1 - G_a) = 0 \text{ dB}$

at 4000 Hz $Att_{gr_m_4000} := -3 \cdot q \cdot (1 - G_a) = 0 \text{ dB}$

at 8000 Hz $Att_{gr_m_8000} := -3 \cdot q \cdot (1 - G_a) = 0 \text{ dB}$

Attenuation due to ground absorption - POR

$$a_1(h_r) = 4.967 \quad b_1(h_r) = 2.89 \quad c_1(h_r) = 1.501 \quad d_1(h_r) = 1.5$$

at 63 Hz $Att_{gr_r_63} := -1.5 \text{ dB}$

at 125 Hz $Att_{gr_r_125} := -1.5 + G_a \cdot a_1(h_r) = 1.977 \cdot \text{dB}$

at 250 Hz $Att_{gr_r_250} := -1.5 + G_a \cdot b_1(h_r) = 0.523 \cdot \text{dB}$

at 500 Hz $Att_{gr_r_500} := -1.5 + G_a \cdot c_1(h_r) = -0.449 \cdot \text{dB}$

at 1000 Hz $Att_{gr_r_1000} := -1.5 + G_a \cdot d_1(h_r) = -0.45 \cdot \text{dB}$

at 2000 Hz $Att_{gr_r_2000} := -1.5 \cdot (1 - G_a) = -0.45 \cdot \text{dB}$

at 4000 Hz $Att_{gr_r_4000} := -1.5 \cdot (1 - G_a) = -0.45 \cdot \text{dB}$

at 8000 Hz $Att_{gr_r_8000} := -1.5 \cdot (1 - G_a) = -0.45 \cdot \text{dB}$

Total ground attenuation for each frequency

at 63 Hz $Att_{gr_63} := Att_{gr_s_63} + Att_{gr_m_63} + Att_{gr_r_63} = -3 \cdot \text{dB}$

at 125 Hz $Att_{gr_125} := Att_{gr_s_125} + Att_{gr_m_125} + Att_{gr_r_125} = 1.5 \cdot \text{dB}$

at 250 Hz $Att_{gr_250} := Att_{gr_s_250} + Att_{gr_m_250} + Att_{gr_r_250} = 0.073 \cdot \text{dB}$

at 500 Hz $Att_{gr_500} := Att_{gr_s_500} + Att_{gr_m_500} + Att_{gr_r_500} = -0.9 \cdot \text{dB}$

at 1000 Hz $Att_{gr_1000} := Att_{gr_s_1000} + Att_{gr_m_1000} + Att_{gr_r_1000} = -0.9 \cdot \text{dB}$

at 2000 Hz $Att_{gr_2000} := Att_{gr_s_2000} + Att_{gr_m_2000} + Att_{gr_r_2000} = -0.9 \cdot \text{dB}$

at 4000 Hz $Att_{gr_4000} := Att_{gr_s_4000} + Att_{gr_m_4000} + Att_{gr_r_4000} = -0.9 \cdot \text{dB}$

at 8000 Hz $Att_{gr_8000} := Att_{gr_s_8000} + Att_{gr_m_8000} + Att_{gr_r_8000} = -0.9 \cdot \text{dB}$

Total attenuation for each frequency

at 63 Hz $Att_{63} := Att_{div} + Att_{atm_63} + Att_{gr_63} = 63.375 \cdot \text{dB}$

at 125 Hz $Att_{125} := Att_{div} + Att_{atm_125} + Att_{gr_125} = 68.077 \cdot \text{dB}$

at 250 Hz $Att_{250} := Att_{div} + Att_{atm_250} + Att_{gr_250} = 66.973 \cdot \text{dB}$

at 500 Hz $Att_{500} := Att_{div} + Att_{atm_500} + Att_{gr_500} = 66.526 \cdot \text{dB}$

at 1000 Hz $Att_{1000} := Att_{div} + Att_{atm_1000} + Att_{gr_1000} = 67.575 \cdot \text{dB}$

at 2000 Hz $Att_{2000} := Att_{div} + Att_{atm_2000} + Att_{gr_2000} = 71.074 \cdot \text{dB}$

at 4000 Hz $Att_{4000} := Att_{div} + Att_{atm_4000} + Att_{gr_4000} = 84.546 \cdot \text{dB}$

at 8000 Hz $Att_{8000} := Att_{div} + Att_{atm_8000} + Att_{gr_8000} = 133.654 \cdot \text{dB}$

Sound pressure levels at the POR

- at 63 Hz $L_{p_63} := L_{w_63} - Att_{63} = 28.1 \cdot \text{dBA}$
- at 125 Hz $L_{p_125} := L_{w_125} - Att_{125} = 25.6 \cdot \text{dBA}$
- at 250 Hz $L_{p_250} := L_{w_250} - Att_{250} = 28.2 \cdot \text{dBA}$
- at 500 Hz $L_{p_500} := L_{w_500} - Att_{500} = 29.7 \cdot \text{dBA}$
- at 1000 Hz $L_{p_1000} := L_{w_1000} - Att_{1000} = 29.8 \cdot \text{dBA}$
- at 2000 Hz $L_{p_2000} := L_{w_2000} - Att_{2000} = 25.8 \cdot \text{dBA}$
- at 4000 Hz $L_{p_4000} := L_{w_4000} - Att_{4000} = 10.5 \cdot \text{dBA}$
- at 8000 Hz $L_{p_8000} := L_{w_8000} - Att_{8000} = -49.1 \cdot \text{dBA}$

$$\text{Total_L}_p := 10 \cdot \log \left(10^{\frac{L_{p_63}}{10}} + 10^{\frac{L_{p_125}}{10}} + 10^{\frac{L_{p_250}}{10}} + 10^{\frac{L_{p_500}}{10}} + 10^{\frac{L_{p_1000}}{10}} + 10^{\frac{L_{p_2000}}{10}} + 10^{\frac{L_{p_4000}}{10}} + 10^{\frac{L_{p_8000}}{10}} \dots \right)$$

Total_L_p = 36.0·dBA

Impact of S11 on R080 POR as calculated by CADNA-A

Frequency [Hz]	31.5	63	125	250	500	1000	2000	4000	8000	Total
Sound pressure [dBA]		28.1	25.6	28.2	29.7	29.9	25.8	10.5	-49.0	36.0

Conclusion

Based on the calculation procedure provided in ISO 9613-2 and the parameters suggested by the Ministry of Environment in the Noise Guidelines for Wind Farms, Section 6.4.10 (October 2008), the estimated sound pressure level at the point of reception R080 produced by the noise source (wind turbine generator) S11 is 36.0 dBA, which is equal to the prediction of CADNA-A for the same POR (36.0 dBA).

It is important to note that POR R080 receives sound contributions from several sources, and the level shown above (36.0 dBA) corresponds only to the contribution from S11. The total sound pressure level at this POR was estimated by CADNA-A at 38.4 dBA.

Both the air and ground attenuation components were included and calculated based on ISO 9613-2 assuming 10°C ambient temperature and 70% relative humidity.

Configuration	
Parameter	Value
General	
Country	(user defined)
Max. Error (dB)	0.00
Max. Search Radius (m)	5000.00
Min. Dist Src to Rcvr	0.00
Partition	
Raster Factor	0.50
Max. Length of Section (m)	1000.00
Min. Length of Section (m)	1.00
Min. Length of Section (%)	0.00
Proj. Line Sources	On
Proj. Area Sources	On
Ref. Time	
Reference Time Day (min)	960.00
Reference Time Night (min)	480.00
Daytime Penalty (dB)	0.00
Recr. Time Penalty (dB)	0.00
Night-time Penalty (dB)	0.00
DTM	
Standard Height (m)	0.00
Model of Terrain	Triangulation
Reflection	
max. Order of Reflection	1
Search Radius Src	100.00
Search Radius Rcvr	100.00
Max. Distance Source - Rcvr	1000.00 1000.00
Min. Distance Rcvr - Reflector	1.00 1.00
Min. Distance Source - Reflector	0.10
Industrial (ISO 9613)	
Lateral Diffraction	some Obj
Obst. within Area Src do not shield	On
Screening	
	Excl. Ground Att. over Barrier
	Dz with limit (20/25)
Barrier Coefficients C1,2,3	3.0 20.0 0.0
Temperature (°C)	10
rel. Humidity (%)	70
Ground Absorption G	0.70
Wind Speed for Dir. (m/s)	3.0
Roads (RLS-90)	
Strictly acc. to RLS-90	
Railways (Schall 03)	
Strictly acc. to Schall 03 / Schall-Transrapid	
Aircraft (???)	
Strictly acc. to AzB	

Receiver
Name: Existing
ID: R080
X: 362200.34
Y: 4887074.70
Z: 84.50

Point Source, ISO 9613, Name: "Substation", ID: "Subs"

Nr.	X (m)	Y (m)	Z (m)	Refl.	Freq. (Hz)	LxT dB(A)	LxN dB(A)	K0 (dB)	Dc (dB)	Adiv (dB)	Aatm (dB)	Agr (dB)	Afol (dB)	Ahous (dB)	Abar (dB)	Cmet (dB)	RL (dB)	LrT dB(A)	LrN dB(A)
1	363269.13	4891095.48	94.00	0	32	60.6	60.6	0.0	0.0	83.4	0.1	-5.8	0.0	0.0	4.8	0.0	-0.0	-21.9	-21.9
2	363269.13	4891095.48	94.00	0	63	77.8	77.8	0.0	0.0	83.4	0.5	-5.8	0.0	0.0	4.8	0.0	-0.0	-5.0	-5.0
3	363269.13	4891095.48	94.00	0	125	90.9	90.9	0.0	0.0	83.4	1.7	3.8	0.0	0.0	1.0	0.0	-0.0	1.0	1.0
4	363269.13	4891095.48	94.00	0	250	96.4	96.4	0.0	0.0	83.4	4.3	0.7	0.0	0.0	4.1	0.0	-0.0	3.9	3.9
5	363269.13	4891095.48	94.00	0	500	101.8	101.8	0.0	0.0	83.4	8.0	-1.7	0.0	0.0	4.8	0.0	-0.0	7.3	7.3
6	363269.13	4891095.48	94.00	0	1000	99.0	99.0	0.0	0.0	83.4	15.2	-1.7	0.0	0.0	4.9	0.0	-0.0	-2.7	-2.7
7	363269.13	4891095.48	94.00	0	2000	95.2	95.2	0.0	0.0	83.4	40.2	-1.7	0.0	0.0	5.0	0.0	-0.0	-31.7	-31.7
8	363269.13	4891095.48	94.00	0	4000	90.0	90.0	0.0	0.0	83.4	136.3	-1.7	0.0	0.0	5.2	0.0	-0.0	-133.2	-133.2
9	363269.13	4891095.48	94.00	0	8000	79.9	79.9	0.0	0.0	83.4	486.3	-1.7	0.0	0.0	5.6	0.0	-0.0	-493.7	-493.7

Point Source, ISO 9613, Name: "(untitled)", ID: "S01"

Nr.	X (m)	Y (m)	Z (m)	Refl.	Freq. (Hz)	LxT dB(A)	LxN dB(A)	K0 (dB)	Dc (dB)	Adiv (dB)	Aatm (dB)	Agr (dB)	Afol (dB)	Ahous (dB)	Abar (dB)	Cmet (dB)	RL (dB)	LrT dB(A)	LrN dB(A)
1	359172.10	4889551.06	184.50	0	63	91.5	91.5	0.0	0.0	82.8	0.5	-3.6	0.0	0.0	0.0	0.0	-0.0	11.8	11.8
2	359172.10	4889551.06	184.50	0	125	93.7	93.7	0.0	0.0	82.8	1.6	1.6	0.0	0.0	0.0	0.0	-0.0	7.6	7.6
3	359172.10	4889551.06	184.50	0	250	95.2	95.2	0.0	0.0	82.8	4.1	-0.1	0.0	0.0	0.0	0.0	-0.0	8.4	8.4
4	359172.10	4889551.06	184.50	0	500	96.2	96.2	0.0	0.0	82.8	7.5	-1.1	0.0	0.0	0.0	0.0	-0.0	6.9	6.9
5	359172.10	4889551.06	184.50	0	1000	97.4	97.4	0.0	0.0	82.8	14.3	-1.1	0.0	0.0	0.0	0.0	-0.0	1.3	1.3
6	359172.10	4889551.06	184.50	0	2000	96.9	96.9	0.0	0.0	82.8	37.8	-1.1	0.0	0.0	0.0	0.0	-0.0	-22.7	-22.7
7	359172.10	4889551.06	184.50	0	4000	95.0	95.0	0.0	0.0	82.8	128.2	-1.1	0.0	0.0	0.0	0.0	-0.0	-115.0	-115.0
8	359172.10	4889551.06	184.50	0	8000	84.6	84.6	0.0	0.0	82.8	457.4	-1.1	0.0	0.0	0.0	0.0	-0.0	-454.5	-454.5

Point Source, ISO 9613, Name: "(untitled)", ID: "S03"

Nr.	X (m)	Y (m)	Z (m)	Refl.	Freq. (Hz)	LxT dB(A)	LxN dB(A)	K0 (dB)	Dc (dB)	Adiv (dB)	Aatm (dB)	Agr (dB)	Afol (dB)	Ahous (dB)	Abar (dB)	Cmet (dB)	RL (dB)	LrT dB(A)	LrN dB(A)
1	361257.04	4887433.92	183.20	0	63	91.2	91.2	0.0	0.0	71.1	0.1	-3.0	0.0	0.0	0.0	0.0	-0.0	22.9	22.9
2	361257.04	4887433.92	183.20	0	125	93.7	93.7	0.0	0.0	71.1	0.4	1.8	0.0	0.0	0.0	0.0	-0.0	20.4	20.4
3	361257.04	4887433.92	183.20	0	250	96.1	96.1	0.0	0.0	71.1	1.1	0.1	0.0	0.0	0.0	0.0	-0.0	23.9	23.9
4	361257.04	4887433.92	183.20	0	500	97.3	97.3	0.0	0.0	71.1	2.0	-0.9	0.0	0.0	0.0	0.0	-0.0	25.1	25.1
5	361257.04	4887433.92	183.20	0	1000	98.9	98.9	0.0	0.0	71.1	3.7	-0.9	0.0	0.0	0.0	0.0	-0.0	25.0	25.0
6	361257.04	4887433.92	183.20	0	2000	98.5	98.5	0.0	0.0	71.1	9.8	-0.9	0.0	0.0	0.0	0.0	-0.0	18.5	18.5
7	361257.04	4887433.92	183.20	0	4000	95.8	95.8	0.0	0.0	71.1	33.2	-0.9	0.0	0.0	0.0	0.0	-0.0	-7.7	-7.7
8	361257.04	4887433.92	183.20	0	8000	82.0	82.0	0.0	0.0	71.1	118.5	-0.9	0.0	0.0	0.0	0.0	-0.0	-106.8	-106.8

Point Source, ISO 9613, Name: "(untitled)", ID: "S04"

Nr.	X (m)	Y (m)	Z (m)	Refl.	Freq. (Hz)	LxT dB(A)	LxN dB(A)	K0 (dB)	Dc (dB)	Adiv (dB)	Aatm (dB)	Agr (dB)	Afol (dB)	Ahous (dB)	Abar (dB)	Cmet (dB)	RL (dB)	LrT dB(A)	LrN dB(A)
1	360408.29	4890076.32	184.50	0	63	91.2	91.2	0.0	0.0	81.9	0.4	-3.3	0.0	0.0	0.0	0.0	-0.0	12.2	12.2
2	360408.29	4890076.32	184.50	0	125	93.7	93.7	0.0	0.0	81.9	1.4	1.7	0.0	0.0	0.0	0.0	-0.0	8.7	8.7
3	360408.29	4890076.32	184.50	0	250	96.1	96.1	0.0	0.0	81.9	3.6	-0.0	0.0	0.0	0.0	0.0	-0.0	10.6	10.6
4	360408.29	4890076.32	184.50	0	500	97.3	97.3	0.0	0.0	81.9	6.7	-1.0	0.0	0.0	0.0	0.0	-0.0	9.7	9.7
5	360408.29	4890076.32	184.50	0	1000	98.9	98.9	0.0	0.0	81.9	12.8	-1.0	0.0	0.0	0.0	0.0	-0.0	5.2	5.2
6	360408.29	4890076.32	184.50	0	2000	98.5	98.5	0.0	0.0	81.9	33.8	-1.0	0.0	0.0	0.0	0.0	-0.0	-16.2	-16.2
7	360408.29	4890076.32	184.50	0	4000	95.8	95.8	0.0	0.0	81.9	114.6	-1.0	0.0	0.0	0.0	0.0	-0.0	-99.7	-99.7
8	360408.29	4890076.32	184.50	0	8000	82.0	82.0	0.0	0.0	81.9	408.8	-1.0	0.0	0.0	0.0	0.0	-0.0	-407.7	-407.7

Point Source, ISO 9613, Name: "(untitled)", ID: "S05"

Nr.	X (m)	Y (m)	Z (m)	Refl.	Freq. (Hz)	LxT dB(A)	LxN dB(A)	K0 (dB)	Dc (dB)	Adiv (dB)	Aatm (dB)	Agr (dB)	Afol (dB)	Ahous (dB)	Abar (dB)	Cmet (dB)	RL (dB)	LrT dB(A)	LrN dB(A)
1	362668.00	4888881.21	179.50	0	63	91.2	91.2	0.0	0.0	76.4	0.2	-3.0	0.0	0.0	0.0	0.0	-0.0	17.5	17.5
2	362668.00	4888881.21	179.50	0	125	93.7	93.7	0.0	0.0	76.4	0.8	1.8	0.0	0.0	0.0	0.0	-0.0	14.7	14.7
3	362668.00	4888881.21	179.50	0	250	96.1	96.1	0.0	0.0	76.4	2.0	0.1	0.0	0.0	0.0	0.0	-0.0	17.7	17.7
4	362668.00	4888881.21	179.50	0	500	97.3	97.3	0.0	0.0	76.4	3.6	-0.9	0.0	0.0	0.0	0.0	-0.0	18.2	18.2

Point Source, ISO 9613, Name: "(untitled)", ID: "S05"																			
Nr.	X	Y	Z	Refl.	Freq.	LxT	LxN	K0	Dc	Adiv	Aatm	Agr	Afol	Ahous	Abar	Cmet	RL	LrT	LrN
	(m)	(m)	(m)		(Hz)	dB(A)	dB(A)	(dB)	(dB)	(dB)	(dB)	(dB)	(dB)	(dB)	(dB)	(dB)	(dB)	dB(A)	dB(A)
5	362668.00	4888881.21	179.50	0	1000	98.9	98.9	0.0	0.0	76.4	6.8	-0.9	0.0	0.0	0.0	0.0	-0.0	16.5	16.5
6	362668.00	4888881.21	179.50	0	2000	98.5	98.5	0.0	0.0	76.4	18.1	-0.9	0.0	0.0	0.0	0.0	-0.0	4.9	4.9
7	362668.00	4888881.21	179.50	0	4000	95.8	95.8	0.0	0.0	76.4	61.2	-0.9	0.0	0.0	0.0	0.0	-0.0	-41.0	-41.0
8	362668.00	4888881.21	179.50	0	8000	82.0	82.0	0.0	0.0	76.4	218.4	-0.9	0.0	0.0	0.0	0.0	-0.0	-211.9	-211.9

Point Source, ISO 9613, Name: "(untitled)", ID: "S09"																			
Nr.	X	Y	Z	Refl.	Freq.	LxT	LxN	K0	Dc	Adiv	Aatm	Agr	Afol	Ahous	Abar	Cmet	RL	LrT	LrN
	(m)	(m)	(m)		(Hz)	dB(A)	dB(A)	(dB)	(dB)	(dB)	(dB)	(dB)	(dB)	(dB)	(dB)	(dB)	(dB)	dB(A)	dB(A)
1	360950.66	4887103.68	179.50	0	63	91.5	91.5	0.0	0.0	73.0	0.2	-3.0	0.0	0.0	0.0	0.0	-0.0	21.4	21.4
2	360950.66	4887103.68	179.50	0	125	93.7	93.7	0.0	0.0	73.0	0.5	1.8	0.0	0.0	0.0	0.0	-0.0	18.4	18.4
3	360950.66	4887103.68	179.50	0	250	95.2	95.2	0.0	0.0	73.0	1.3	0.1	0.0	0.0	0.0	0.0	-0.0	20.9	20.9
4	360950.66	4887103.68	179.50	0	500	96.2	96.2	0.0	0.0	73.0	2.4	-0.9	0.0	0.0	0.0	0.0	-0.0	21.7	21.7
5	360950.66	4887103.68	179.50	0	1000	97.4	97.4	0.0	0.0	73.0	4.6	-0.9	0.0	0.0	0.0	0.0	-0.0	20.8	20.8
6	360950.66	4887103.68	179.50	0	2000	96.9	96.9	0.0	0.0	73.0	12.1	-0.9	0.0	0.0	0.0	0.0	-0.0	12.7	12.7
7	360950.66	4887103.68	179.50	0	4000	95.0	95.0	0.0	0.0	73.0	41.1	-0.9	0.0	0.0	0.0	0.0	-0.0	-18.1	-18.1
8	360950.66	4887103.68	179.50	0	8000	84.6	84.6	0.0	0.0	73.0	146.5	-0.9	0.0	0.0	0.0	0.0	-0.0	-134.0	-134.0

Point Source, ISO 9613, Name: "(untitled)", ID: "S11"																			
Nr.	X	Y	Z	Refl.	Freq.	LxT	LxN	K0	Dc	Adiv	Aatm	Agr	Afol	Ahous	Abar	Cmet	RL	LrT	LrN
	(m)	(m)	(m)		(Hz)	dB(A)	dB(A)	(dB)	(dB)	(dB)	(dB)	(dB)	(dB)	(dB)	(dB)	(dB)	(dB)	dB(A)	dB(A)
1	361640.50	4887205.50	182.57	0	63	91.5	91.5	0.0	0.0	66.3	0.1	-3.0	0.0	0.0	0.0	0.0	-0.0	28.1	28.1
2	361640.50	4887205.50	182.57	0	125	93.7	93.7	0.0	0.0	66.3	0.2	1.5	0.0	0.0	0.0	0.0	-0.0	25.6	25.6
3	361640.50	4887205.50	182.57	0	250	95.2	95.2	0.0	0.0	66.3	0.6	0.1	0.0	0.0	0.0	0.0	-0.0	28.2	28.2
4	361640.50	4887205.50	182.57	0	500	96.2	96.2	0.0	0.0	66.3	1.1	-0.9	0.0	0.0	0.0	0.0	-0.0	29.7	29.7
5	361640.50	4887205.50	182.57	0	1000	97.4	97.4	0.0	0.0	66.3	2.1	-0.9	0.0	0.0	0.0	0.0	-0.0	29.9	29.9
6	361640.50	4887205.50	182.57	0	2000	96.9	96.9	0.0	0.0	66.3	5.6	-0.9	0.0	0.0	0.0	0.0	-0.0	25.9	25.9
7	361640.50	4887205.50	182.57	0	4000	95.0	95.0	0.0	0.0	66.3	19.1	-0.9	0.0	0.0	0.0	0.0	-0.0	10.5	10.5
8	361640.50	4887205.50	182.57	0	8000	84.6	84.6	0.0	0.0	66.3	68.2	-0.9	0.0	0.0	0.0	0.0	-0.0	-49.0	-49.0

Point Source, ISO 9613, Name: "(untitled)", ID: "S16"																			
Nr.	X	Y	Z	Refl.	Freq.	LxT	LxN	K0	Dc	Adiv	Aatm	Agr	Afol	Ahous	Abar	Cmet	RL	LrT	LrN
	(m)	(m)	(m)		(Hz)	dB(A)	dB(A)	(dB)	(dB)	(dB)	(dB)	(dB)	(dB)	(dB)	(dB)	(dB)	(dB)	dB(A)	dB(A)
1	361904.00	4889060.00	181.21	0	63	91.2	91.2	0.0	0.0	77.1	0.2	-3.0	0.0	0.0	0.0	0.0	-0.0	16.9	16.9
2	361904.00	4889060.00	181.21	0	125	93.7	93.7	0.0	0.0	77.1	0.8	1.8	0.0	0.0	0.0	0.0	-0.0	14.0	14.0
3	361904.00	4889060.00	181.21	0	250	96.1	96.1	0.0	0.0	77.1	2.1	0.1	0.0	0.0	0.0	0.0	-0.0	16.9	16.9
4	361904.00	4889060.00	181.21	0	500	97.3	97.3	0.0	0.0	77.1	3.9	-0.9	0.0	0.0	0.0	0.0	-0.0	17.3	17.3
5	361904.00	4889060.00	181.21	0	1000	98.9	98.9	0.0	0.0	77.1	7.3	-0.9	0.0	0.0	0.0	0.0	-0.0	15.4	15.4
6	361904.00	4889060.00	181.21	0	2000	98.5	98.5	0.0	0.0	77.1	19.4	-0.9	0.0	0.0	0.0	0.0	-0.0	2.9	2.9
7	361904.00	4889060.00	181.21	0	4000	95.8	95.8	0.0	0.0	77.1	65.9	-0.9	0.0	0.0	0.0	0.0	-0.0	-46.2	-46.2
8	361904.00	4889060.00	181.21	0	8000	82.0	82.0	0.0	0.0	77.1	234.9	-0.9	0.0	0.0	0.0	0.0	-0.0	-229.1	-229.1

Point Source, ISO 9613, Name: "(untitled)", ID: "S19"																			
Nr.	X	Y	Z	Refl.	Freq.	LxT	LxN	K0	Dc	Adiv	Aatm	Agr	Afol	Ahous	Abar	Cmet	RL	LrT	LrN
	(m)	(m)	(m)		(Hz)	dB(A)	dB(A)	(dB)	(dB)	(dB)	(dB)	(dB)	(dB)	(dB)	(dB)	(dB)	(dB)	dB(A)	dB(A)
1	365107.18	4889563.44	184.50	0	63	91.5	91.5	0.0	0.0	82.7	0.5	-3.5	0.0	0.0	0.0	0.0	-0.0	11.9	11.9
2	365107.18	4889563.44	184.50	0	125	93.7	93.7	0.0	0.0	82.7	1.6	1.6	0.0	0.0	0.0	0.0	-0.0	7.8	7.8
3	365107.18	4889563.44	184.50	0	250	95.2	95.2	0.0	0.0	82.7	4.0	-0.1	0.0	0.0	0.0	0.0	-0.0	8.6	8.6
4	365107.18	4889563.44	184.50	0	500	96.2	96.2	0.0	0.0	82.7	7.4	-1.1	0.0	0.0	0.0	0.0	-0.0	7.2	7.2
5	365107.18	4889563.44	184.50	0	1000	97.4	97.4	0.0	0.0	82.7	14.0	-1.1	0.0	0.0	0.0	0.0	-0.0	1.8	1.8
6	365107.18	4889563.44	184.50	0	2000	96.9	96.9	0.0	0.0	82.7	37.0	-1.1	0.0	0.0	0.0	0.0	-0.0	-21.7	-21.7
7	365107.18	4889563.44	184.50	0	4000	95.0	95.0	0.0	0.0	82.7	125.4	-1.1	0.0	0.0	0.0	0.0	-0.0	-112.0	-112.0
8	365107.18	4889563.44	184.50	0	8000	84.6	84.6	0.0	0.0	82.7	447.4	-1.1	0.0	0.0	0.0	0.0	-0.0	-444.4	-444.4

Point Source, ISO 9613, Name: "(untitled)", ID: "S20"																			
Nr.	X	Y	Z	Refl.	Freq.	LxT	LxN	K0	Dc	Adiv	Aatm	Agr	Afol	Ahous	Abar	Cmet	RL	LrT	LrN
	(m)	(m)	(m)		(Hz)	dB(A)	dB(A)	(dB)	(dB)	(dB)	(dB)	(dB)	(dB)	(dB)	(dB)	(dB)	(dB)	dB(A)	dB(A)
1	362894.06	4889249.14	183.86	0	63	91.2	91.2	0.0	0.0	78.2	0.3	-3.0	0.0	0.0	0.0	0.0	-0.0	15.8	15.8
2	362894.06	4889249.14	183.86	0	125	93.7	93.7	0.0	0.0	78.2	0.9	1.8	0.0	0.0	0.0	0.0	-0.0	12.8	12.8
3	362894.06	4889249.14	183.86	0	250	96.1	96.1	0.0	0.0	78.2	2.4	0.1	0.0	0.0	0.0	0.0	-0.0	15.5	15.5
4	362894.06	4889249.14	183.86	0	500	97.3	97.3	0.0	0.0	78.2	4.4	-0.9	0.0	0.0	0.0	0.0	-0.0	15.6	15.6
5	362894.06	4889249.14	183.86	0	1000	98.9	98.9	0.0	0.0	78.2	8.4	-0.9	0.0	0.0	0.0	0.0	-0.0	13.3	13.3
6	362894.06	4889249.14	183.86	0	2000	98.5	98.5	0.0	0.0	78.2	22.1	-0.9	0.0	0.0	0.0	0.0	-0.0	-0.9	-0.9
7	362894.06	4889249.14	183.86	0	4000	95.8	95.8	0.0	0.0	78.2	74.9	-0.9	0.0	0.0	0.0	0.0	-0.0	-56.3	-56.3
8	362894.06	4889249.14	183.86	0	8000	82.0	82.0	0.0	0.0	78.2	267.0	-0.9	0.0	0.0	0.0	0.0	-0.0	-262.3	-262.3

Point Source, ISO 9613, Name: "(untitled)", ID: "S21"																			
Nr.	X	Y	Z	Refl.	Freq.	LxT	LxN	K0	Dc	Adiv	Aatm	Agr	Afol	Ahous	Abar	Cmet	RL	LrT	LrN
	(m)	(m)	(m)		(Hz)	dB(A)	dB(A)	(dB)	(dB)	(dB)	(dB)	(dB)	(dB)	(dB)	(dB)	(dB)	(dB)	dB(A)	dB(A)
1	364880.81	4889038.86	180.18	0	63	91.5	91.5	0.0	0.0	81.4	0.4	-3.2	0.0	0.0	0.0	0.0	-0.0	12.8	12.8
2	364880.81	4889038.86	180.18	0	125	93.7	93.7	0.0	0.0	81.4	1.4	1.7	0.0	0.0	0.0	0.0	-0.0	9.2	9.2
3	364880.81	4889038.86	180.18	0	250	95.2	95.2	0.0	0.0	81.4	3.5	0.0	0.0	0.0	0.0	0.0	-0.0	10.3	10.3
4	364880.81	4889038.86	180.18	0	500	96.2	96.2	0.0	0.0	81.4	6.4	-1.0	0.0	0.0	0.0	0.0	-0.0	9.3	9.3
5	364880.81	4889038.86	180.18	0	1000	97.4	97.4	0.0	0.0	81.4	12.2	-1.0	0.0	0.0	0.0	0.0	-0.0	4.8	4.8
6	364880.81	4889038.86	180.18	0	2000	96.9	96.9	0.0	0.0	81.4	32.1	-1.0	0.0	0.0	0.0	0.0	-0.0	-15.7	-15.7
7	364880.81	4889038.86	180.18	0	4000	95.0	95.0	0.0	0.0	81.4	108.9	-1.0	0.0	0.0	0.0	0.0	-0.0	-94.4	-94.4
8	364880.81	4889038.86	180.18	0	8000	84.6	84.6	0.0	0.0	81.4	388.6	-1.0	0.0	0.0	0.0	0.0	-0.0	-384.4	-384.4

Point Source, ISO 9613, Name: "(untitled)", ID: "S22"																			
Nr.	X	Y	Z	Refl.	Freq.	LxT	LxN	K0	Dc	Adiv	Aatm	Agr	Afol	Ahous	Abar	Cmet	RL	LrT	LrN
	(m)	(m)	(m)		(Hz)	dB(A)	dB(A)	(dB)	(dB)	(dB)	(dB)	(dB)	(dB)	(dB)	(dB)	(dB)	(dB)	dB(A)	dB(A)
1	361447.08	4890656.10	189.50	0	63	91.2	91.2	0.0	0.0	82.3	0.5	-3.4	0.0	0.0	0.0	0.0	-0.0	11.9	11.9
2	361447.08	4890656.10	189.50	0	125	93.7	93.7	0.0	0.0	82.3	1.5	1.7	0.0	0.0	0.0	0.0	-0.0	8.3	8.3
3	361447.08	4890656.10	189.50	0	250	96.1	96.1	0.0	0.0	82.3	3.8	-0.1	0.0	0.0	0.0	0.0	-0.0	10.1	10.1
4	361447.08	4890656.10	189.50	0	500	97.3	97.3	0.0	0.0	82.3	7.1	-1.0	0.0	0.0	0.0	0.0	-0.0	9.0	9.0
5	361447.08	4890656.10	189.50	0	1000	98.9	98.9	0.0	0.0	82.3	13.4	-1.0	0.0	0.0	0.0	0.0	-0.0	4.3	4.3
6	361447.08	4890656.10	189.50	0	2000	98.5	98.5	0.0	0.0	82.3	35.4	-1.0	0.0	0.0	0.0	0.0	-0.0	-18.1	-18.1
7	361447.08	4890656.10	189.50	0	4000	95.8	95.8	0.0	0.0	82.3	120.0	-1.0	0.0	0.0	0.0	0.0	-0.0	-105.4	-105.4
8	361447.08	4890656.10	189.50	0	8000	82.0	82.0	0.0	0.0	82.3	427.9	-1.0	0.0	0.0	0.0	0.0	-0.0	-427.2	-427.2

Point Source, ISO 9613, Name: "(untitled)", ID: "S27"																			
Nr.	X	Y	Z	Refl.	Freq.	LxT	LxN	K0	Dc	Adiv	Aatm	Agr	Afol	Ahous	Abar	Cmet	RL	LrT	LrN
	(m)	(m)	(m)		(Hz)	dB(A)	dB(A)	(dB)	(dB)	(dB)	(dB)	(dB)	(dB)	(dB)	(dB)	(dB)	(dB)	dB(A)	dB(A)
1	365916.00	4890146.00	185.29	0	63	91.2	91.2	0.0	0.0	84.7	0.6	-4.1	0.0	0.0	0.0	0.0	-0.0	10.0	10.0
2	365916.00	4890146.00	185.29	0	125	93.7	93.7	0.0	0.0	84.7	2.0	1.5	0.0	0.0	0.0	0.0	-0.0	5.6	5.6
3	365916.00	4890146.00	185.29	0	250	96.1	96.1	0.0	0.0	84.7	5.0	-0.2	0.0	0.0	0.0	0.0	-0.0	6.6	6.6
4	365916.00	4890146.00	185.29	0	500	97.3	97.3	0.0	0.0	84.7	9.3	-1.2	0.0	0.0	0.0	0.0	-0.0	4.6	4.6
5	365916.00	4890146.00	185.29	0	1000	98.9	98.9	0.0	0.0	84.7	17.6	-1.2	0.0	0.0	0.0	0.0	-0.0	-2.2	-2.2
6	365916.00	4890146.00	185.29	0	2000	98.5	98.5	0.0	0.0	84.7	46.6	-1.2	0.0	0.0	0.0	0.0	-0.0	-31.5	-31.5
7	365916.00	4890146.00	185.29	0	4000	95.8	95.8	0.0	0.0	84.7	158.0	-1.2	0.0	0.0	0.0	0.0	-0.0	-145.7	-145.7
8	365916.00	4890146.00	185.29	0	8000	82.0	82.0	0.0	0.0	84.7	563.6	-1.2	0.0	0.0	0.0	0.0	-0.0	-565.0	-565.0

Point Source, ISO 9613, Name: "(untitled)", ID: "S29"																			
Nr.	X	Y	Z	Refl.	Freq.	LxT	LxN	K0	Dc	Adiv	Aatm	Agr	Afol	Ahous	Abar	Cmet	RL	LrT	LrN
	(m)	(m)	(m)		(Hz)	dB(A)	dB(A)	(dB)	(dB)	(dB)	(dB)	(dB)	(dB)	(dB)	(dB)	(dB)	(dB)	dB(A)	dB(A)
1	359561.75	4889909.18	182.65	0	63	91.5	91.5	0.0	0.0	82.8	0.5	-3.6	0.0	0.0	0.0	0.0	-0.0	11.9	11.9
2	359561.75	4889909.18	182.65	0	125	93.7	93.7	0.0	0.0	82.8	1.6	1.6	0.0	0.0	0.0	0.0	-0.0	7.7	7.7
3	359561.75	4889909.18	182.65	0	250	95.2	95.2	0.0	0.0	82.8	4.0	-0.1	0.0	0.0	0.0	0.0	-0.0	8.5	8.5
4	359561.75	4889909.18	182.65	0	500	96.2	96.2	0.0	0.0	82.8	7.5	-1.1	0.0	0.0	0.0	0.0	-0.0	7.0	7.0
5	359561.75	4889909.18	182.65	0	1000	97.4	97.4	0.0	0.0	82.8	14.2	-1.1	0.0	0.0	0.0	0.0	-0.0	1.5	1.5
6	359561.75	4889909.18	182.65	0	2000	96.9	96.9	0.0	0.0	82.8	37.4	-1.1	0.0	0.0	0.0	0.0	-0.0	-22.2	-22.2
7	359561.75	4889909.18	182.65	0	4000	95.0	95.0	0.0	0.0	82.8	126.9	-1.1	0.0	0.0	0.0	0.0	-0.0	-113.6	-113.6
8	359561.75	4889909.18	182.65	0	8000	84.6	84.6	0.0	0.0	82.8	452.8	-1.1	0.0	0.0	0.0	0.0	-0.0	-449.9	-449.9

Point Source, ISO 9613, Name: "(untitled)", ID: "S31"																			
Nr.	X	Y	Z	Refl.	Freq.	LxT	LxN	K0	Dc	Adiv	Aatm	Agr	Afol	Ahous	Abar	Cmet	RL	LrT	LrN
	(m)	(m)	(m)		(Hz)	dB(A)	dB(A)	(dB)	(dB)	(dB)	(dB)	(dB)	(dB)	(dB)	(dB)	(dB)	(dB)	dB(A)	dB(A)
1	362343.14	4891028.43	189.50	0	63	91.5	91.5	0.0	0.0	83.0	0.5	-3.6	0.0	0.0	0.0	0.0	-0.0	11.7	11.7
2	362343.14	4891028.43	189.50	0	125	93.7	93.7	0.0	0.0	83.0	1.6	1.6	0.0	0.0	0.0	0.0	-0.0	7.5	7.5
3	362343.14	4891028.43	189.50	0	250	95.2	95.2	0.0	0.0	83.0	4.1	-0.1	0.0	0.0	0.0	0.0	-0.0	8.2	8.2
4	362343.14	4891028.43	189.50	0	500	96.2	96.2	0.0	0.0	83.0	7.6	-1.1	0.0	0.0	0.0	0.0	-0.0	6.7	6.7
5	362343.14	4891028.43	189.50	0	1000	97.4	97.4	0.0	0.0	83.0	14.5	-1.1	0.0	0.0	0.0	0.0	-0.0	1.1	1.1
6	362343.14	4891028.43	189.50	0	2000	96.9	96.9	0.0	0.0	83.0	38.3	-1.1	0.0	0.0	0.0	0.0	-0.0	-23.2	-23.2
7	362343.14	4891028.43	189.50	0	4000	95.0	95.0	0.0	0.0	83.0	129.7	-1.1	0.0	0.0	0.0	0.0	-0.0	-116.6	-116.6
8	362343.14	4891028.43	189.50	0	8000	84.6	84.6	0.0	0.0	83.0	462.6	-1.1	0.0	0.0	0.0	0.0	-0.0	-459.8	-459.8

Point Source, ISO 9613, Name: "(untitled)", ID: "S34"																			
Nr.	X	Y	Z	Refl.	Freq.	LxT	LxN	K0	Dc	Adiv	Aatm	Agr	Afol	Ahous	Abar	Cmet	RL	LrT	LrN
	(m)	(m)	(m)		(Hz)	dB(A)	dB(A)	(dB)	(dB)	(dB)	(dB)	(dB)	(dB)	(dB)	(dB)	(dB)	(dB)	dB(A)	dB(A)
1	363323.99	4889900.50	179.50	0	63	91.5	91.5	0.0	0.0	80.7	0.4	-3.0	0.0	0.0	0.0	0.0	-0.0	13.5	13.5
2	363323.99	4889900.50	179.50	0	125	93.7	93.7	0.0	0.0	80.7	1.3	1.8	0.0	0.0	0.0	0.0	-0.0	10.0	10.0
3	363323.99	4889900.50	179.50	0	250	95.2	95.2	0.0	0.0	80.7	3.2	0.1	0.0	0.0	0.0	0.0	-0.0	11.3	11.3
4	363323.99	4889900.50	179.50	0	500	96.2	96.2	0.0	0.0	80.7	5.9	-0.9	0.0	0.0	0.0	0.0	-0.0	10.6	10.6

Point Source, ISO 9613, Name: "(untitled)", ID: "S34"																			
Nr.	X	Y	Z	Refl.	Freq.	LxT	LxN	K0	Dc	Adiv	Aatm	Agr	Afol	Ahous	Abar	Cmet	RL	LrT	LrN
	(m)	(m)	(m)		(Hz)	dB(A)	dB(A)	(dB)	(dB)	(dB)	(dB)	(dB)	(dB)	(dB)	(dB)	(dB)	(dB)	dB(A)	dB(A)
5	363323.99	4889900.50	179.50	0	1000	97.4	97.4	0.0	0.0	80.7	11.1	-0.9	0.0	0.0	0.0	0.0	-0.0	6.5	6.5
6	363323.99	4889900.50	179.50	0	2000	96.9	96.9	0.0	0.0	80.7	29.4	-0.9	0.0	0.0	0.0	0.0	-0.0	-12.3	-12.3
7	363323.99	4889900.50	179.50	0	4000	95.0	95.0	0.0	0.0	80.7	99.7	-0.9	0.0	0.0	0.0	0.0	-0.0	-84.5	-84.5
8	363323.99	4889900.50	179.50	0	8000	84.6	84.6	0.0	0.0	80.7	355.6	-0.9	0.0	0.0	0.0	0.0	-0.0	-350.8	-350.8

Point Source, ISO 9613, Name: "(untitled)", ID: "S36"																			
Nr.	X	Y	Z	Refl.	Freq.	LxT	LxN	K0	Dc	Adiv	Aatm	Agr	Afol	Ahous	Abar	Cmet	RL	LrT	LrN
	(m)	(m)	(m)		(Hz)	dB(A)	dB(A)	(dB)	(dB)	(dB)	(dB)	(dB)	(dB)	(dB)	(dB)	(dB)	(dB)	dB(A)	dB(A)
1	364588.58	4888397.36	178.68	0	63	91.2	91.2	0.0	0.0	79.7	0.3	-3.0	0.0	0.0	0.0	0.0	-0.0	14.1	14.1
2	364588.58	4888397.36	178.68	0	125	93.7	93.7	0.0	0.0	79.7	1.1	1.8	0.0	0.0	0.0	0.0	-0.0	11.1	11.1
3	364588.58	4888397.36	178.68	0	250	96.1	96.1	0.0	0.0	79.7	2.8	0.1	0.0	0.0	0.0	0.0	-0.0	13.5	13.5
4	364588.58	4888397.36	178.68	0	500	97.3	97.3	0.0	0.0	79.7	5.3	-0.9	0.0	0.0	0.0	0.0	-0.0	13.2	13.2
5	364588.58	4888397.36	178.68	0	1000	98.9	98.9	0.0	0.0	79.7	10.0	-0.9	0.0	0.0	0.0	0.0	-0.0	10.1	10.1
6	364588.58	4888397.36	178.68	0	2000	98.5	98.5	0.0	0.0	79.7	26.4	-0.9	0.0	0.0	0.0	0.0	-0.0	-6.7	-6.7
7	364588.58	4888397.36	178.68	0	4000	95.8	95.8	0.0	0.0	79.7	89.5	-0.9	0.0	0.0	0.0	0.0	-0.0	-72.5	-72.5
8	364588.58	4888397.36	178.68	0	8000	82.0	82.0	0.0	0.0	79.7	319.3	-0.9	0.0	0.0	0.0	0.0	-0.0	-316.1	-316.1

Point Source, ISO 9613, Name: "(untitled)", ID: "S37"																			
Nr.	X	Y	Z	Refl.	Freq.	LxT	LxN	K0	Dc	Adiv	Aatm	Agr	Afol	Ahous	Abar	Cmet	RL	LrT	LrN
	(m)	(m)	(m)		(Hz)	dB(A)	dB(A)	(dB)	(dB)	(dB)	(dB)	(dB)	(dB)	(dB)	(dB)	(dB)	(dB)	dB(A)	dB(A)
1	365500.96	4889854.04	185.85	0	63	91.2	91.2	0.0	0.0	83.7	0.5	-3.8	0.0	0.0	0.0	0.0	-0.0	10.8	10.8
2	365500.96	4889854.04	185.85	0	125	93.7	93.7	0.0	0.0	83.7	1.8	1.5	0.0	0.0	0.0	0.0	-0.0	6.7	6.7
3	365500.96	4889854.04	185.85	0	250	96.1	96.1	0.0	0.0	83.7	4.5	-0.2	0.0	0.0	0.0	0.0	-0.0	8.1	8.1
4	365500.96	4889854.04	185.85	0	500	97.3	97.3	0.0	0.0	83.7	8.3	-1.2	0.0	0.0	0.0	0.0	-0.0	6.4	6.4
5	365500.96	4889854.04	185.85	0	1000	98.9	98.9	0.0	0.0	83.7	15.8	-1.2	0.0	0.0	0.0	0.0	-0.0	0.6	0.6
6	365500.96	4889854.04	185.85	0	2000	98.5	98.5	0.0	0.0	83.7	41.7	-1.2	0.0	0.0	0.0	0.0	-0.0	-25.8	-25.8
7	365500.96	4889854.04	185.85	0	4000	95.8	95.8	0.0	0.0	83.7	141.4	-1.2	0.0	0.0	0.0	0.0	-0.0	-128.2	-128.2
8	365500.96	4889854.04	185.85	0	8000	82.0	82.0	0.0	0.0	83.7	504.5	-1.2	0.0	0.0	0.0	0.0	-0.0	-505.0	-505.0

Suite 500, 4342 Queen Street
Niagara Falls, Ontario, Canada L2E 7J7
Tel 905 374 5200 ♦ Fax 905 374 1157



Suite 500, 4342 Queen Street
Niagara Falls, Ontario, Canada L2E 7J7
Tel 905 374 5200 ♦ Fax 905 374 1157