

**Amherst Island Wind Energy
Project,
Erosion and Sediment Control
and Stormwater Management
Plan Report, Phase 1**



Prepared for:
Windlectric Inc.
2845 Bristol Circle
Oakville, ON L6H 7H7

Prepared by:
Stantec Consulting Ltd.
100-300 Hagey Blvd
Waterloo, ON N2H 6M7

1609-60595

October 17, 2016

Sign-off Sheet

This document entitled Amherst Island Wind Energy Project, Erosion and Sediment Control and Stormwater Management Plan Report, Phase 1 was prepared by Stantec Consulting Ltd. ("Stantec") for the account of Windlectric Inc. (the "Client"). Any reliance on this document by any third party is strictly prohibited. The material in it reflects Stantec's professional judgment in light of the scope, schedule and other limitations stated in the document and in the contract between Stantec and the Client. The opinions in the document are based on conditions and information existing at the time the document was published and do not take into account any subsequent changes. In preparing the document, Stantec did not verify information supplied to it by others. Any use which a third party makes of this document is the responsibility of such third party. Such third party agrees that Stantec shall not be responsible for costs or damages of any kind, if any, suffered by it or any other third party as a result of decisions made or actions taken based on this document.



Prepared by _____
(signature)

Dave Williams, P.Eng.
Water Resources Engineer

Reviewed by _____
(signature)

Jayson Innes, P.Eng.
Water Resources Engineer

Table of Contents

1.0	INTRODUCTION	1.1
1.1	STUDY APPROACH	1.1
1.2	BACKGROUND INFORMATION	1.2
2.0	ASSESSMENT OF POTENTIAL HYDROLOGIC IMPACTS AND MITIGATION – OPERATIONAL PHASE (SWM).....	2.1
2.1	EXISTING CONDITIONS.....	2.1
2.2	PROPOSED CONDITIONS.....	2.2
2.3	ASSESSMENT OF HYDROLOGIC IMPACTS AND NEED FOR STORMWATER CONTROLS	2.3
3.0	ASSESSMENT OF POTENTIAL HYDROLOGIC IMPACTS AND MITIGATION – DURING-CONSTRUCTION PHASE (ESC).....	3.4
3.1	ASSESSMENT OF EROSION POTENTIAL.....	3.4
3.2	DURING CONSTRUCTION DEWATERING.....	3.4
3.3	EROSION AND SEDIMENTATION CONTROL PLAN.....	3.5
3.4	EROSION AND SEDIMENTATION CONTROL MONITORING PLAN.....	3.7
3.5	LONG TERM EROSION AND SEDIMENT CONTROL.....	3.8
4.0	CONCLUSIONS.....	4.1

LIST OF TABLES

Table 1: Existing Conditions Impervious Coverage.....	2.1
Table 2: Proposed Conditions Impervious Coverage.....	2.2

AMHERST ISLAND WIND ENERGY PROJECT, EROSION AND SEDIMENT CONTROL AND STORMWATER MANAGEMENT PLAN REPORT, PHASE 1

Introduction
October 17, 2016

1.0 INTRODUCTION

Stantec Consulting Ltd. (Stantec) was retained by Windlectric Inc. (the Proponent) to assess and review the need for erosion and sediment control (ESC) and stormwater management (SWM) measures associated with the proposed development of the Amherst Island Wind Energy Project (herein referred to as the "Project"). This report is intended to address the requirements for SWM measures as described in Section H of the project's REA Approval (#7123-9W9NH2) and supplement the information included as part of the application for a Renewable Energy Approval (the REA Application).

Phase 1 of the Project includes the installation of a dock, on Lake Ontario, to provide access to Amherst Island for construction vehicles. In addition, an island dock access road will provide access for construction vehicles to a laydown area for temporary aggregate stockpiling adjacent to the Island Dock access road. Also included in Phase 1 is the construction of an access road south of Front Road, providing access to the future central laydown area and Island Substation which will be part of the Phase 2 Stormwater Management and Erosion and Sediment Control Plan. Previous SWM documentation for the construction of the Island and Mainland docks and associated access roads (*Amherst Island Wind Energy Project, Stormwater Management Design Brief*, Stantec, 2015) was submitted to the MOECC and subsequently approved.

This ESC/SWM Report summarizes the assessment of potential hydrologic impacts associated with the construction phase (i.e., ESC) and operational phase (i.e., SWM) of the Project. Potential hydrologic impacts assessed include changes to the quality and/or quantity discharged to the surface or sub-surface receiving systems. The objective of the report is to demonstrate that the Project design and proposed mitigation measures associated with the construction and operation phases of the Project, as described in the REA Application, detailed engineering design, and herein, are sufficient to minimize any potential impacts to environmental features within the Project area and, further, to provide details on the mitigation measures and control measures that will be implemented.

1.1 STUDY APPROACH

The study approach involved the following components:

- A qualitative assessment of existing hydrologic conditions of the area and receiving systems.
- A review of the proposed Project activities as described in the REA Application with an emphasis on assessing potential for impacts associated with changes in hydrology.
- A semi-quantitative analysis of existing and proposed conditions to determine potential for short-term or long-term effects on receiving systems and mitigative approaches, if necessary.

AMHERST ISLAND WIND ENERGY PROJECT, EROSION AND SEDIMENT CONTROL AND STORMWATER MANAGEMENT PLAN REPORT, PHASE 1

Introduction
October 17, 2016

- Development of an erosion and sediment control (ESC) strategy outlining the anticipated approach to minimize of impacts related to construction.

1.2 BACKGROUND INFORMATION

A variety of sources have been referenced during the preparation of this ESC/SWM Report, including project-specific documentation, such as the various reports submitted in support of the REA application, and more general industry-standard design guidance documentation and/or literature references, as follows:

General Guidance Documentation / Literature

- *Low Impact Development Stormwater Management Planning and Design Guide*, Credit Valley Conservation and Toronto and Region Conservation, 2011
- *Erosion and Sediment Control Guideline for Urban Construction (ESC Guidelines)*, Greater Golden Horseshoe Conservation Authorities, Dec. 2006
- *Stormwater Management Planning and Design Manual (SWMPD Manual)*, Ontario Ministry of the Environment, March 2003
- *Guidelines for Evaluating Construction Activities on Water Resources*, Ontario Ministry of the Environment, January 1995

Discussions and conclusions reached herein related to the relevance/significance of impervious coverage and its relative impact on the hydrology of receiving systems are based upon widely available literature, readily obtained in any Internet search for related terms such as "impervious coverage and aquatic systems". Two excellent examples include:

- *Impacts of Impervious Cover on Aquatic System, Watershed Protection Research Monograph No. 1*, Schueler, T., Center for Watershed Protection, March 2003
- *The Importance of Imperviousness*, from *Watershed Protection Techniques*, Vol.1, No.3 – Fall 1994, Schueler, T., Centre for Watershed Protection, 1994

Project-Specific Consultation / Documentation

- *Hydrogeological Investigation – Proposed Amherst Island Wind Farm*, Stantec Consulting Ltd., January 2016
- *Amherst Island Wind Energy Project: Dock Construction Stormwater Management Brief*, Stantec Consulting Ltd., December 2015
- *Amherst Island Wind Energy Project: Culvert Sizing Design Brief*, Stantec Consulting Ltd., October 2015
- *Supplementary Geotechnical Investigation – Proposed Amherst Island Wind Farm*, Stantec Consulting Ltd., September 2015

**AMHERST ISLAND WIND ENERGY PROJECT,
EROSION AND SEDIMENT CONTROL AND STORMWATER MANAGEMENT PLAN REPORT, PHASE 1**

Introduction
October 17, 2016

- *Amherst Island Wind Energy Project: Invista Dock – Drainage Assessment*, Stantec Consulting Ltd., August 2015
- *Geophysical Investigation to Map bedrock in Amherst Island, Ontario*, Geophysics GPR International Inc., June 2015
- *Amherst Island Wind Energy Project: Water Assessment and Waterbody Report (WA/WR)*, Stantec Consulting Ltd., April 2013
- *Amherst Island Wind Energy Project: Design and Operations Report (DOR)*, Stantec Consulting Ltd., December 2013
- *Amherst Island Wind Energy Project: Construction Plan Report*, Stantec Consulting Ltd., December 2013

2.0 ASSESSMENT OF POTENTIAL HYDROLOGIC IMPACTS AND MITIGATION – OPERATIONAL PHASE (SWM)

2.1 EXISTING CONDITIONS

As illustrated in the attached Figure 1, and summarized in Table 1, the proposed Project is situated on predominantly agricultural lands with very low existing impervious coverage. Runoff drains overland to local drainage draws, small watercourses, and/or wetland features, ultimately discharging to Lake Ontario. Drainage patterns are to be maintained through the use of limited grading, maintenance of surrounding land uses (e.g., agricultural operations, and the provision of conveyance infrastructure (e.g., culverts). As such, impervious coverage represents the primary parameter of potential impact to the hydrology of the Project area.

Catchment areas were delineated so as to encompass all proposed infrastructure and, therefore, any hydrologic impacts associated with proposed impervious coverage increases, allowing for a comparison between existing and proposed conditions. Owing to the dispersed characteristic of the proposed wind farm, with infrastructure distributed at very low density across a large area, deriving a reasonable comparison point at which to compare pre- and post-development conditions is somewhat subjective. For the purposes of the analysis described herein, comparison points have been set at the closest downstream road crossing of a given catchment within which development (i.e., the creation of new impervious surfaces) is proposed. These locations have been selected since, should a hydrologic impact occur as a result of development, this is the location at which it would be most noticeable and of most concern to the public. A summary of catchment IDs and areas and existing conditions impervious coverage statistics is provided in Table 1.

Table 1: Existing Conditions Impervious Coverage

Receivers / Catchment	Drainage Area (ha)	Impervious Coverage	
		(ha)	(%)
4	80.92	0.37	0.46
5	7.15	0.04	0.56
15	89.97	0.87	0.97

**AMHERST ISLAND WIND ENERGY PROJECT,
EROSION AND SEDIMENT CONTROL AND STORMWATER MANAGEMENT PLAN REPORT, PHASE 1**

Assessment of Potential Hydrologic Impacts and Mitigation – Operational Phase (SWM)
October 17, 2016

2.2 PROPOSED CONDITIONS

Access Roads

As described in the *Construction Plan Report*, access roads will be approximately 6 m wide and will not require resizing for the operation phase, with the exception of the entrances off Township or County roads that require wider turning radii, of approximately 50 m, during construction. The access roads will be constructed of engineered compacted fill and/or soil stabilization material. The depth of the roadbed will be approximately 200 - 350 mm. Alternatively; soil stabilizer will be utilized with a reduced granular material depth. Typical construction details for the access road and temporary widenings can be found in Figure 1.

The construction of roads will include the excavation and removal of topsoil, placing of geotextile fabrics where necessary, placement of aggregate and gravel materials as a road base, and further grading and compaction as necessary. From a hydrologic impact perspective, the access roads are considered generally equivalent to a typical farm access (i.e., driveway). Photographs of a typical wind project access road construction have been appended for reference.

For the purposes of conservative analysis, all areas proposed for granular surface treatment (e.g., access roads) have been conservatively considered as 100% impervious within the current analysis. The drainage catchments previously delineated and described under the existing conditions analysis were subsequently analyzed for impervious coverage under proposed conditions, with the results as summarized in Table 2.

Table 2: Proposed Conditions Impervious Coverage

Receivers / Catchment	Drainage Area (ha)	Impervious Coverage	
		(ha)	(%)
4	80.92	0.96	1.19
5	7.15	0.19	2.66
15	89.97	2.81	3.12

Island Dock Temporary Laydown Area

The proposed 0.9 ha temporary laydown area (Drawing C-403, Attached) is located along the east side of the island dock access road connecting the future island dock and Front Road. Runoff from the northern 0.6 ha of the laydown area drains as overland flow towards Lake Ontario through a vegetated buffer immediately adjacent to the lake. The land to the south drains as overland sheet flow to a roadside ditch along Front Road, discharging to an unnamed tributary under a private laneway to Lake Ontario approximately 200 m east of the intersection of the proposed island dock access road and front road. Preparation of the laydown area

**AMHERST ISLAND WIND ENERGY PROJECT,
EROSION AND SEDIMENT CONTROL AND STORMWATER MANAGEMENT PLAN REPORT, PHASE 1**

Assessment of Potential Hydrologic Impacts and Mitigation – Operational Phase (SWM)
October 17, 2016

includes establishing all proposed erosion and sediment controls (Drawing C-401), excavation and removal of topsoil and proof-rolling the native subsoil prior to stockpile placement.

2.3 ASSESSMENT OF HYDROLOGIC IMPACTS AND NEED FOR STORMWATER CONTROLS

Industry-standard approaches to assessing the potential for hydrologic impacts related to changes in the amount of urban impervious coverage, as supported by literature (see references in Section 1.2), generally conclude that watersheds typically maintain pre-development hydrology characteristics until they exceed 10-15% impervious coverage.

As illustrated in the calculations above, the impervious coverage in the three (3) catchments identified as part of this study remains below 3.12%. It is concluded, therefore, that the development of the Project will have negligible impact on the hydrology of the area and receiving systems.

Regarding the potential for flow re-direction or obstruction, the REA documents include commitments to minimizing grading and the implementation of drainage infrastructure (e.g., culverts or overland flow routes) as necessary to maintain drainage patterns per existing conditions. Care will be taken where construction is proposed in areas of known tile drainage systems to minimize damage to these systems and to repair any inadvertent damage that may occur, maintaining existing conditions drainage characteristics. On-going landowner liaison will occur as any impacts may only become noticeable at a later date.

Given the general maintenance of at-surface drainage conditions (i.e., no substantive grading or re-direction of surface water away from existing features) and vegetative conditions across the majority of the site, and the minimal introduction of impervious coverage, a formal stormwater management system for access roads is not proposed.

Island Dock Temporary Laydown Area

Aggregate stockpiles will not be compacted allowing rainfall to migrate through the stockpile where it will have the opportunity to infiltrate into the native subsoils. Any incidental increase in runoff as a result of temporary aggregate stockpiling will be attenuated and filtered through downstream vegetated conveyance systems in addition to the robust sediment and erosion controls described in Section 3 of this report. A formal Stormwater management system for the island dock temporary laydown area is not proposed.

3.0 ASSESSMENT OF POTENTIAL HYDROLOGIC IMPACTS AND MITIGATION (ESC)

3.1 ASSESSMENT OF EROSION POTENTIAL

An assessment of the erosion potential of the construction area was completed following the methodology outlined in the *ESC Guidelines* (GGHACA, 2006). The erosion potential is based on an assessment of three primary factors, namely slope gradient, slope length and soil texture (erodibility), with the resultant designation of either “low”, “medium”, or “high” erosion potential. The relative level of erosion potential dictates, to some extent, the comprehensiveness of the resultant ESC system design, monitoring, and maintenance program.

Beyond the three-parameter approach described by the Guidelines, it is often also appropriate to account for the relative sensitivity of the receiving systems as it relates to potential sediment transport offsite during construction. While never leading to a *reduction* in assessed erosion potential, such an assessment could result in a conclusion that diligence in excess of that already assessed is warranted. In this particular case, the receiving system is Lake Ontario which, should a spill occur, presents cleanup challenges if any sediment is to migrate into the Lake. It would be incumbent upon the proponent and contractor to elevate the level of attention paid to protecting the Lake against construction related impacts.

The existing and proposed (post-construction) condition gradients on the Project site can be classified as moderate (2 – 10% - Overland flow paths) to steep (>10% - Access road embankments), with predominantly long slopes (greater than 30 m). Site soils are comprised primarily of sand and silt tills, which are considered to represent a high erodibility potential (Table A1, ESC Guidelines). Therefore, based on this classification, the site has a “high” erosion potential.

The setbacks provided between the proposed project infrastructure and the surface water receiving features and the existing agricultural land uses surrounding the proposed infrastructure and the features, are such that the derivation of an ESC strategy in accordance with the “high” erosion potential assessment should satisfactorily address the potential impacts to the water features.

3.2 DURING CONSTRUCTION DEWATERING

As per the Construction Plan Report, it is not expected that the water table will be intercepted by any construction activities, though it is possible. Should dewatering be required, such would affect the local near-surface water table only for the period for construction (until concrete is hardened). Post-construction, the water table would return to pre-construction levels and the relatively small ‘footprint’ of the road base would not affect flow volumes or patterns, or the deep groundwater regime. Pumping rates are not anticipated to exceed 50,000 litres per day.

**AMHERST ISLAND WIND ENERGY PROJECT,
EROSION AND SEDIMENT CONTROL AND STORMWATER MANAGEMENT PLAN REPORT, PHASE 1**

Assessment of Potential Hydrologic Impacts and Mitigation (ESC)
October 17, 2016

Although culvert installation works are proposed to be completed in the dry, culvert installation may require minor dewatering during construction. The construction of watercourse crossings are understood to require approximately 1-3 days per crossing including the installation of minor water diversion infrastructure (if necessary), site excavation/preparation, culvert installation, backfilling, and removal of diversion measures. It is anticipated that the headwater features will be crossed using standard passive diversion or “dam and pump” dry crossing techniques. Prior to commencing crossing construction, weather forecasts will be reviewed to assess the potential for significant precipitation. In-stream activities will be delayed if foul weather is forecast and/or flows are elevated beyond available pump capacity or 50,000 litres per day.

Any required dewatering operations will be completed such that discharge rates will not cause any flooding and erosion concerns for the downstream natural areas. In order to prevent sediment migration to the downstream areas dewatering discharges may be treated with a variety of measures including but not limited to filter socks, sediment traps, and “frog’s foot” dissipaters at the discretion of the contractor. Dewatering discharges will be directed through the sediment control measures to a gently sloped vegetated area greater than 30 m from any watercourse or wetland feature.

Detailed pumping records will be kept on site to ensure that maximum pumping rates are not exceeded.

3.3 EROSION AND SEDIMENTATION CONTROL PLAN

As described in the *Construction Plan Report*, the various construction activities required to develop the site include topsoil removal, minor grading activities, infrastructure installation, creation of granular access roads, and general construction traffic. If left unmitigated, these activities will result in impacts ranging from disturbance of at-surface soils and exposure of the native sub-soils to potential erosion and sediment transport to offsite locations.

Erosion control will be achieved primarily through the excavation-and-backfill methods of construction and by limiting the duration of exposure of disturbed sub-soils inherent in the construction process. For example, access road construction includes the removal of topsoil and sub-soils as necessary to achieve a competent base, followed by the placement of granular material back to existing grade elevations (or marginally above); hence, the work areas are generally “self-contained” and protected from erosion and sediment transport by definition. Further, at any given location, these works will be completed in short order (1-2 days expected), providing little opportunity for sub-soils to be disturbed and entrained in storm runoff.

**AMHERST ISLAND WIND ENERGY PROJECT,
EROSION AND SEDIMENT CONTROL AND STORMWATER MANAGEMENT PLAN REPORT, PHASE 1**

Assessment of Potential Hydrologic Impacts and Mitigation (ESC)
October 17, 2016

In addition to limiting the potential for erosion, sediment control measures will be implemented prior to any grading or servicing works commencing as shown on the accompanying Plans, and include, but not necessarily be limited to, the following items:

- Sediment and erosion control measures should be implemented prior to construction and maintained during the construction phase to prevent entry of sediment into the water:
 - Erect silt fence (per OPSD 219.110) on the downstream sides of disturbed areas within 30 m of the buffers to environmental features and around entirety of temporarily stockpiled soils;
 - Temporarily stockpiled materials will be covered with rolled erosion control products when the material is expected to be left in place in excess of 10 days
 - Install temporary straw bale check dams (per OPSD 219.180) within 15 m downstream of new culvert construction
 - No equipment should be permitted to enter any natural areas beyond the silt fencing during construction;
 - Topsoil stockpiles should be sufficiently distant from watercourses to preclude sediment inputs due to erosion of stored soil materials;
 - If the sediment and erosion control measures are not functioning properly, no further work should occur until the sediment and/or erosion problem is addressed;
- Complete work in and around watercourses when the features are at their driest. All in-water work should be completed within MNR timing windows to protect local fish populations during their spawning and egg incubation periods. A typical construction timing window for warmwater streams in the Peterborough District is July 1st to March 31st.
- All materials and equipment used for the purpose of site preparation and Project construction should be operated and stored in a manner that prevents any deleterious substance (e.g., petroleum products, silt, etc.) from entering the water:
 - Any stockpiled materials should be stored and stabilized away from the water;
 - Refuelling and maintenance of construction equipment should occur in designated areas, a minimum of 100 m from a water body;
 - Spills should be reported to the MOE Spills Action Centre;
 - Any part of equipment entering the water should be free of fluid leaks and externally cleaned/degreased to prevent any deleterious substance from entering the water; and
 - Only clean material, free of fine particulate matter should be placed in the water.
- Revegetate all disturbed areas where construction is not expected for 30 days with a minimum 50 mm of topsoil and hydro-seeding or other stabilizing vegetation / erosion protection measures (per OPSS 804). If, given seasonal restriction or other revegetation

**AMHERST ISLAND WIND ENERGY PROJECT,
EROSION AND SEDIMENT CONTROL AND STORMWATER MANAGEMENT PLAN REPORT, PHASE 1**

Assessment of Potential Hydrologic Impacts and Mitigation (ESC)
October 17, 2016

limiting factors, the disturbed area should be stabilized against erosion impacts by non-vegetated means such as erosion control blankets.

The ESC measures shall be maintained in good repair during the entire construction period, and removed as contributing drainage areas are restored and stabilized. ESC measures shall not be removed until a qualified inspector determines that the measures are no longer required and the risk of surface water and environmental impacts from construction activities are negligible. In addition, the condition of erosion control works, their overall performance, and any repairs replacement or modifications to the installed item shall be noted in logbooks to be kept on-site.

3.4 EROSION AND SEDIMENTATION CONTROL MONITORING PLAN

In order to ensure the effectiveness of the various erosion and sediment control measures, a routine program should be implemented which includes the inspection of the erosion and sediment controls daily and after each significant rainfall event (10 mm), and immediate repair of any deficiencies. This program will consist of the following activities:

- Visual inspection of the ESC measures to ensure discharged flows are generally free of sediment and turbidity
- Inspection of vegetation protection and silt fencing to ensure that they are maintained in good repair
- Removal of construction debris that may accumulate
- Implementation of remedial measures including erosion stabilization, repair of damaged fencing and any other remediation, where required.

If the monitoring program outlined above indicates a persistent problem then the following process should be undertaken to determine appropriate mitigative measures:

- Analysis of the monitoring information and field visits as required, determine the cause of the problem, and develop a mitigation plan to address the issue.
- Convene a meeting with the appropriate review agencies to discuss the problem.
- Develop a consensus on a proposed plan of action to resolve the problem in consultation with agency staff.
- Implement additional mitigation measures and monitor the results.

**AMHERST ISLAND WIND ENERGY PROJECT,
EROSION AND SEDIMENT CONTROL AND STORMWATER MANAGEMENT PLAN REPORT, PHASE 1**

Assessment of Potential Hydrologic Impacts and Mitigation (ESC)
October 17, 2016

3.5 LONG TERM EROSION AND SEDIMENT CONTROL

Per the *Construction Plan Report*, upon the completion of backfilling and the subsequent disposition of excess soil elsewhere within the properties by the property owners, replanting with native vegetation will be undertaken in areas where active agricultural is not anticipated.

One year after construction a survey will be undertaken to ensure that long-term erosion control measures have been effective. This will include an inspection of drainage facilities associated with the Project construction (e.g., culverts) for structural integrity and any excessive amount of silt collection. Seeded or replanted areas will be inspected to ensure that revegetation measures were successful and reseeding or replanting will occur where necessary.

If erosion control measures are found to be less than fully effective during this survey, reseeding or replanting of problem areas will take place. Should there be residual effects noted during post-construction monitoring, advice on contingency measures will be sought out and applied.

**AMHERST ISLAND WIND ENERGY PROJECT,
EROSION AND SEDIMENT CONTROL AND STORMWATER MANAGEMENT PLAN REPORT, PHASE 1**

Conclusions
October 17, 2016

4.0 CONCLUSIONS

It is concluded that both the relative lack of change in impervious coverage associated with the proposed development and the resultant total impervious coverage within the local drainage catchments are sufficiently limited as to not impact the pre-development hydrologic characteristics of the area during construction or long-term operation of the facility. There should be negligible change/impact on the quality and/or quantity of surface water runoff and/or groundwater recharge and, therefore, no requirement for the implementation of formal stormwater quality or quantity controls.

While the site assessment yields a “high” erosion potential classification, a number of factors combine to limit the potential for impact on the receiving systems. Specifically the relatively small area proposed to be disturbed, the short-term nature of the disturbance prior to stabilization whether through granular placement or re-vegetation, and the existing land use of the surrounding area as agricultural operations all combine to create a condition where a “standard” approach to erosion and sediment control will suffice to minimize potential for off-site impacts. The proposed erosion and sediment control plan accompanied by a monitoring and maintenance program will be implemented to prevent migration of sediment to downstream features during the construction phase of the Project.

ATTACHMENTS



- Legend**
- Study Area
 - Point of Interest
 - Virtual Drainage Line
 - Surface Water Catchment Area
 - Project Components**
 - Turbine
 - Met Tower - Potential Location
 - Access Road
 - Collector Line
 - Submarine Cable Path
 - Laydown Area and Crane Pad (No Changes Proposed)
 - Operation and Maintenance Building (Potential Location)
 - Turbine Blade Tip
 - Substation (Potential Location)
 - Culvert Location
 - Point of Common Coupling
 - Mainland Cable Vault
 - Island Cable Vault
 - Aboveground Storage Tanks (Potential Location)
 - Constructible Area
 - Mainland Dock
 - Island Dock
 - Batch Plant (Potential Location)
 - Site Office (Potential Location)
 - Storage Shed
 - Transmission Lines**
 - Mainland Transmission Line
 - Island Transmission Line
 - Land Use**
 - Central Staging Area
 - Switching Station (Potential Location)
 - Existing Features**
 - Road
 - Unopened Road Allowance
 - Railway
 - Topographic Contour (metres AMSL)
 - Property Line

- Notes**
1. Coordinate System: NAD 1983 UTM Zone 18N
 2. Base features produced under license with the Ontario Ministry of Natural Resources © Queen's Printer for Ontario, 2016.
 3. Orthoimagery © Cataraqui Region Conservation Authority, 2016. Imagery taken in 2014.

October 2016
160960595

Client/Project
Windlectric Inc.
Amherst Island Wind Energy Project

Figure No.
1

Title
Points of Interest -
Drainage Area #4

\\C:\1220-102\01609\active\60960595\drawing\MXD\FRT\Drainage_Locations\160960595_ERR_Fig01_POI_Catchments_20160209.mxd
 Revised: 2016-10-04 By: pworsell

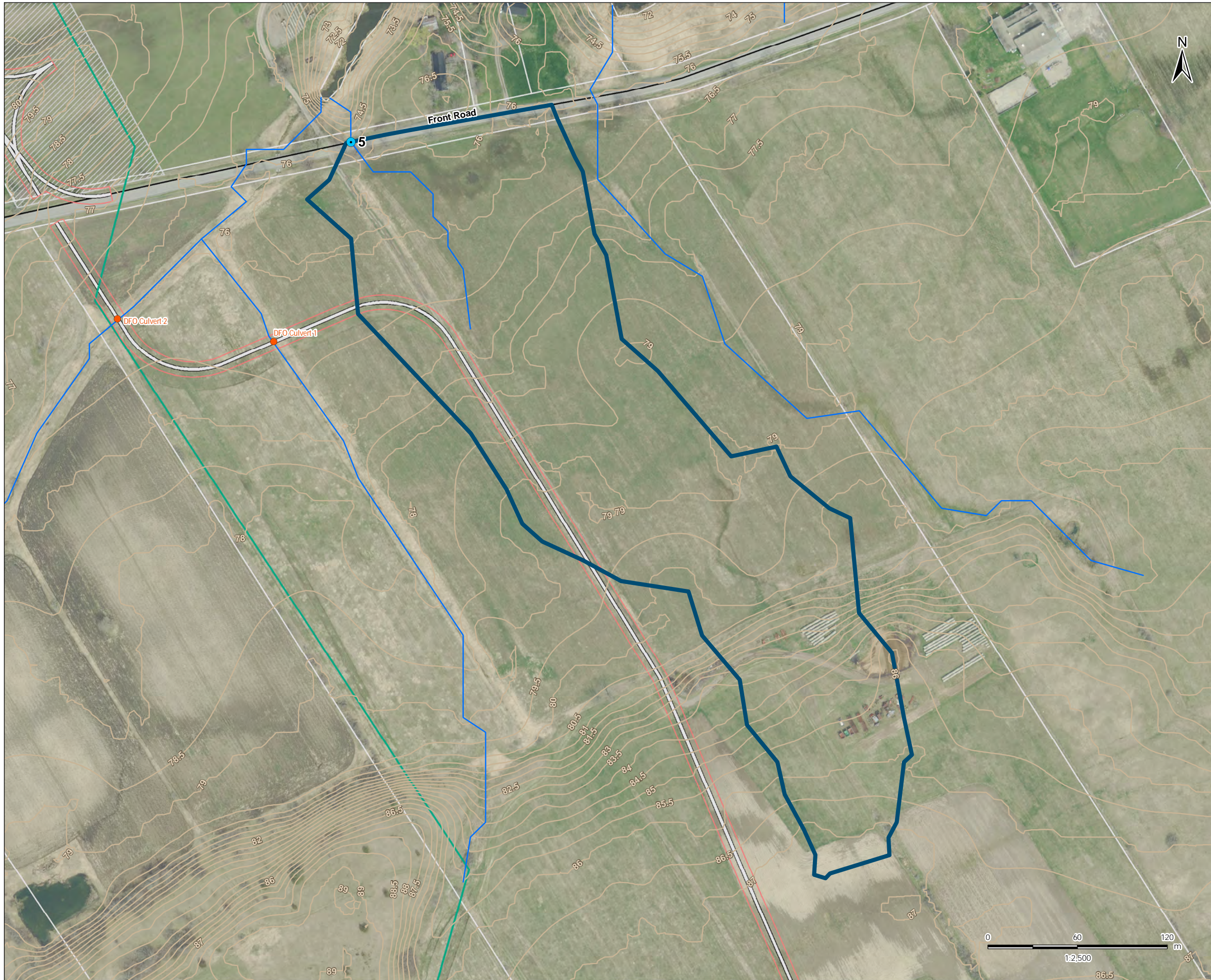

- Legend**
- Study Area
 - Point of Interest
 - Virtual Drainage Line
 - Surface Water Catchment Area
 - Project Components**
 - Turbine
 - Met Tower - Potential Location
 - Access Road
 - Collector Line
 - Submarine Cable Path
 - Laydown Area and Crane Pad (No Changes Proposed)
 - Operation and Maintenance Building (Potential Location)
 - Turbine Blade Tip
 - Substation (Potential Location)
 - Culvert Location
 - Point of Common Coupling
 - Mainland Cable Vault
 - Island Cable Vault
 - Aboveground Storage Tanks (Potential Location)
 - Constructible Area
 - Mainland Dock
 - Island Dock
 - Batch Plant (Potential Location)
 - Site Office (Potential Location)
 - Storage Shed
 - Transmission Lines**
 - Mainland Transmission Line
 - Island Transmission Line
 - Land Use**
 - Central Staging Area
 - Switching Station (Potential Location)
 - Existing Features**
 - Road
 - Unopened Road Allowance
 - Railway
 - Topographic Contour (metres AMSL)
 - Property Line

Notes

1. Coordinate System: NAD 1983 UTM Zone 18N
2. Base features produced under license with the Ontario Ministry of Natural Resources © Queen's Printer for Ontario, 2016.
3. Orthoimagery © Cataraqui Region Conservation Authority, 2016. Imagery taken in 2014.

October 2016
160960595

Client/Project
Windlectric Inc.
Amherst Island Wind Energy Project

Figure No.
1

Title
Points of Interest -
Drainage Area #5

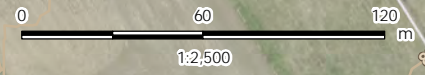

\\C01220-102-101609\active\60960595\drawing\MXD\Surface_Water_Report_Figures\160960595_SW_Fig01_POI_Catchments_20161003.mxd
 Revised: 2016-10-03 By: pwnorsell



- Legend**
- Study Area
 - Point of Interest
 - Virtual Drainage Line
 - Surface Water Catchment Area
 - Access Road
 - Constructible Area
 - Island Transmission Line
- Existing Features**
- Road
 - Unopened Road Allowance
 - Topographic Contour (metres AMSL)
 - Property Line

- Notes**
1. Coordinate System: NAD 1983 UTM Zone 18N
 2. Base features produced under license with the Ontario Ministry of Natural Resources © Queen's Printer for Ontario, 2016.
 3. Orthoimagery © Cataraqui Region Conservation Authority, 2016. Imagery taken in 2014.

September 2016
160960595

Client/Project
Windlectric Inc.
Amherst Island Wind Energy Project

Figure No.
1

Title
Drainage Area #15

\\Cd1220-102\01609\active\160960595\drawing\PDF\Surface_Water\Client_Requests\Island_Central_Staging_Area\160960595_SW_Fig01_Drainage_Area_15.mxd
 Revised: 2016-09-27 By: pworsell



Photo 1 Typical access road construction at a wind project



Photo 2 Typical access road construction at a wind project



PREPARED FOR:
Windlectric Inc.

SITE:
Amherst Island Wind Energy Project
Erosion and Sediment Control /
Stormwater Management Plan

TITLE
Photograph

PAGE
1 of 3



Photo 3 Typical access road construction at a wind project



Photo 4 Typical access road construction at a wind project



PREPARED FOR:
Windlectric Inc.

SITE:
Amherst Island Wind Energy Project
Erosion and Sediment Control /
Stormwater Management Plan

TITLE
Photograph

PAGE
2 of 3



Photo 5 Typical access road construction at a wind project



PREPARED FOR:
Windlectric Inc.

SITE:
Amherst Island Wind Energy Project
Erosion and Sediment Control /
Stormwater Management Plan

TITLE
Photograph

PAGE
3 of 3

Copyright Reserved

The contractor shall verify and be responsible for all dimensions. DO NOT scale the drawing - any errors or omissions shall be reported to Stantec without delay. The Copyrights to all designs and drawings are the property of Stantec. Reproduction or use for any purpose other than that authorized by Stantec is forbidden.

Consultants

Legend

- Direction of Surface Water Flow
- Equalization Culvert
- Silt Fence
- Straw Bale
- Virtual Drainage Line
- Topographic Contour (metres AMSL)
- Island Transmission Line
- Access Road
- Constructible Area
- Property Line
- Central Staging Area



NOTES:

CULVERT INSTALLATION

THESE WORKS SHALL INCLUDE, WITHOUT LIMITATION, THE DEWATERING, DIVERSION, AND/OR PUMPING OF DISCHARGE OF BOTH GROUND AND SURFACE WATER DURING INSTALLATION OF THE CULVERT CROSSING AND FINE GRADING. IT IS RECOMMENDED THAT ALL WORKS BE COMPLETED DURING DRY WEATHER CONDITIONS; IF AT ALL POSSIBLE.

THE TEMPORARY BYPASS REQUIRED TO INSTALL THE NEW CULVERT SHOULD ENSURE THAT WATER FLOW IS MAINTAINED DOWNSTREAM AT ALL TIMES FOR THOSE SYSTEMS THAT WOULD OTHERWISE BE FLOWING. IT IS THE CONTRACTOR'S DECISION TO UTILIZE A DAM AND PUMP METHODOLOGY OR CONSTRUCT A TEMPORARY BYPASS CHANNEL. PROPOSED METHODOLOGIES ARE SUBJECT TO THE APPROVAL OF THE CONSERVATION AUTHORITY.

IF A DAM AND PUMP METHODOLOGY IS ADOPTED, THE PUMP MUST BE OF SUFFICIENT SIZE TO CARRY THE TYPICAL FLOW OF THE FEATURE, AS WELL AS ELEVATED FLOWS DURING AND POST RAIN EVENTS. THIS MAY INCLUDE THE USE OF MULTIPLE PUMPS AS REQUIRED. THE DAM SHOULD BE STABLE AND OF SUFFICIENT HEIGHT TO IMPEDE STREAM FLOW WITHOUT OVER-TOPPING. THE DISCHARGE LOCATION OF THE DAM AND PUMP DIVERSION SHOULD ALLOW FOR CONTROLLED RELEASE OF WATER BACK INTO THE MUNICIPAL DRAIN AND BE MAINTAINED WITHOUT CAUSING SCOUR OR EROSION TO THE CHANNEL OR BANKS. AN MOE-ISSUED PERMIT TO TAKE WATER WOULD BE REQUIRED FOR DAM AND PUMP DIVERSIONS INVOLVING DAILY VOLUMES OF GREATER THAN 50,000 LITRES.

FISH STRANDED WITHIN THE WORK AREA MUST BE REMOVED AND TRANSFERRED DOWNSTREAM OR UPSTREAM OF THE WORK AREA.

PUMPS MUST OPERATE CONTINUOUSLY FOR THE DURATION OF THE CULVERT INSTALLATION AND THEREFORE FREQUENT AND NIGHTLY INSPECTIONS WILL BE REQUIRED.

WATER WITHIN THE WORK AREA IS TO BE PUMPED AND DISCHARGED WELL AWAY FROM THE DRAIN AND THROUGH A SEDIMENT TRAP OR SUFFICIENT VEGETATION TO ALLOW FOR ADEQUATE FILTRATION OF FINE PARTICULATE MATTER.

EQUIPMENT AND CONSTRUCTION MATERIAL SHALL BE STORED AWAY FROM THE WATER IN A MANNER THAT PREVENTS ANY DELETERIOUS SUBSTANCE FROM ENTERING THE WATER. REFUELING OF MACHINERY AND GENERATORS SHALL NOT BE CONDUCTED WITHIN THE VICINITY OF THE WATERCOURSE AND SHALL BE COMPLETED IN A CONTROLLED MANNER WITH ADEQUATE SPILL PROTECTION ON SITE.

THE AREA OF WATERCOURSE AND RIPARIAN ZONE THAT IS DISTURBED SHALL BE MINIMIZED TO THE EXTENT POSSIBLE.

EXISTING DITCH AND CULVERT DIMENSIONS AND DETAILS TO BE FIELD VERIFIED.

SEDIMENT AND EROSION CONTROL MEASURES SHALL BE IMPLEMENTED PRIOR TO WORK AND MAINTAINED DURING THE WORK PHASE AND UNTIL THE SITE HAS BEEN STABILIZED. ALL WORK WILL BE DONE IN ACCORDANCE WITH THE "EROSION AND SEDIMENT CONTROL GUIDELINE FOR URBAN CONSTRUCTION (2006)".

CULVERT CONSTRUCTION WILL OCCUR OUTSIDE OF ANY APPLICABLE FISHERIES TIMING RESTRICTION WINDOWS.

FOLLOWING INSTALLATION OF THE NEW CULVERT, THE CROSSING LOCATION WILL BE STABILIZED AND RESTORED TO ITS ORIGINAL CONDITIONS AND RESEEDED WITH SPECIES NATIVE TO ECOREGION 7E OR THE LOCAL AREA.

EROSION AND SEDIMENT CONTROL NOTES (SEE DETAILS THIS SHEET)

1. THE CONTRACTOR SHALL IMPLEMENT BEST MANAGEMENT PRACTICES TO PROVIDE PROTECTION OF THE AREA DRAINAGE SYSTEM DURING CONSTRUCTION ACTIVITIES. THIS INCLUDES LIMITING THE AMOUNT AND DURATION OF EXPOSED SOIL AND INSTALLING SILT FENCES AND OTHER SEDIMENT TRAPS/FILTERS SIMILAR TO THOSE ILLUSTRATED HEREIN.

2. EROSION AND SEDIMENT CONTROL WORKS SHALL BE INSTALLED AND IN WORKING CONDITION PRIOR TO COMMENCEMENT OF CONSTRUCTION RELATED ACTIVITIES.

3. SEDIMENT CONTROL MEASURES ADJACENT TO CONSTRUCTION AREAS MAY REQUIRE REMOVAL/RELOCATION IN ORDER TO COMPLETE SPECIFIC CONSTRUCTION ACTIVITIES. THE CONTRACTOR SHALL ENSURE THAT ADEQUATE SEDIMENT CONTROL MEASURES ARE IN PLACE AT ALL TIMES.

4. EROSION AND SEDIMENT CONTROL MEASURES ARE TO BE MAINTAINED AND IMPROVED UPON AS NECESSARY TO KEEP THEM EFFECTIVE AND MINIMIZE THE POTENTIAL FOR EROSION AND MIGRATION OF SEDIMENT TO THE DOWNSTREAM NATURAL ENVIRONMENT.

5. AT THE DISCRETION OF THE OWNER OR OWNER'S CONSULTANT, ADDITIONAL SILT CONTROL DEVICES SHALL BE INSTALLED AT DESIGNATED LOCATIONS.

6. SEDIMENT THAT IS ACCUMULATED BY THE TEMPORARY SEDIMENT AND EROSION CONTROL MEASURES SHALL BE REMOVED IN A MANNER THAT AVOIDS ESCAPE OF THE SEDIMENT TO THE DOWNSTREAM SIDE OF THE CONTROL MEASURE AND AVOIDS DAMAGE TO THE CONTROL MEASURE. ALL SEDIMENT SHALL BE REMOVED AND TOPSOIL WITH SEED TO BE ADDED IF NECESSARY.

7. STOCKPILED MATERIAL IS TO BE STORED AWAY FROM POTENTIAL RECEIVERS (E.G. WATERCOURSES), AND BE SURROUNDED BY EROSION CONTROL MEASURES WHERE MATERIAL IS TO BE LEFT IN PLACE IN EXCESS OF 10 DAYS OR PRIOR TO A RAIN EVENT, WHICHEVER OCCURS SOONER.

8. REMOVAL OF SEDIMENT CONTROL MEASURES AND COLLECTION OF ACCUMULATED SEDIMENT SHALL OCCUR FOLLOWING SUBSTANTIAL COMPLETION OF CONSTRUCTION (90%-100%) AND SITE STABILIZATION TO 90%.

9. IT IS THE RESPONSIBILITY OF THE CONTRACTOR TO MAINTAIN AND BOLSTER EROSION AND SEDIMENT CONTROL MEASURES AS NECESSARY TO KEEP THEM EFFECTIVE AND MINIMIZE THE POTENTIAL FOR EROSION.

10. IN ADDITION TO BEING RESPONSIBLE FOR ENSURING THAT THE PRESCRIBED MEASURES ARE INSTITUTED AND FUNCTIONING AS INTENDED THE CONTRACTOR IS ALSO RESPONSIBLE FOR IMPLEMENTING ANY INTERIM OR EMERGENCY MEASURES AS NECESSARY. TO ENSURE THAT NO SEDIMENT IS DISCHARGED TO THE NATURAL ENVIRONMENT, THE FOLLOWING EXTRA EQUIPMENT/MATERIALS ARE TO BE KEPT ON SITE AS A CONTINGENCY, IN CASE THE PROPOSED CONTROL MEASURES ARE BREACHED.

11. EROSION AND SEDIMENT CONTROL MONITORING RECORDS SHALL BE KEPT AND MADE AVAILABLE TO THE MINISTRY OF ENVIRONMENT AND CLIMATE CHANGE AND CATARAQUI REGION CONSERVATION AUTHORITY UPON REQUEST.

- SILT FENCE
- FILTER CLOTH
- PUMPS
- CLEAN RIP-RAP (FREE OF FINES) FOR ROCK CHECK DAMS
- SAND BAGS AND CLEAN (FREE OF FINES) GRAVEL

ANY ADDITIONAL MATERIAL DEEMED NECESSARY TO REPAIR/REMEDIATE PROPOSED MEASURES, OR TO ADEQUATELY DEAL WITH UNEXPECTED HIGH FLOWS

1. INSTALL ALL SILT FENCE AND PROTECTIVE FENCING AS SHOWN ON THE PLANS AND MAINTAIN DURING CONSTRUCTION.

AREA GRADING

PRIOR TO SITE WORKS

1. TEMPORARY TOPSOIL STOCKPILES ARE TO HAVE CONTINUOUS SILT FENCE PLACED IMMEDIATELY AROUND THE ENTIRE PERIMETER.

2. ROADWAYS AND LAY DOWN YARDS ARE TO BE PLACED ON NATIVE GROUND AFTER TOPSOIL HAS BEEN STRIPPED.

3. ALL TOPSOIL IS TO BE RE-SPREAD ON CONSTRUCTION IMPACTED AREAS AFTER FINAL GRADING IS COMPLETE TO A MINIMUM DEPTH OF 150mm.

4. SILT FENCE AND EROSION CONTROL STRUCTURES TO BE CHECKED DAILY AND AFTER EACH RAINFALL >10mm FOR UNDERMINING OR DETERIORATION OF THE FABRIC. SEDIMENT SHALL BE REMOVED WHEN THE LEVEL OF SEDIMENT DEPOSITION REACHES ONE THIRD OF THE WAY TO THE TOP OF THE BARRIER.

AFTER AREA GRADING

1. ALL AREAS WHERE ACTIVE CONSTRUCTION IS NOT EXPECTED FOR 2 WEEKS SHALL BE RE-SEDED WITH NATIVE PLANT SPECIES.

2. REMOVAL OF SEDIMENT CONTROL MEASURES AND COLLECTION OF ACCUMULATED SEDIMENT SHALL OCCUR FOLLOWING SUBSTANTIAL COMPLETION OF CONSTRUCTION (90%-100%) AND SITE STABILIZATION TO 90%.

SLOPE PROTECTION NOTES

1. EITHER ROLLED EROSION CONTROL PRODUCTS (RECP) OR MULCHMAX ULTRA AT 500 KG/HA ARE TO BE USED ON 3:1 SLOPES OR GREATER.

2. RECP PRODUCTS ARE TO BE BIODEGRADABLE. STRAW, COIR, WOOD EXCELSIOR ARE SAMPLE MATERIALS THAT CAN BE USED.

3. RECP PRODUCTS ARE TO BE INSTALLED PER MANUFACTURER SPECIFICATIONS. INSTALLATION TO BE INSPECTED AND REPAIRED AS NEEDED.

4. RECP ARE TO BE APPLIED AS SOON AS POSSIBLE FOLLOWING GRADING AND SEEDING OF SUBJECT AREAS.

5. SURFACES ARE TO BE SMOOTH AND FREE OF STONES AND DEBRIS OR OTHER WEED CLUMPS PRIOR TO RECP PRODUCTS BEING INSTALLED.

6. CONTRACTOR TO ENSURE THAT BILLING/GULLYLING IS RECTIFIED PRIOR TO RECP OR MULCHMAX ULTRA INSTALLATION. CONTRACTOR TO MONITOR RUNOFF UNDER THE RECP FOLLOWING INSTALLATION.

7. CONTRACTOR TO ENSURE THAT RECP IS SECURED AT THE TOP OF THE SLOPE IN A TRENCH AND OVERLAP (SIDE TO SIDE AND BOTTOM TO TOP)

8. CONTRACTOR TO INSPECT THE SITE DAILY OR AFTER SIGNIFICANT RAINFALL EVENTS (10mm) AND IDENTIFY AREAS OF EROSION OR POTENTIAL EROSION. BEST MANAGEMENT PRACTICES ARE TO BE USED TO CONTROL THE EROSION. METHODS OF CONTROL MAY INCLUDE THE USE OF EROSION CONTROL BLANKETS C/W SEEDING, HYDRAULIC MULCH OR STRAW MULCH, OR SOIL BINDER. SOILS ARE TO BE STABILIZED AS SOON AS AREAS ARE IDENTIFIED TO PREVENT FURTHER EROSION.

SILT FENCE NOTES (SEE DETAIL OPSD 219.110)

1. STAKES ARE TO BE INSTALLED ON THE DOWNSTREAM SIDE OF THE BARRIER

2. CONTRACTOR TO MONITOR SILT FENCE FOR UV DEGRADATION

3. SILT FENCE IS TO BE CLEANED OUT ONCE SEDIMENT REACHES MAXIMUM 1/3 OF THE FENCE HEIGHT

HYDRAULIC MULCH NOTES

1. COORDINATE/CONSULT WITH OWNER PRIOR TO UTILIZING ANY HYDRAULIC MULCH. TIMELINES AND SEEDING METHODS NEED TO BE CAREFULLY CONSIDERED PRIOR TO IMPLEMENTATION.

2. ENSURE THAT A TACKIFIER IS USED TO KEEP PRODUCT IN PLACE

3. APPLY SEED MIX PRIOR TO MULCH WITH TACKIFIER

4. HYDRAULIC MULCH IS TO BE APPLIED AS SOON AS GRADING AND SEEDING WORK IS COMPLETE TO ENSURE STABILIZATION OF SOILS.

5. RE-APPLY HYDRAULIC MULCH IF THE SUBJECT AREA IS DAMAGED OR ERODED BY WIND OR WATER

GENERAL

1. EQUIPMENT AND CONSTRUCTION MATERIAL SHALL BE STORED AWAY FROM THE WATER IN A MANNER THAT PREVENTS ANY DELETERIOUS SUBSTANCE FROM ENTERING THE WATER. REFUELING OF MACHINERY AND GENERATORS SHALL NOT BE CONDUCTED WITHIN 30 m OF A WATERCOURSE AND SHALL BE COMPLETED IN A CONTROLLED MANNER WITH ADEQUATE SPILL PROTECTION ON SITE.

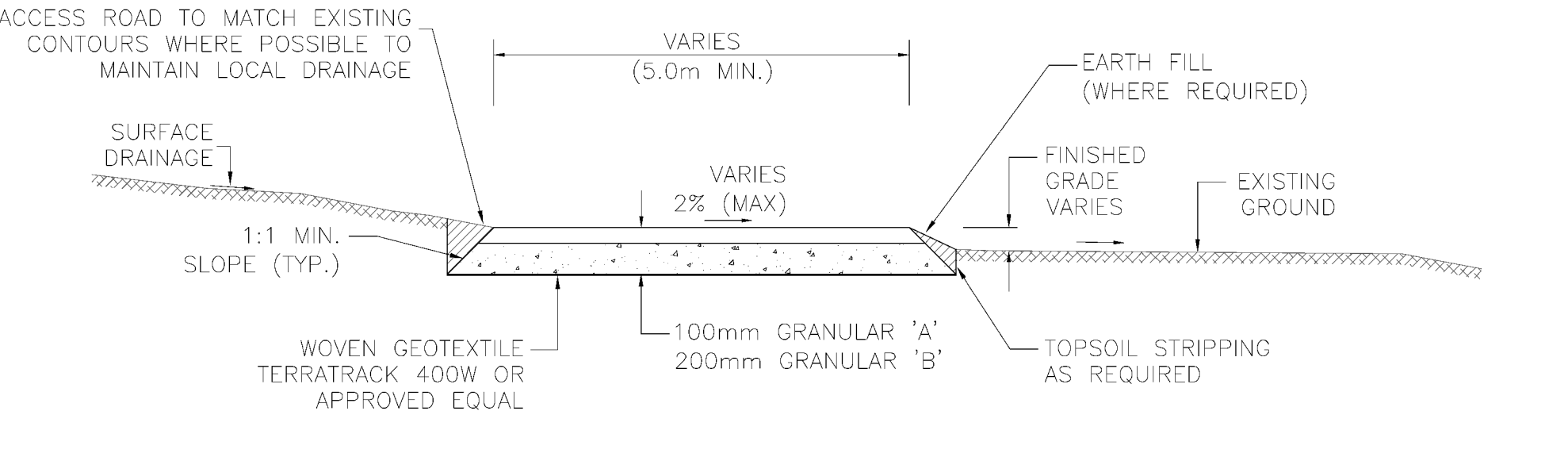
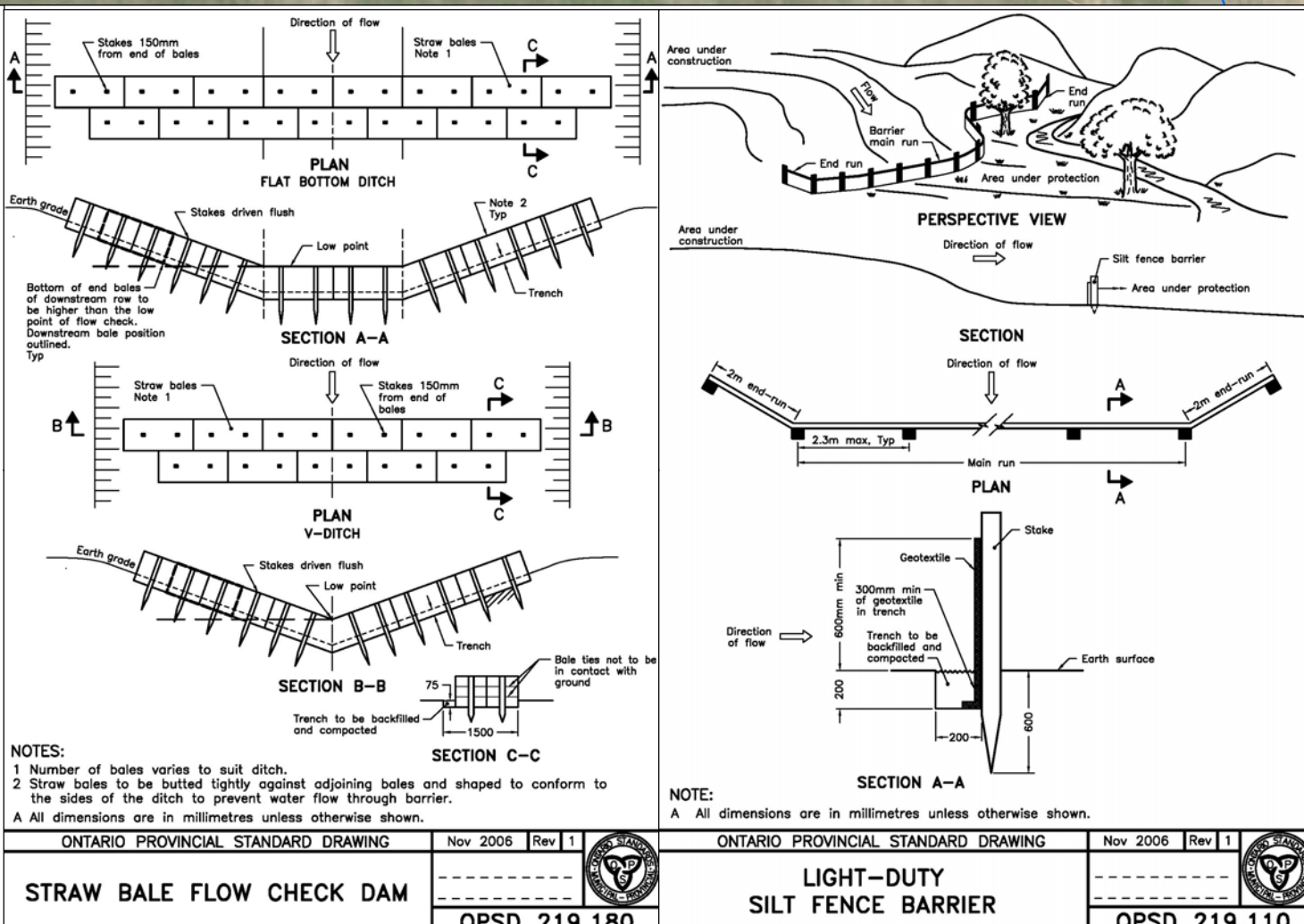
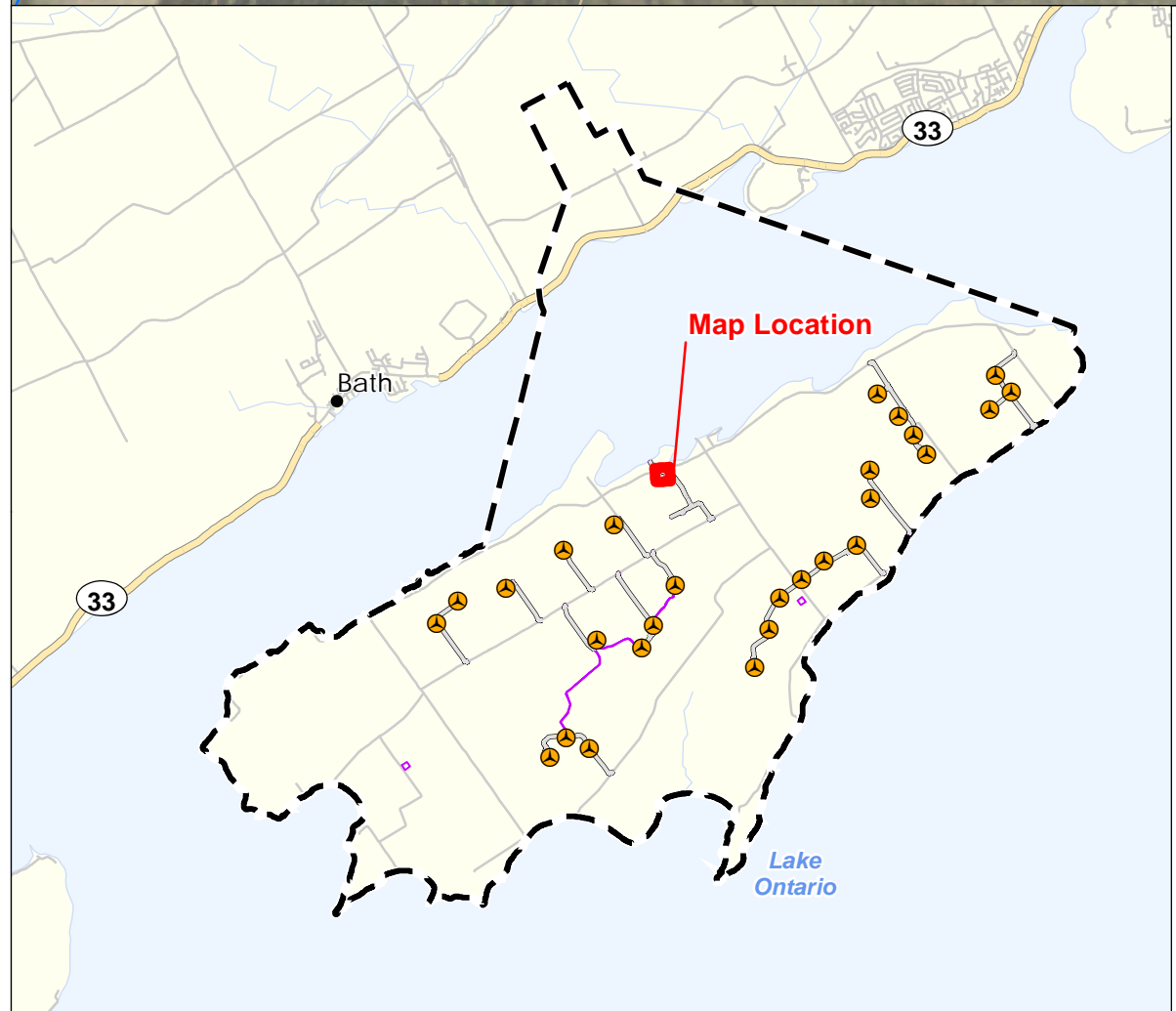

TYPICAL ACCESS ROAD - CUT CONDITION
N.T.S

Notes
1. Coordinate System: NAD 1983 UTM Zone 18N
2. Base features produced under license with the Ontario Ministry of Natural Resources and Forestry @ Queen's Printer for Ontario, 2016.
3. Orthorectification © Cataraqui Region Conservation Authority, 2016. Imagery taken in 2014.

Notes

1. TOPOGRAPHIC SURVEY COMPLETED BY MANTOSH PERRY CONSULTING ENGINEERS DATED 2015 (UTM ZONE 18 NAD83 (CSRS)1987.0)
2. BENCHMARK IS AS LABELED ON THE GRADING AND SITE PLANS
3. GEOTECHNICAL INFORMATION PROVIDED BY MACK, DATED OCTOBER, 2012.
4. THIS DRAWING IS TO BE READ IN CONJUNCTION WITH ALL OTHER DRAWINGS IN THIS SET PREPARED BY STANTEC CONSULTING LTD.
5. THE CONTRACTOR MUST CHECK AND VERIFY DIMENSIONS, OBTAIN ALL UTILITY LOCATES AND OBTAIN ALL REQUIRED PERMITS/LICENSES AND VERIFY ELEVATIONS OF EXISTING SERVICES BEFORE PROCEEDING WITH ANY WORK.
6. ALL CONSTRUCTION WORK SHALL BE CARRIED OUT IN ACCORDANCE WITH THE REQUIREMENTS OF THE OCCUPATIONAL HEALTH AND SAFETY ACT AND REGULATIONS FOR CONSTRUCTION PROJECTS (LATEST EDITION).
7. IF, FOR UNFORESEEN REASONS, THE OWNER AND/OR HIS/HER REPRESENTATIVE MUST ENCROACH ONTO PRIVATE LANDS TO UNDERTAKE ANY WORKS, HE/SHE MUST OBTAIN WRITTEN PERMISSION FROM THE ADJACENT PROPERTY OWNERS PRIOR TO ENTERING UPON THE PRIVATE PROPERTY TO PERFORM ANY WORKS. COPIES OF THESE LETTERS OF CONSENT MUST BE SUBMITTED TO STANTEC. PRIOR TO ANY WORK BEING PERFORMED. FAILURE TO COMPLY WITH THE ABOVE IS AT THE PROPERTY OWNERS OWN RISK. ENCROACHMENT ON NON-PARTICIPATING PROPERTIES IS STRICTLY PROHIBITED.
8. THE CONTRACTOR IS RESPONSIBLE FOR RESTORATION OF ALL DAMAGED AND/OR DISTURBED PROPERTY WITHIN THE MUNICIPAL RIGHT-OF-WAY TO THE CURRENT MUNICIPAL STANDARDS.
9. THE CONTRACTOR IS TO BE RESPONSIBLE FOR ALL DRAINAGE AND MEASURES TO CONTROL WATER. THE SITE IS TO BE FINE GRADED/LEVELLED LEAVING THE SITE IN A NEAT APPEARANCE SUCH THAT POSITIVE DRAINAGE IS ACHIEVED EVERYWHERE PRIOR TO THE INSTALLATION OF SOLAR PANELS.
10. CONSTRUCTION TURNING POINTS LIMITS IDENTIFY AREAS WHERE ADDITIONAL ROAD WIDTH IS REQUIRED TO ALLOW FOR ADEQUATE CLEARANCE FOR CONSTRUCTION VEHICLES.
11. CULVERTS ARE TO BE INSTALLED AS PER OPSD 802.010.
12. ALL AREAS WITHIN THE PROPOSED WORKS ARE TO BE RE-VEGETATED USING NATIVE TOPSOIL AND SEED, MIX AND APPLICATION RATE/METHOD TO BE APPROVED BY OWNER PRIOR TO IMPLEMENTATION.
13. CLEARING AND GRUBBING AND REMOVALS TO BE COMPLETED IN ACCORDANCE WITH OPSD 201.
14. TEMPORARY EROSION CONTROL TO BE COMPLETED IN ACCORDANCE WITH OPSD 577.
15. GRADING TO BE COMPLETED IN ACCORDANCE WITH OPSD 206. GRANULAR MATERIAL TO BE USED IN ACCORDANCE WITH OPSD 1010.
16. CULVERT TO BE CONSTRUCTED IN ACCORDANCE WITH OPSD 421.

Legend

- EXISTING OVERLAND FLOW/DITCH DIRECTION
- PROPOSED DITCH FLOW
- EXISTING GROUND CONTOURS (AS PER NOTE 4 ABOVE)
- EXISTING GROUND CONTOURS (FROM LIDAR MAPPING)
- TEMPORARY OVERBUILD AREA
- HEAVY DUTY SILT FENCE
- STRAW BALE FLOW CHECK DAM (OPSD 219.180)
- ROCK FLOW CHECK DAM (OPSD 219.210)
- APPROXIMATE LOCATION OF EXISTING VEGETATED STRIP

B. REVISED PER MOECC COMMENTS	JBM	DKS	16.10.27
A. ISSUED FOR REVIEW	JBM	DKS	16.10.04
Revision	By	Appd.	YY.MM.DD

File Name: 133560100C-ST.dwg	KDB	DKS	KDB	16.09.21
Permit-Seal	Dwn.	Chkd.	Dgn.	YY.MM.DD

PRELIMINARY
NOT FOR CONSTRUCTION

Client/Project



AMHERST ISLAND WIND PROJECT
75MW WIND FARM
Amherst Island, Loyalist Township, Ontario

Title

ISLAND DOCK STOCKPILE LOCATIONS
GRADING AND SEDIMENT AND EROSION
CONTROL PLAN

Project No. 133560100	Scale 1:500	Sheet 0 5 15 25m
Drawing No.	Sheet	Revision

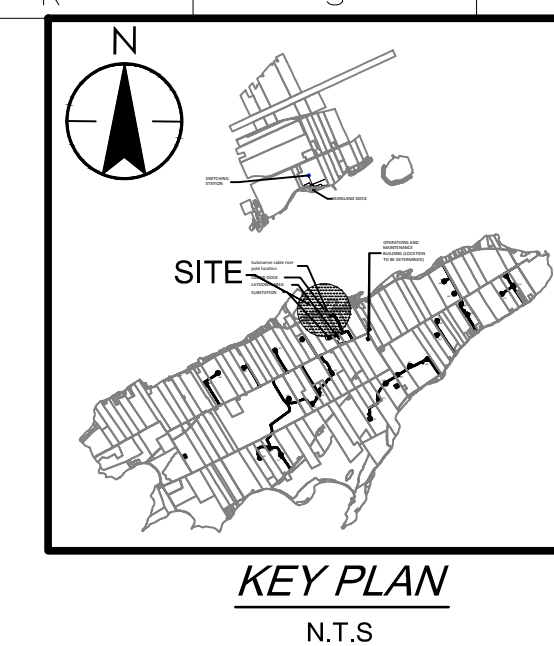

EROSION AND SEDIMENT CONTROL NOTES:
(SEE DETAILS THIS SHEET)

1. THE CONTRACTOR SHALL IMPLEMENT BEST MANAGEMENT PRACTICES TO PROVIDE FOR PROTECTION OF THE AREA DRAINAGE SYSTEM DURING CONSTRUCTION ACTIVITIES. THIS INCLUDES LIMITING THE AMOUNT AND DURATION OF EXPOSED SOIL AND INSTALLING SILT FENCES AND OTHER SEDIMENT TRAPS/FILTERS SIMILAR TO THOSE ILLUSTRATED HEREIN.
2. EROSION AND SEDIMENT CONTROL WORKS SHALL BE INSTALLED AND IN WORKING CONDITION PRIOR TO COMMENCEMENT OF CONSTRUCTION RELATED ACTIVITIES.
3. SEDIMENT CONTROL MEASURES ADJACENT TO CONSTRUCTION AREAS MAY REQUIRE REMOVAL / RELOCATION IN ORDER TO COMPLETE SPECIFIC CONSTRUCTION ACTIVITIES. THE CONTRACTOR SHALL ENSURE THAT ADEQUATE SEDIMENT CONTROL MEASURES ARE IN PLACE AT ALL TIMES.
4. EROSION AND SEDIMENT CONTROL MEASURES ARE TO BE MAINTAINED AND IMPROVED AS NECESSARY TO KEEP THEM EFFECTIVE AND MINIMIZE THE POTENTIAL FOR EROSION AND MIGRATION OF SEDIMENT TO THE DOWNSTREAM NATURAL ENVIRONMENT.
5. AT THE DISCRETION OF THE OWNER OR OWNER'S CONSULTANT, ADDITIONAL SILT CONTROL DEVICES SHALL BE INSTALLED AT DESIGNATED LOCATIONS.
6. SEDIMENT THAT IS ACCUMULATED BY THE TEMPORARY SEDIMENT AND EROSION CONTROL MEASURES SHALL BE REMOVED IN A MANNER THAT AVOIDS ESCAPE OF THE SEDIMENT TO THE DOWNSTREAM SIDE OF THE CONTROL MEASURE AND AVOIDS DAMAGE TO THE CONTROL MEASURE. ALL SEDIMENT SHALL BE REMOVED AND TOPSOIL WITH SEED TO BE ADDED IF NECESSARY.

7. SILT FENCE AND EROSION CONTROL STRUCTURES TO BE CHECKED DAILY AND AFTER EACH RAINFALL > 10mm FOR UNDERMINING OR DETERIORATION OF THE FABRIC. SEDIMENT SHALL BE REMOVED WHEN THE LEVEL OF SEDIMENT DEPOSITION REACHES ONE THIRD OF THE WAY TO THE TOP OF THE BARRIER.
8. ALL AREAS WHERE ACTIVE CONSTRUCTION IS NOT EXPECTED IS NOT EXPECTED FOR 2 WEEKS SHALL BE STABILIZED THROUGH SEEDING WITH NATIVE PLANT SPECIES AND APPLICATION OF HYDRAULIC MULCH.
9. STOCKPILED MATERIAL IS TO BE STORED AWAY FROM POTENTIAL RECEIVERS (E.G. WATERCOURSES), AND LOCATED AT LEAST 6m FROM THE BOUNDARY OF THE LAYDOWN AREA. WHERE STOCKPILED MATERIAL IS TO BE LEFT IN PLACE UNDISTURBED IN EXCESS OF 2 WEEKS OR PRIOR TO A RAIN EVENT (WHICHEVER OCCURS SOONER), THE STOCKPILE SHALL BE COVERED WITH A ROLLED EROSION CONTROL PRODUCT (RECP).
10. IT IS THE RESPONSIBILITY OF THE CONTRACTOR TO MAINTAIN AND BOLSTER EROSION AND SEDIMENT CONTROL MEASURES AS NECESSARY TO KEEP THEM EFFECTIVE AND MINIMIZE THE POTENTIAL FOR EROSION.
11. IN ADDITION TO BEING RESPONSIBLE FOR ENSURING THAT THE PRESCRIBED MEASURES ARE INSTITUTED AND FUNCTIONING AS INTENDED, THE CONTRACTOR IS ALSO RESPONSIBLE FOR IMPLEMENTING ANY INTERIM OR EMERGENCY MEASURES AS NECESSARY, TO ENSURE THAT NO SEDIMENT IS DISCHARGED TO THE NATURAL ENVIRONMENT. THE FOLLOWING EXTRA EQUIPMENT/MATERIALS ARE TO BE KEPT ON SITE AS A CONTINGENCY, IN CASE THE PROPOSED CONTROL MEASURES ARE BREACHED.
 - SILT FENCE
 - FILTER CLOTH
 - PUMPS
 - CLEAN RIP-RAP (FREE OF FINES) FOR ROCK CHECK DAMS
 - SAND BAGS
 - ANY ADDITIONAL MATERIAL DEEMED NECESSARY TO REPAIR/ CONSTRUCT PROPOSED MEASURES OR TO ADEQUATELY DEAL WITH UNEXPECTED HIGH FLOWS

CULVERT NOTES:

1. CULVERT SLOPE TO MATCH EXISTING DITCH GRADE UNLESS OTHERWISE NOTED.
2. CULVERT TO BE EMBEDDED 10% OF PIPE DIAMETER BELOW DITCH INVERT.
3. CULVERTS TO BE CORRUGATED STEEL PIPE (CSP). PIPE MATERIAL TO BE GALVANIZED STEEL AND HAVE A 68mm x 13mm CORRUGATION WITH 1.6mm METAL THICKNESS.
4. PIPE TO BE INSTALLED IN ACCORDANCE WITH OPSD 802.010.
5. CULVERT ELEVATIONS ARE APPROXIMATE AND ARE TO BE FINALIZED IN THE FIELD.

SILT FENCE NOTES (SEE DETAIL OPSD 219.110):

1. STAKES ARE TO BE INSTALLED ON THE DOWNSTREAM SIDE OF THE BARRIER.
2. CONTRACTOR TO MONITOR SILT FENCE FOR UV DEGRADATION.
3. SILT FENCE IS TO BE CLEANED OUT ONCE SEDIMENT REACHES MAXIMUM 1/3 OF THE FENCE HEIGHT.

HYDRAULIC MULCH NOTES:

1. COORDINATE/CONSULT WITH OWNER PRIOR TO UTILIZING ANY HYDRAULIC MULCH. TIMELINES AND SEEDING METHODS NEED TO BE CAREFULLY CONSIDERED PRIOR TO IMPLEMENTATION.
2. ENSURE THAT A TACKIFIER IS USED TO KEEP PRODUCT IN PLACE.
3. APPLY SEED MIX PRIOR TO MULCH WITH TACKIFIER.
4. HYDRAULIC MULCH IS TO BE APPLIED AS SOON AS GRADING AND SEEDING WORK IS COMPLETE TO ENSURE STABILIZATION OF SOILS.
5. RE-APPLY HYDRAULIC MULCH IF THE SUBJECT AREA IS DAMAGED OR ERODED BY WIND OR WATER. SURFACE COVERAGE MUST BE AT LEAST 80% AT ALL TIMES.

ROLLED EROSION CONTROL PRODUCT (RECP) NOTES:

1. RECP SHALL CONSIST OF STRAW, STRAW-COCOON, OR COCONUT FIBER WHICH ARE HELD IN PLACE BY NETTING SEWN ON BOTH SIDES OF THE MATERIAL.
2. RECP MUST BE SECURED ON STOCK PILE BY STAPLING AT THE BOTTOM OF THE SLOPE AND UPHILL TRENCHES ON THE STOCKPILE/SLOPED SURFACE.

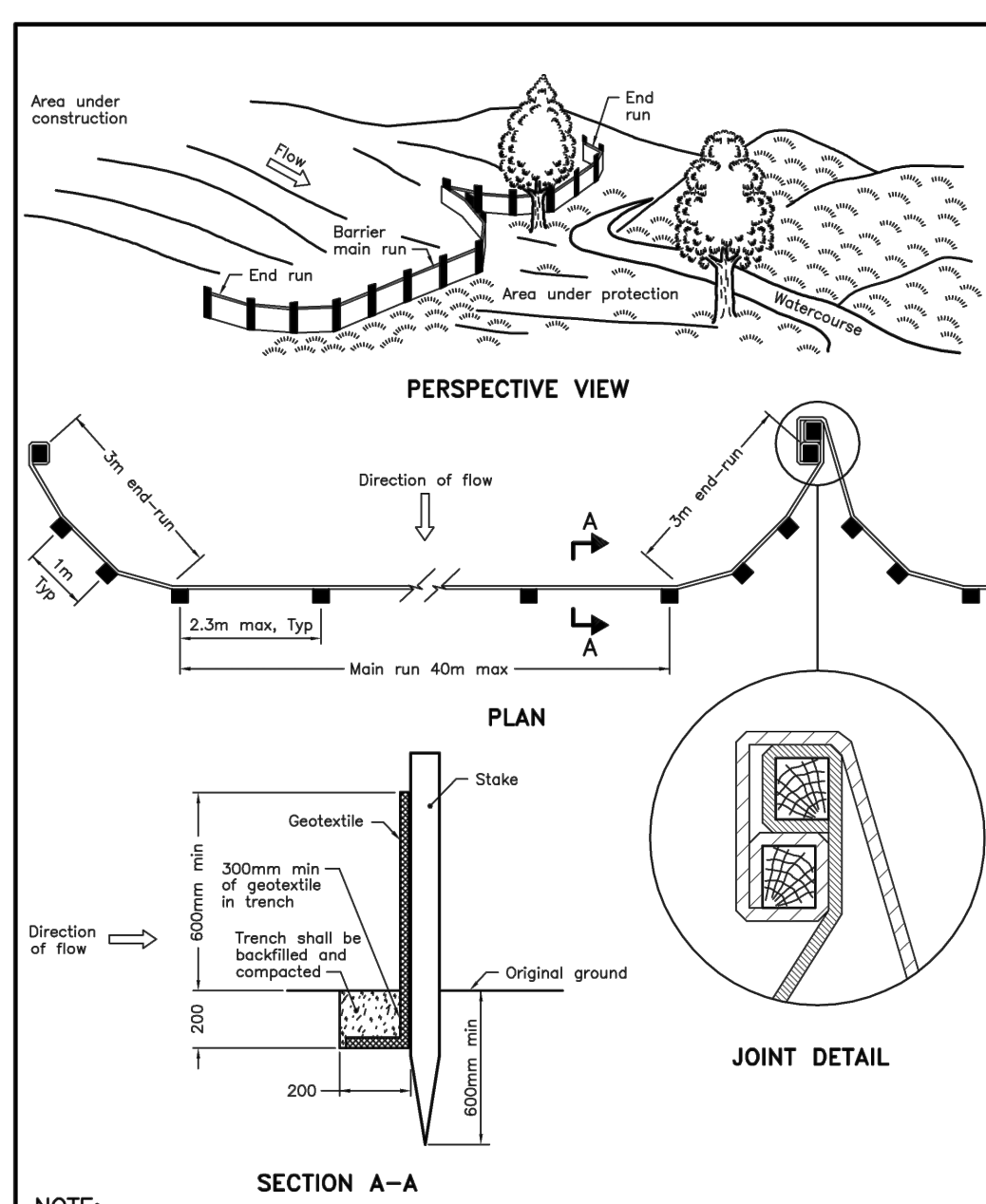

NOTE:
A All dimensions are in millimetres unless otherwise shown.

ONTARIO PROVINCIAL STANDARD DRAWING	Nov 2015	Rev 2
LIGHT-DUTY SILT FENCE BARRIER	OPSD 219.110	

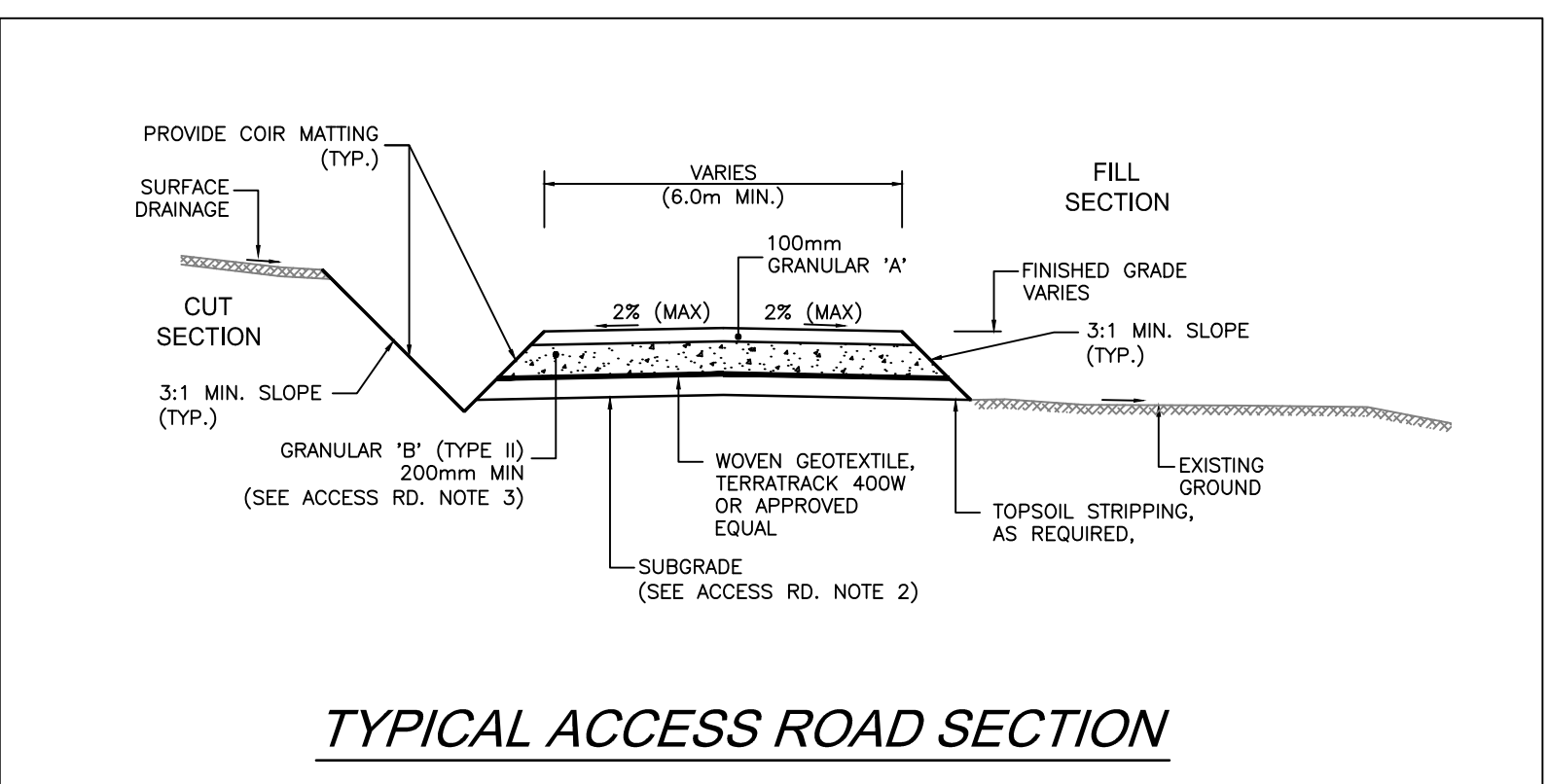
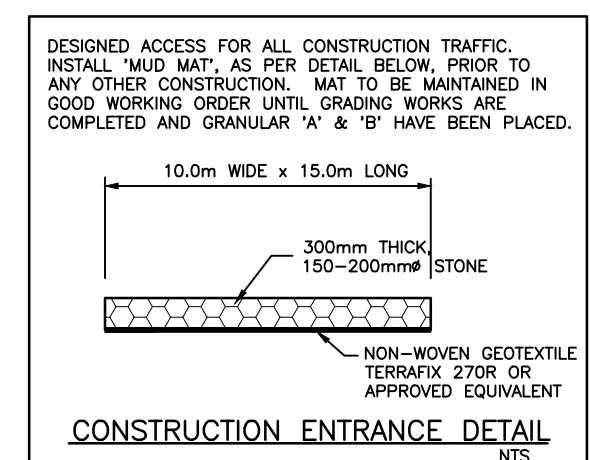
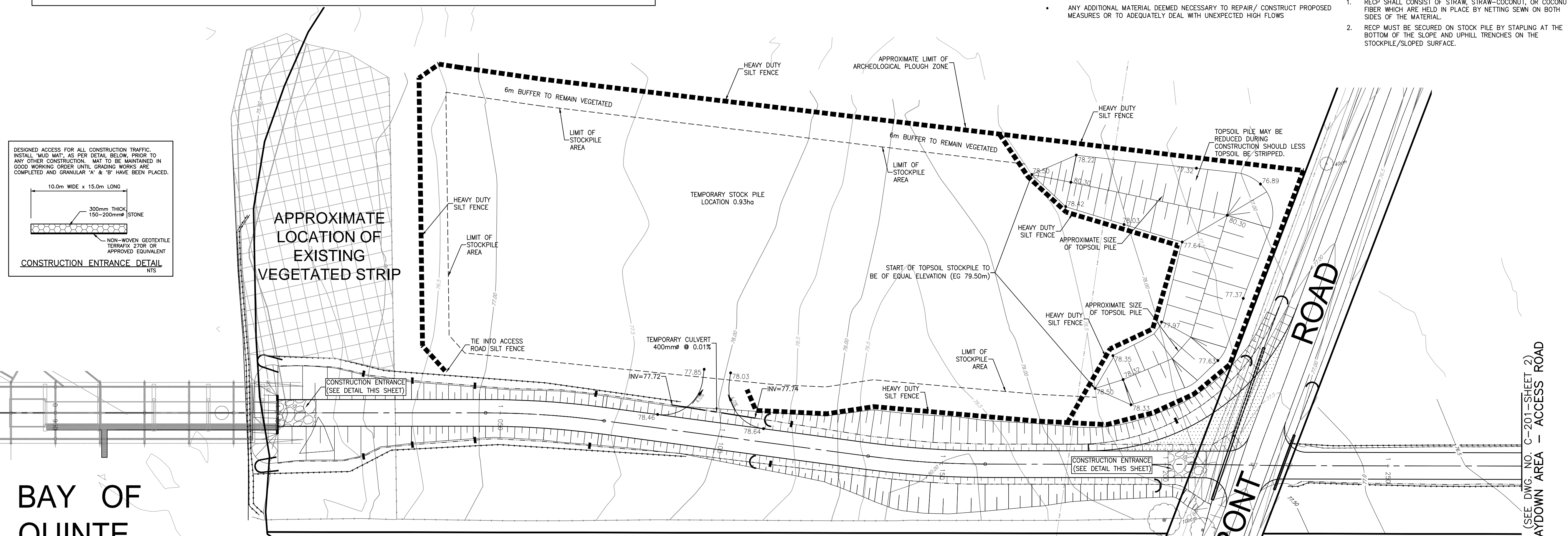
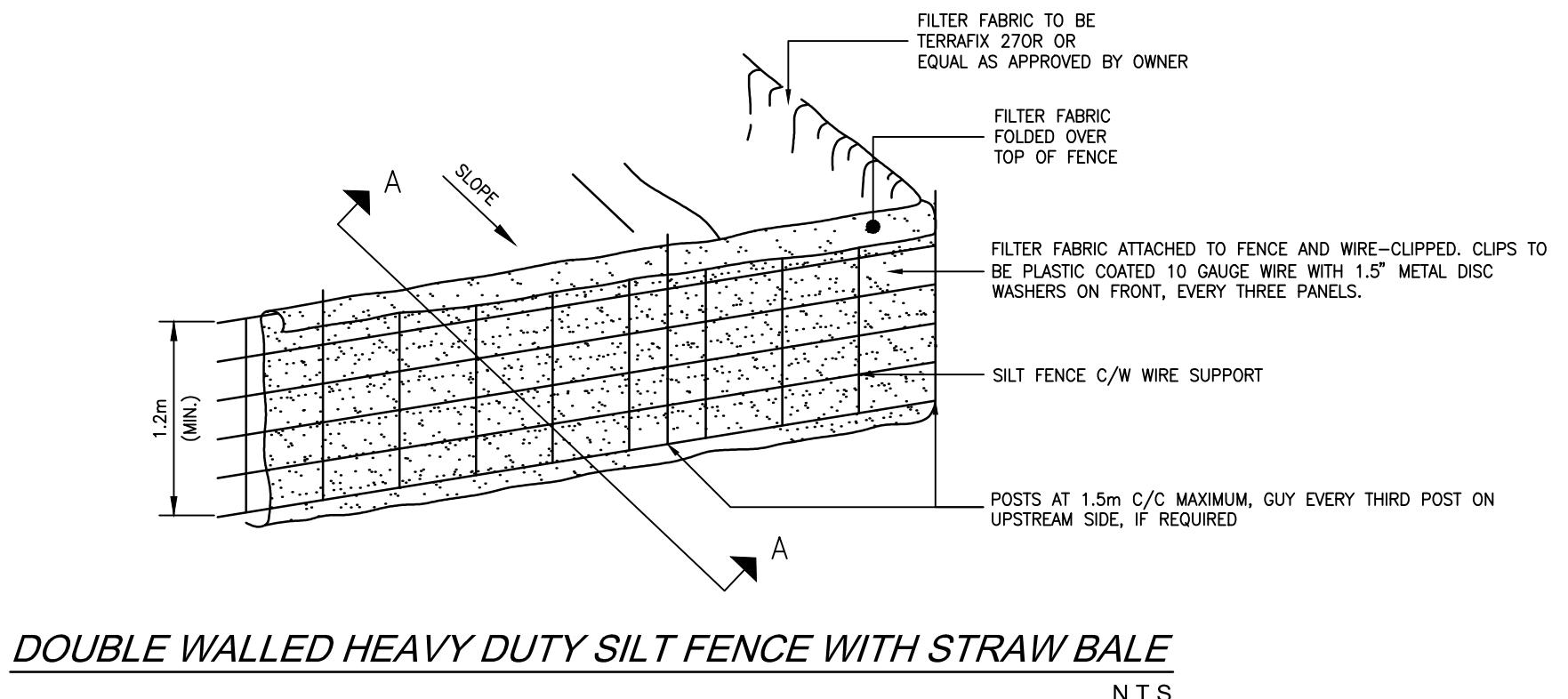
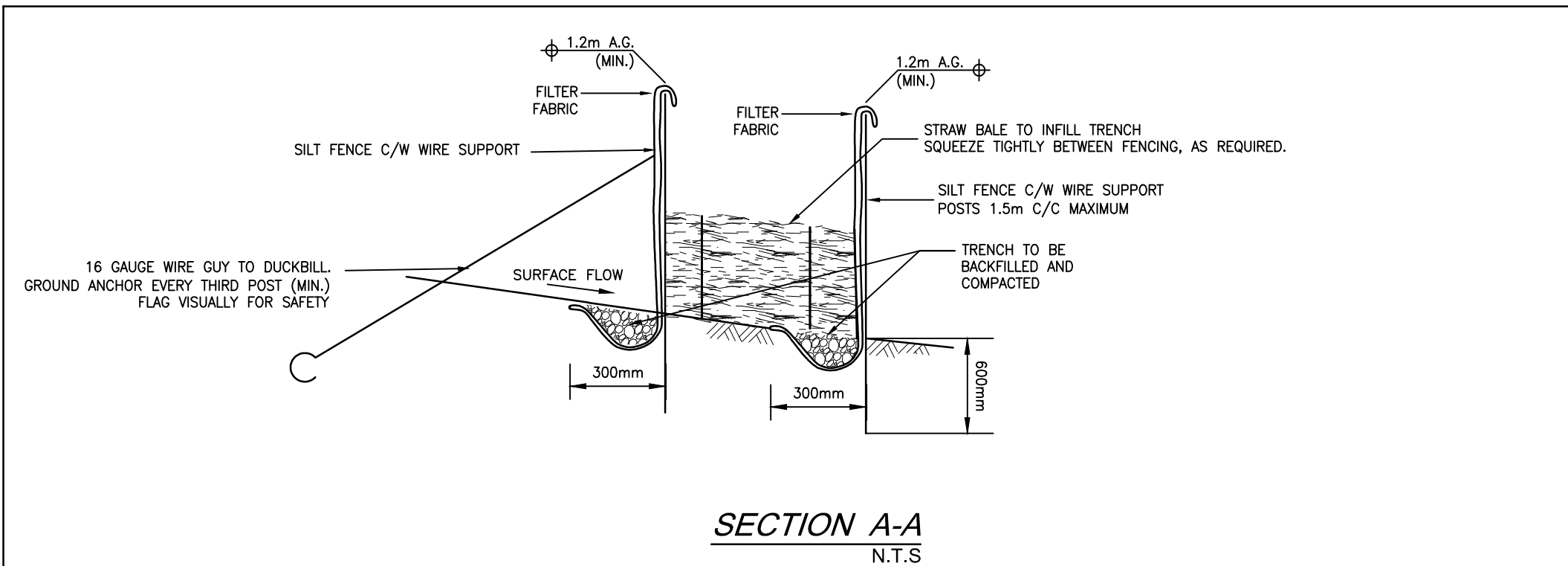

ISLAND DOCK ACCESS ROAD

NOTE: REFER TO DRAWING C-201 SHEET 1 OF 5 FOR ACCESS ROAD DESIGN

*****For PHCL and Windlectric Use Only*****

Review and/or accepted does not constitute approval of design details, calculations or methods. It is the responsibility of the consultant to ensure all information contained within the drawings are in full compliance with contractual obligations

Reviewed - Accepted and no comments

Reviewed - Incorporate comments and resubmit

Reviewed - Not accepted

Reviewed By	Date (dd-mmm-yyyy)
Project Manager - PHCL	Date (dd-mmm-yyyy)
Project Manager - Windlectric	Date (dd-mmm-yyyy)
Owner: Windlectric Inc.	